



RD102

**DANA 35, 27 SPLINE,
3.54 & UP**

**AIR OPERATED
LOCKING DIFFERENTIAL
INSTALLATION GUIDE**

No liability is assumed for damages resulting in the use of the information contained herein.
ARB Air Locker Air Operated Locking Differentials and Air Locker are trademarks of ARB Corporation Limited.
Other product names used herein are for identification purposes only and may be trademarks of their respective owners.

ARB 4x4 ACCESSORIES

Corporate Head Office

**42-44 Garden St
Kilsyth, Victoria
AUSTRALIA
3137**

Tel: +61 (3) 9761 6622

Fax: +61 (3) 9761 6807

Australian enquiries

North Central and South American enquiries

Other international enquiries

sales@arb.com.au

sales@arbusa.com

exports@arb.com.au

www.arb.com.au

Table of Contents:

1	Introduction	3
1.1	Pre-Installation Preparation	3
1.2	Tool-Kit Recommendations	4
1.3	Assembly Type Identification	5
2	Removing the Existing Differential	6
2.1	Vehicle Support	6
2.2	Differential Fluid Drain	6
2.3	Removing the Axles	7
2.4	Marking the Bearing Caps	8
2.5	Checking the Current Backlash Amount	9
2.6	Removing the Differential Center	10
3	Installing the Air Locker	12
3.1	Insuring Adequate Oil Drainage	12
3.2	Installing the Carrier Bearings	14
3.3	Approximate Backlash Shimming	15
3.4	Mounting the Ring Gear	17
3.5	Drilling and Tapping the Bulkhead Port	18
3.6	Assembling the Seal Housing	19
3.7	Pre-Load Shimming	20
3.8	Reinstalling the Bearing Caps	23
3.9	Checking the Backlash	24
3.10	Setting Up the Bulkhead Fitting	25
3.11	Profiling the Seal Housing Tube	27
4	Installing the Air System	28
4.1	Mounting the Solenoid	28
4.2	Running & Securing the Air Line	30
4.3	Connection to the Bulkhead Fitting	31
5	Mounting & Connecting the Electrical System	33
5.1	Mounting the Actuator Switch(es)	33
5.2	Wiring the Actuator System	34
6	Testing & Final Assembly	38
6.1	Leak Testing	38
6.2	Reinstalling the Axles	38
6.3	Testing the Air Locker Actuation	41
6.4	Re-Sealing & Filling the Differential	41
6.5	Post-Installation Check List	42
7	Parts List	43
7.1	Exploded Assembly Diagram	43
7.2	Specifications	43
7.3	Itemized Parts List	44



1 Introduction

IMPORTANT :

BEFORE ATTEMPTING TO DISMANTLE YOUR VEHICLE FOR THIS INSTALLATION, PLEASE READ THIS INSTALLATION GUIDE IN ITS ENTIRETY, AS WELL AS ALL APPLICABLE SECTIONS OF YOUR VEHICLE MANUFACTURER'S SERVICE MANUAL.

1.1 Pre-Installation Preparation

This booklet is to be used in conjunction with your vehicle manufacturer's service manual. ARB endeavors to account for every possible variation in vehicle model when publishing its installation guides, and guides are updated regularly as new model information becomes available, however, the rapid and globally varied release of some vehicles makes it difficult to insure that your vehicle model has been accurately accounted for. In the case of any technical discrepancies between this guide and your service manual, we strongly advise that you adhere to the specifications and techniques as documented in your service manual.

Although your *ARB Air Locker* comes complete with all the step by step instructions you will need to supplement your vehicle manufacturer's service manual and install your new differential, ARB recommends that you have your *Air Locker* installed by a trained professional. Many ARB distributors around the world have been fully instructed in *Air Locker* installations by ARB, and have gained a wealth of experience and skill from years of performing similar installations.

Once you begin this installation your vehicle will be immobile until all steps of the installation are complete. Make sure your *Air Locker* kit is the correct model for your vehicle and that it contains all of the parts listed on back cover of this booklet. Also be sure you have appropriately equipped yourself with all the necessary tools, parts, and materials to complete this installation (see section 1.2 *Tool-Kit Recommendations*), and that you have allowed for an appropriate amount of vehicle down time.

HINT :

Place a ✓ mark inside each of the symbols as you complete each step. It is very important NOT to miss any of the steps!

1 Introduction

1.2 Tool-Kit Recommendations

Below is a list of tools and supplies you may need to complete this installation. Requirements for your vehicle may vary. Please consult your vehicle service manual for additional recommendations.

1.2.1 Tools

- Standard automotive sizes (metric and/or imperial) of sockets, wrenches, Alan keys, and drills.
- A dial indicator or other suitable measuring tool for checking ring & pinion backlash.
- A standard automotive feeler gauge.
- A razor knife to cut the nylon tubing.
- A differential housing spreader, to facilitate removal of the carrier.
- A torque wrench. (See vehicle service manual for required torque range.)
- A lubricant drain reservoir.
- Suitable measuring tools to measure a differential for pre-load and/or backlash shimming. (See Section 3.3)
- A 11.2mm [7/16"] drill and 1/4" NPT tap for bulkhead fitting installation.
- An automotive bearing puller (2 jawed is recommended) or a differential carrier bearing puller.
- A bearing press or arbor press.

1.2.2 Supplies

- Thread lubricant/sealant compound for pressure fittings (e.g., LOCTITE #567 Teflon paste)
- Thread locking compound (e.g., LOCTITE #272)
- Either a replacement gasket, or gasket sealant, for your differential cover.
- A sufficient volume of differential oil to completely refill your housing. (see the *ARB Air Locker Operating and Service Manual* for recommended lubricants)
- A soap and water mixture to test for air leaks.
- Teflon paste.

1 Introduction

1.3 Assembly Type Identification

IMPORTANT:

Sections 2 and 6 of this installation guide have been written to accommodate two different Dana 35 applications:

- A** The 'C' clip retained axle shaft (Refer to Fig.1.)
- B** the non-'C' clip type axle shaft (Refer to Fig.2.)

To eliminate confusion, you should identify which figure your axle matches with. The section numbers within the guide that refer ONLY to the 'C' clip type have been suffixed with an **A**, and those that refer ONLY to the non-'C' clip type have been suffixed with a **B**.

PLEASE IGNORE ALL SECTIONS WHICH DO NOT APPLY TO YOUR APPLICATION

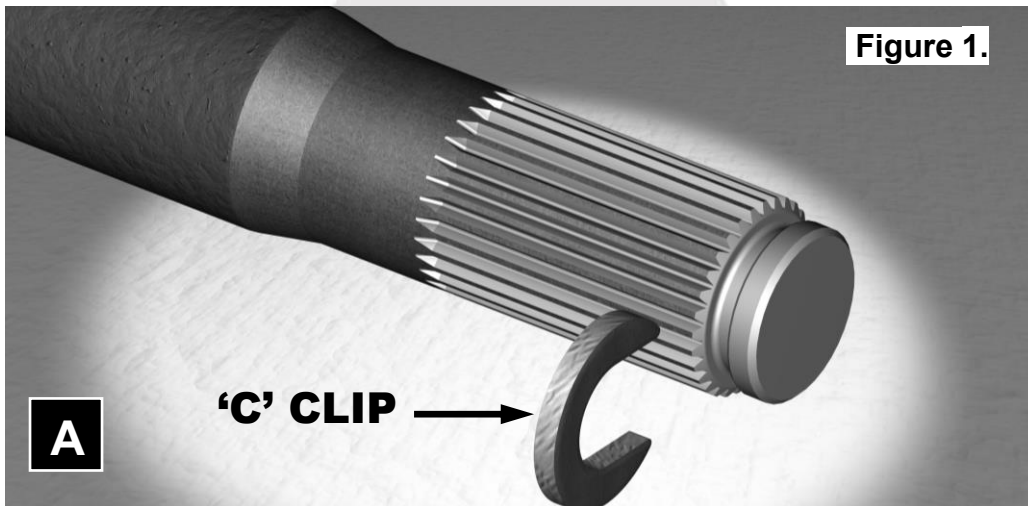

2 Removing the Existing Differential

2.1 Vehicle Support

- Safely secure the vehicle on a hoist. We recommend supporting the vehicle on a chassis hoist to keep the differential area at a convenient working height and to leave the wheels and axles free to be rotated and removed.
- Once supported off the ground, release the parking brake and leave the vehicle in neutral. Chock the wheels if necessary.

2.2 Differential Fluid Drain

HINT : This is a good time to check for metal particles in your oil, on your drain plug, or in the bottom of the housing which may indicate a worn bearing or differential component.

- Clean any loose dirt from around the differential cover flange area, the filler plug area, and the drain plug (if any) to avoid contaminating the differential cavity with abrasive particles.
- Position a fluid drain reservoir under the differential.
- If a drain plug exists, remove it and completely drain all differential oil from the housing.
- If no drain plug exists then the oil can be drained by loosening the cover bolts and gently prying the cover away at the bottom until oil runs out.

HINT : If a drain plug does not exist then it would be a good idea to drill and tap for a tapered oil drain plug to assist with future oil changes.

- Once drained, remove the differential cover plate.

2 Removing the Existing Differential

2.3 Removing the Axles

IMPORTANT :

Collision damage or heavy off-road use of your vehicle in the past may have resulted in some degree of bending in the axle. Any misalignment of the axle tubes may result in excessive wear and/or failure of your differential and axle shafts. ARB strongly recommends that you have your axle assembly inspected for concentricity and straightness before installing your *Air Locker*.

2.3.1 **A** Removing 'C' Clip Retained Shafts

- Remove both of the rear wheels and brake drums/rotors according to your vehicle manufacturer's service manual.
- Rotate the differential carrier using the drive shaft until you have clear access to the cross shaft retaining pin.
- Completely remove the retaining pin by unscrewing it.
- Rotate the differential carrier again until you can completely remove the cross shaft from the differential.
- Tap the axle shafts inward to unseat the 'C' clips from their pockets in the center of the differential side gears.
- Using needle nosed pliers, remove both 'C' clips from the differential.
- Tap the axle shafts outward until the splines are disengaged from the differential side gears.
- Gently slide the axle shafts out of the axle tubes until they can be completely removed from the vehicle.

NOTE : The oil seals are delicate and can be easily damaged. Support the weight of the axle shafts when drawing them out of their sockets in the housing.

2.3.2 **B** Removing Non-'C' Clip Semi-Floating Shafts

- Remove both of the rear wheels and brake drums/rotors according to your vehicle manufacturer's service manual.
- Remove the axle retaining nuts holding the retaining plate to the axle tube assembly.

NOTE : The axle retaining nuts and bolts are not recommended for re-use and should be re-placed at the time of reassembly.

2 Removing the Existing Differential

- Pull the axle free of the axle bearing using a slide hammer.
- Gently slide the axle shafts out of the axle tubes until they can be completely removed from the vehicle.

NOTE : The oil seals are delicate and can be easily damaged. Support the weight of the axle shafts when drawing them out of their sockets in the housing.

2.4 Marking the Bearing Caps

- Using a pointed center punch, gently mark the bearing caps in a way that will enable you to know which cap is 'LEFT' and which cap is 'RIGHT', which way is 'UP' and which way is 'DOWN'. (Fig.3.)

HINT : Many installers choose to make one punch mark on the left hand side of the left hand bearing cap and one similar punch mark on the housing at close proximity to the cap mark. The right hand side is then designated with two punch marks on the right hand side of the cap and two similar punch marks on the housing.



2 Removing the Existing Differential

2.5 Checking the Current Backlash Amount

IMPORTANT:

This step is a precautionary measure recommended by ARB due to the fact that some after market ring and pinion sets have been manufactured to run with different backlash settings than those specified by your vehicle manufacturer. Although ARB must recommend you set backlash according to your service manual guidelines, we also advise that you compare the backlash measurements taken here to the recommended backlash settings in your vehicle service manual. Measurements found to be outside of your service manual recommendations may indicate the need to deviate from those settings in order to achieve quiet running with a good contact mark.

Refer to your vehicle service manual or your local authorized ARB installer for more information.

- Set a depth indicator on one of the ring gear teeth as in figure 4.

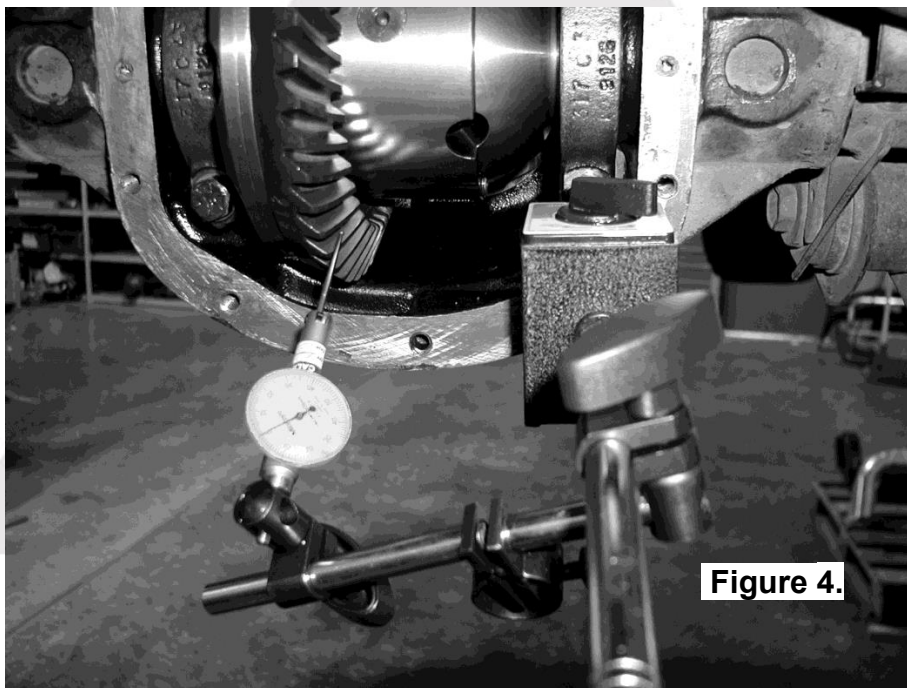

Figure 4.

- While supporting the pinion gear by holding the drive shaft flange, rotate the differential in both directions while observing the maximum variation in depth from the indicator (i.e., the highest value minus the lowest value). This value is referred to as the ring and pinion backlash.
- Rotate the differential center 90° and measure again for accuracy.
- Record the average of all measurements.

2 Removing the Existing Differential

2.6 Removing the Differential Center

IMPORTANT:

YOU MUST SPREAD THE HOUSING ON DANA 35 MODELS

Spreading the differential housing with a differential case spreader is a step which is critical to set up bearing pre-load on cast iron Dana 35 differential housings. Improper pre-load will result in undue bearing wear, increased stresses in the differential center, increased running noise, and ultimately, ring and pinion gear damage.

- Remove both bearing caps.
- Carefully spread the housing (Fig.5.) enough to remove the differential center. (Refer to your vehicle's service manual).

NOTE : Do not spread the housing more than 0.50mm [0.020"].

NOTE : Be sure not to mix up the left and right hand bearing cups and master shims. Later it will be necessary to know which cup and shim came from which side.

- Once the housing has been adequately spread, the differential may be removed by pulling forward on the differential carrier.

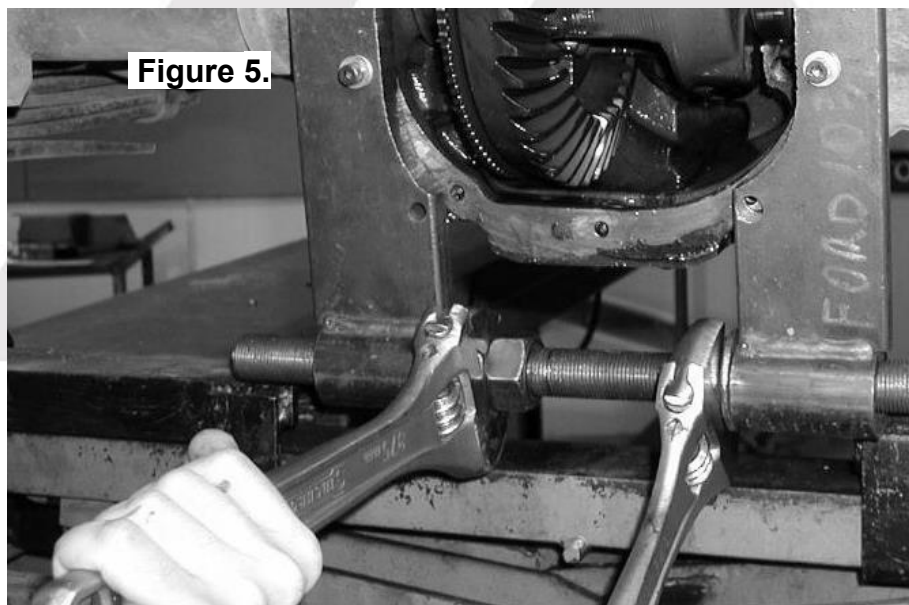

NOTE : The differential center is heavy and quite difficult to handle when covered in oil. Take care not to drop it.

- Relieve any tension on the spreader immediately after the differential has been removed.

3 Installing the Air Locker

3.1 Insuring Adequate Oil Drainage

IMPORTANT:

Some axles were manufactured with poor oil drainage between the axle tubes and the differential housing. This can often result in one of the axle tubes filling up with differential oil while running. In most cases this will result in a blocked air vent which will cause the differential housing to pressurize and expel oil from the axle seals at the wheels or force oil into the air system of the *Air Locker*, eventually expelling oil at the solenoid valve. This is a design flaw which was corrected by most automakers in the later releases of their axle assemblies. If no lower drainage points are present in the differential housing then it is critical that you modify the housing to include them.

- Inspect the differential housing for the presence of adequate drainage in both axle tubes (refer to Fig.6.).

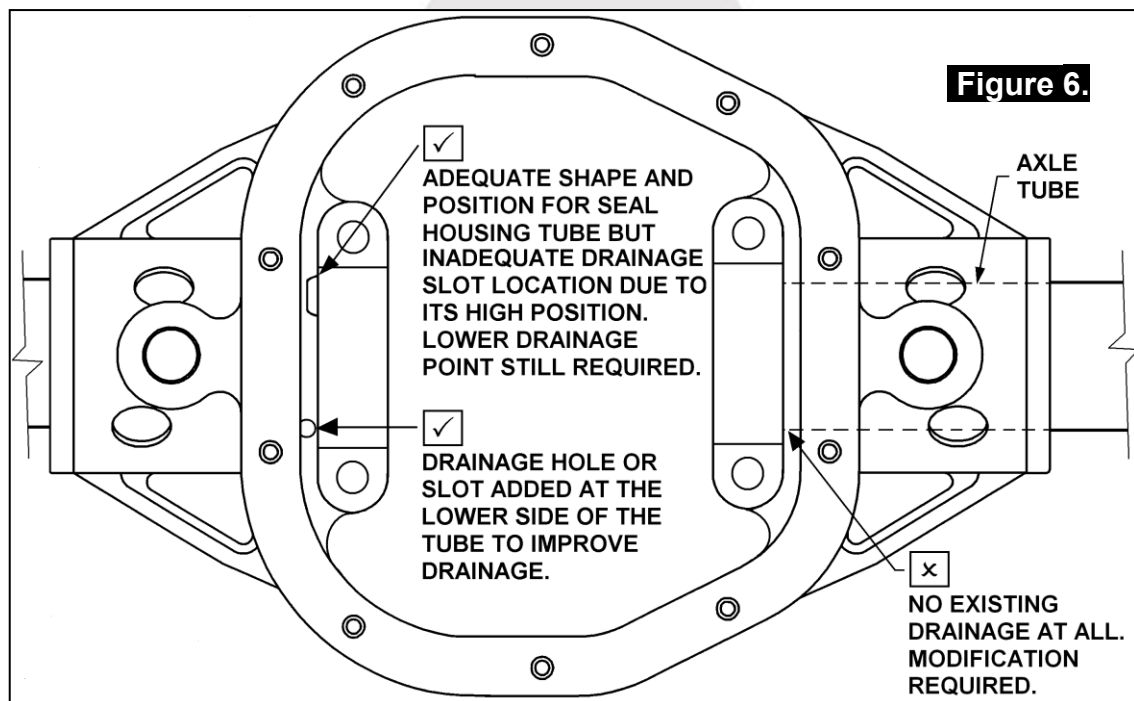

- If no drainage exists then two slots should be created in the bearing seat face of both axle tubes; one on the upper side of the tube, and one on the lower side. Figure 7. shows an example of an axle housing with no existing oil drainage.

3 Installing the Air Locker

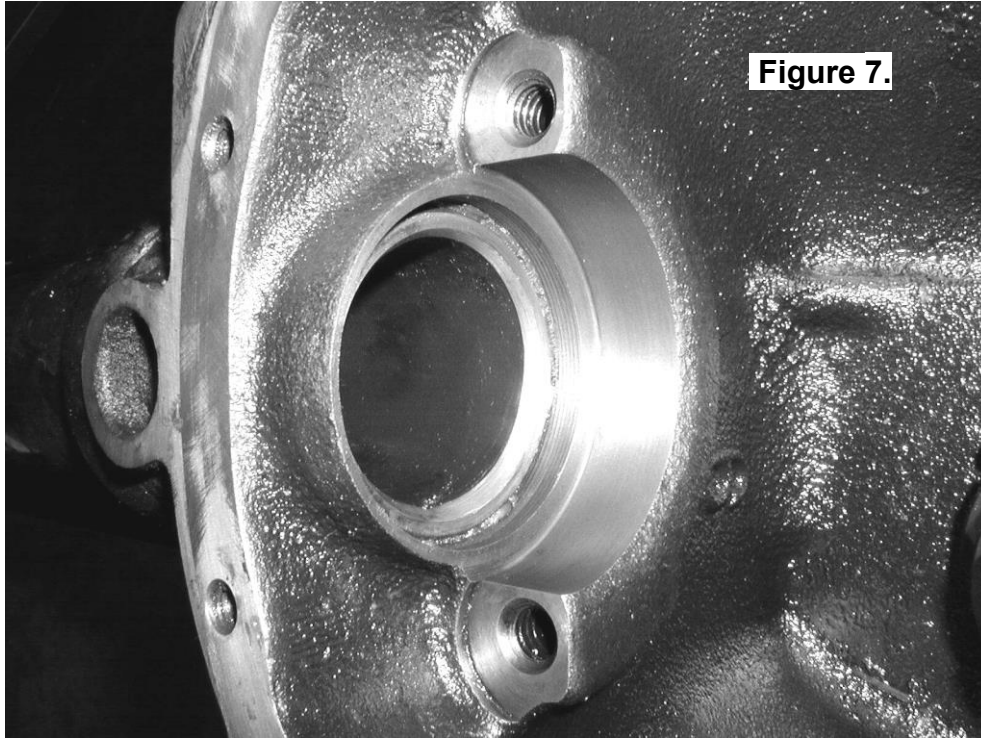

NOTE : Cover the differential housing cavity and the axle tube openings with a rag to protect them from metal filings.

3 Installing the Air Locker

- If no drainage slot is present at the upper left-hand side (refer to Fig.6.) of the housing at all, then a slot (not a hole) will have to be created here as clearance for the seal housing tube (Refer to Section 3.8 *Reinstalling the Bearing Caps*).
- If drainage exists but is inadequate then slots or holes should be cut into the housing on the upper and lower side of the tubes where required.

NOTE : Figure 9. shows upper and lower drainage slots cut into a bearing seat which had no existing drainage at all before modification.

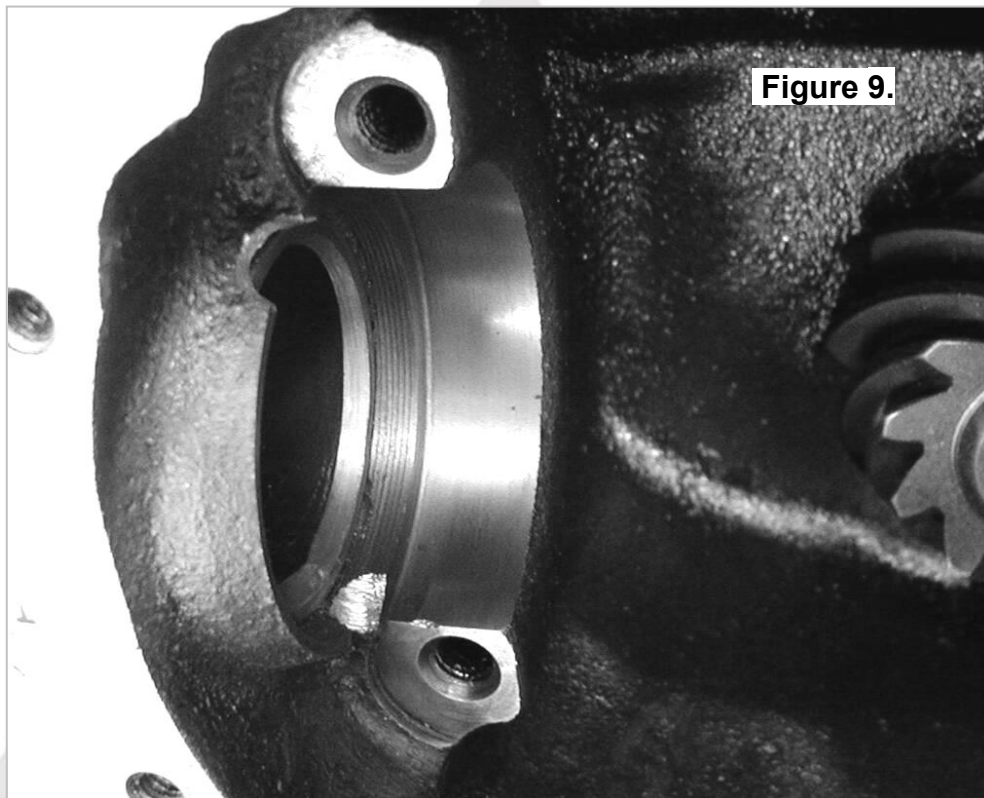

- Remove any sharp edges left behind by the modifications that could break off and fall into the cavity.
- Make sure any grinding dust, filings or drill chips left behind by cutting the drainage slots are completely cleaned out of the housing.
- Check that the axle air vents are clear and working correctly.

3 Installing the Air Locker

3.2 Installing the Carrier Bearings

- Apply a thin film of high pressure grease to both bearing journals of the *Air Locker* to prevent seizing.
- Using a bearing press or arbor press, press one of the bearing cones (supplied with the *Air Locker* kit) onto one bearing journal of the *Air Locker* (refer to Figure 10.) until the bearing seats firmly against the bearing journal shoulder.

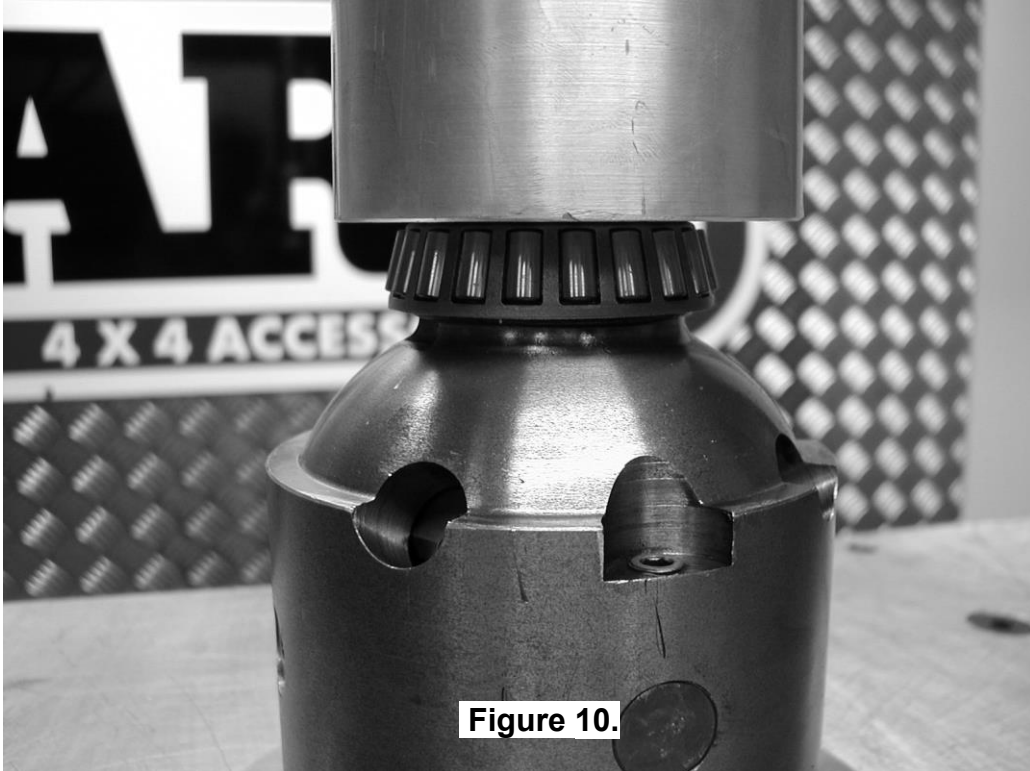

- Invert the *Air Locker* and press the other tapered roller bearing cone onto the opposite bearing journal of the differential carrier until the bearing seats firmly against the bearing journal shoulder.

NOTE : Do not add any shims between the bearings and the bearing seat. Shimming of the *Air Locker* will be performed with the supplied shim kits and/or the original master shims (if any) on the outside of the carrier bearings.

3 Installing the Air Locker

3.3 Approximate Backlash Shimming

In order to reproduce a similar pre-load and ring and pinion backlash in your *Air Locker* to that of your original differential, measurements need to be taken so that a shim thickness can be calculated.

- Secure the original differential to a work bench.
- Remove the bolts that hold the ring gear in place.
- Using a plastic or copper hammer, tap in a circle around the ring gear to separate it from the differential carrier.

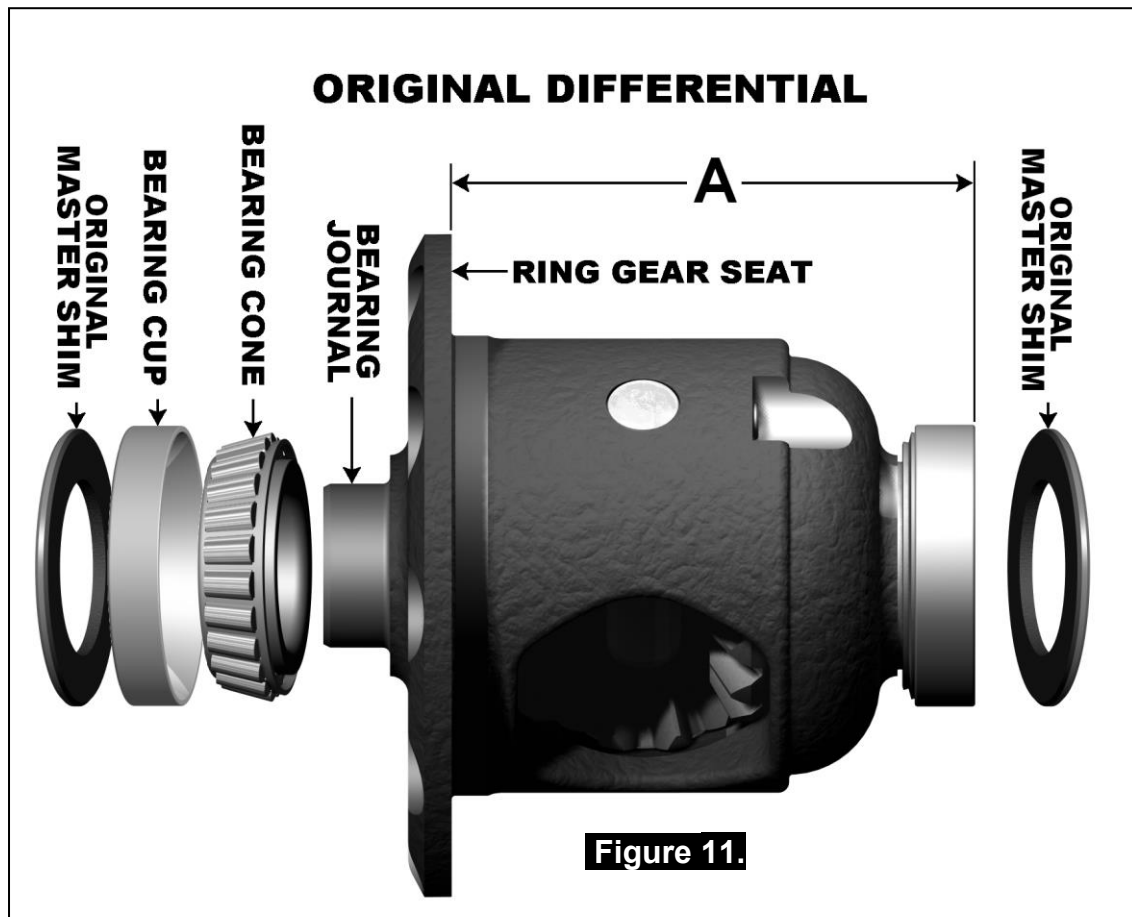

- Assemble the original bearing cup onto the cone of the right-hand side of the original differential carrier.
- Using a caliper or similarly accurate measurement method (i.e., able to take accurate measurements within 0.04mm [0.0015"]), measure the distance from the shoulder of the outer face of the bearing cup to the ring gear mounting face (shown as 'A' in Figure 11.) and record this measurement as 'A'.

NOTE : Be sure to measure using the bearing cup that originally came off of the right-hand side.

3 Installing the Air Locker

- Assemble the new bearing cup and master shim (supplied with your *Air Locker* kit) onto the right-hand side of the *Air Locker* (as shown in Fig.12.) and measure the total distance 'B'.

NOTE : The shim pack 'C' should not be installed at this time.

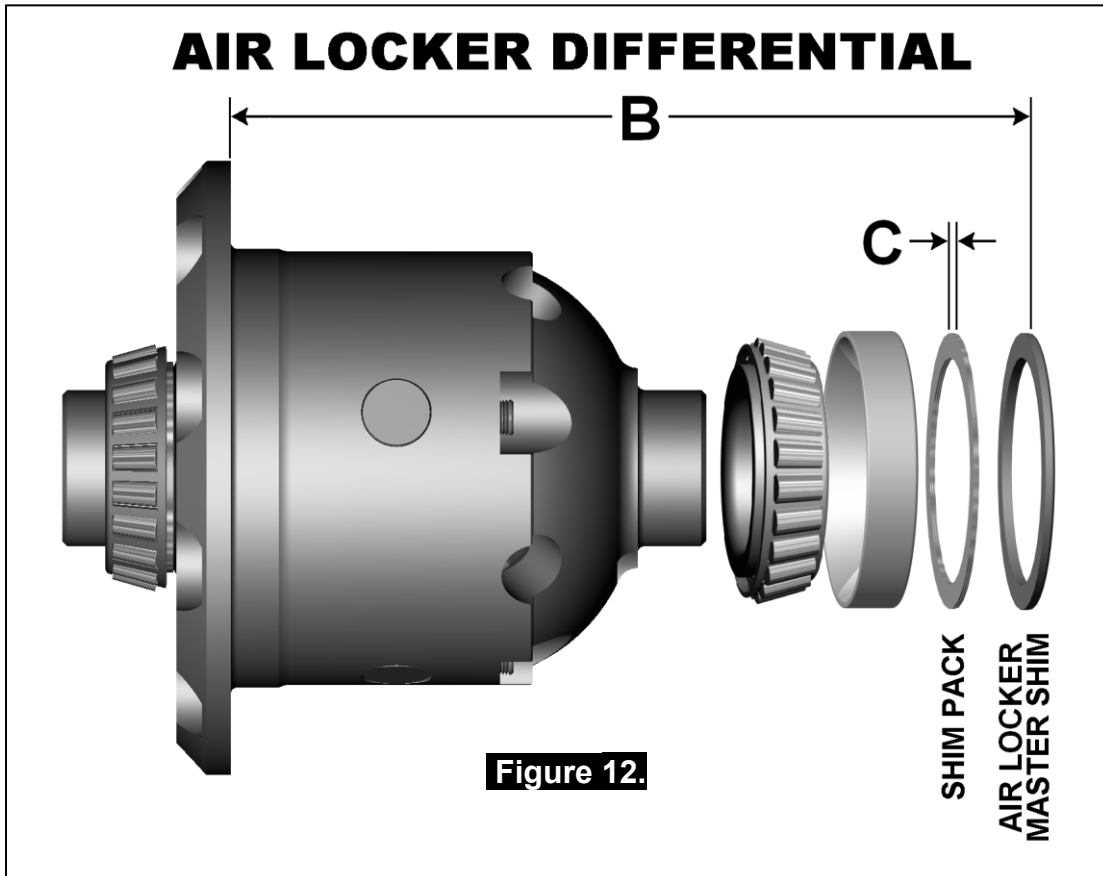

- Record this measurement as 'B'.

The thickness of the shim pack 'C' should make the distance 'B' on the *Air Locker* closely match the distances 'A' on the original differential (within 0.1mm [0.004"]).

- Use the following calculation to find the desired thickness of 'C':

$$A - B = C \text{ (Replacement Shim Pack)}$$

HINT : If your calculations are correct then the following equation will also be true:

$$A - B - C = \text{ZERO}$$

3 Installing the Air Locker

- Select shims from the shim kit supplied with your *Air Locker* to make the thickness 'C' as determined above.
- Place this shim pack between the master shim and the bearing cup.
- Re-measure the new distance 'B' from the *Air Locker* (now including the shim pack 'C') to make sure that it matches the distance 'A' on the original differential.

NOTE : NEVER machine the *Air Locker*.

3.4 Mounting the Ring Gear

IMPORTANT:

Newer OEM Dana 35 ring and pinion sets use 7/16" bolts. The flange holes of the *Air Locker* must be reamed from Ø3/8" to Ø7/16" to suit.

- Apply a thin film of high pressure grease to the ring gear shoulder of the *Air Locker* to prevent seizing.
- Thoroughly clean any thread locking compound or other foreign matter from the holes of the ring gear, the threads of the ring gear bolts, and the mating surfaces between the ring gear and the *Air Locker* flange.

HINT : Stoning the ring gear mounting face before installation will remove any high spots around the threads.

- Heat the ring gear to between 80 and 100°C [175 - 212°F] in hot water or in an oven to slightly expand the gear and facilitate assembly.

NOTE : **NEVER HEAT GEARS WITH A FLAME!** This could damage the hardened surface of the gear and result in premature wear or failure.

- Dry the gear and bolt holes with compressed air (if wet).
- Install the ring gear onto the *Air Locker* by aligning the bolt holes and then gently tapping it around in a circle with a soft mallet. Avoid using the bolts to pull down the ring gear as this puts excess strain on the bolts and the differential flange.
- Apply a thread locking compound to the thread of each ring gear bolt before inserting it. Do not apply threading compound directly into the threaded hole as this could prevent the bolt from reaching its full depth.
- Tighten the ring gear bolts in a star pattern with a torque wrench according to your vehicle manufacturer's specified torque.

3 Installing the Air Locker

3.5 Drilling and Tapping the Bulkhead Port

An airline port must be drilled and tapped through the differential housing to mount the bulkhead fitting into.

NOTE : Higher ratio gearing uses deeper (thicker) ring gears with teeth that extend much further. Make sure the intended hole location is far enough away from the ring gear teeth that the air line will not be at risk of contact with the current or future ring gears.

- Mark a spot on the top of the outside shell of the differential housing approximately 30mm [1.25"] in as shown in Figure 13.

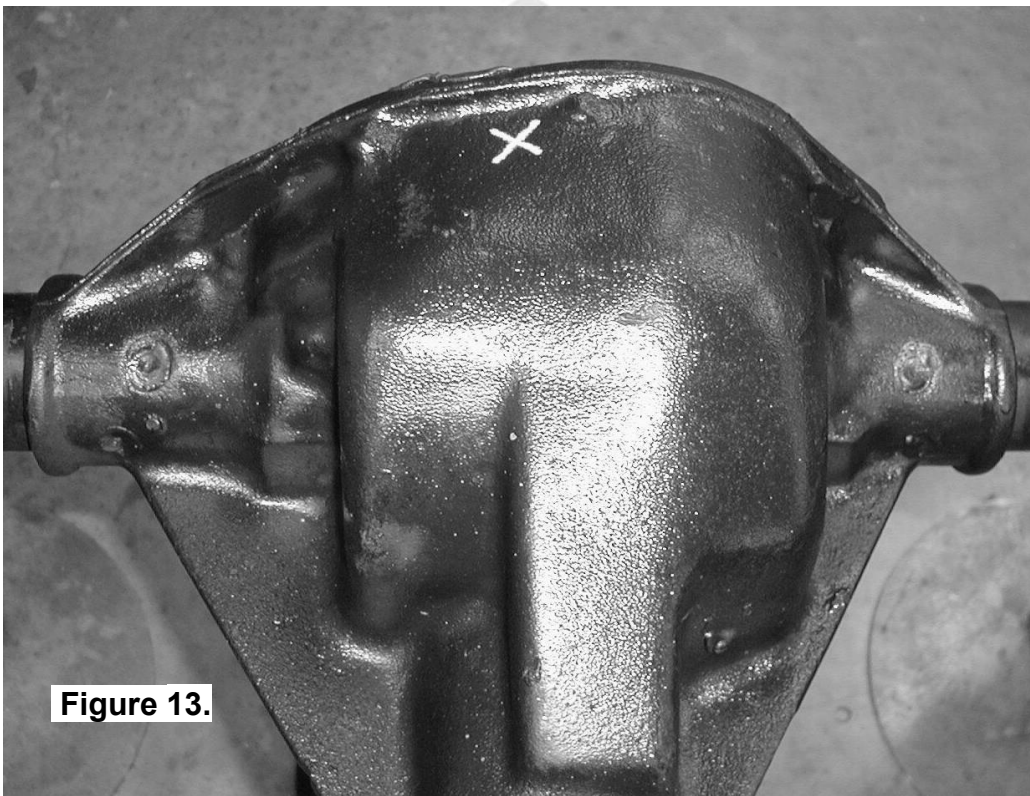
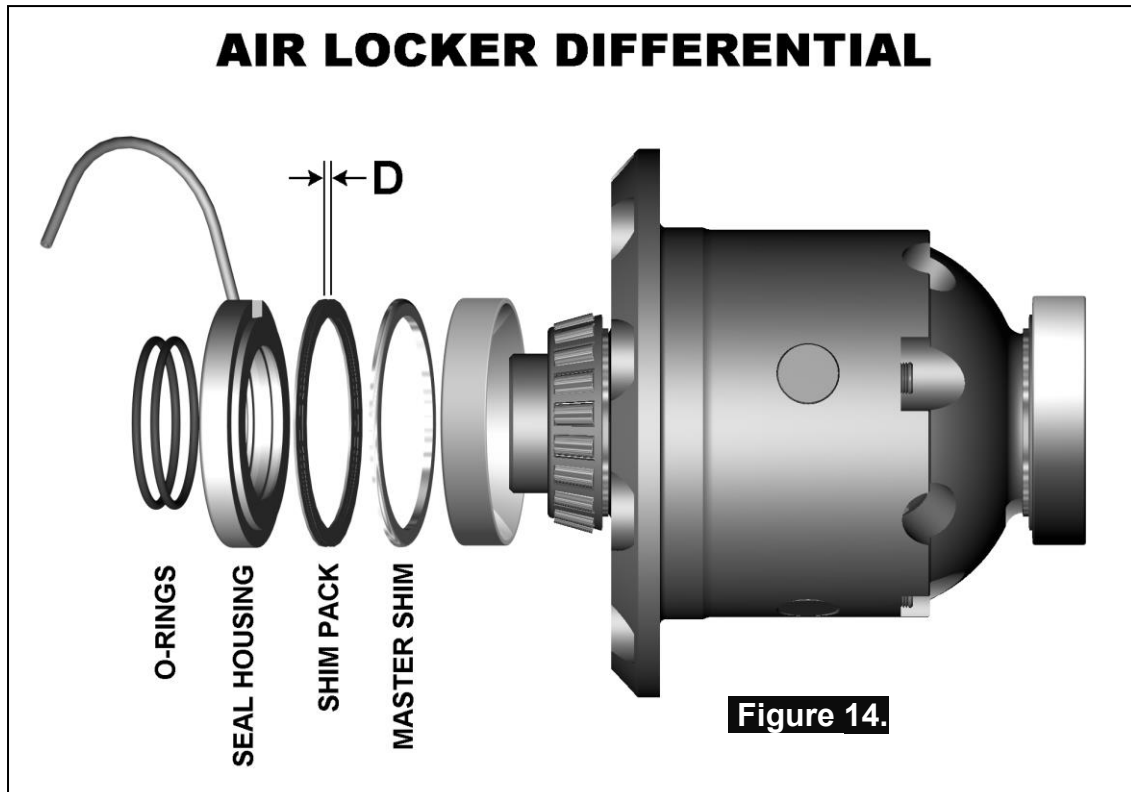

Figure 13.

- Cover the drive pinion and axle tube areas with a rag to protect them from metal filings.
- Drill through the housing square to the outside surface using a 11.2mm [7/16"] drill.
- Tap the hole from the outside using a 1/4" NPT pipe tap.
- Remove any sharp edges from the hole that may chip-off and fall into the housing.
- Carefully remove the rags and inspect with a service light inside the housing to insure no metal filings are left behind.

3 Installing the Air Locker

3.6 Assembling the Seal Housing



- Make sure the grooves and airway of the seal housing are clean and free from any contaminants (e.g. water, dirt, metal filings, etc.).
- Inspect the seal housing O-rings (supplied) for dirt, damage or other conditions which might cause leaks.
- Generously lubricate the O-rings with oil prior to assembly, then insert them into the grooves of the seal housing.

NOTE : When assembling the O-rings, be careful not to leave them twisted when seated in the grooves as this could cause excessive wear and leakage.

- Lubricate the seal housing running surface on the *Air Locker* carrier with oil. Assemble the bearing cup onto the left-hand side of the *Air Locker*.
- Assemble one of the two master shims (included with the *Air Locker* shim kit) onto the stepped face of the seal housing with the rounded edge of the shim facing out.

NOTE : No shims other than the single master shim should be assembled onto the seal housing at this time.

- Carefully install the seal housing (**master shim towards the center**) by sliding it all of the way onto the bearing journal with a gentle twisting motion. This will allow the O-rings to engage gently.

3 Installing the Air Locker

3.7 Pre-Load Shimming

In order to pre-load the tapered roller bearings in your *Air Locker*, measurements need to be taken so that a value can be calculated for the shim thickness 'D' in Figure 14.

- Insert and hold the *Air Locker* into the differential housing.

IMPORTANT:

Some Dana 35 pinion gears extend so far into the differential cavity that they make contact with the body of the *Air Locker*. If this is the case then the end of the pinion gear will have to be carefully ground or machined away until at least 0.5mm [0.020"] of clearance exists. This will not adversely effect the strength of the pinion gear.

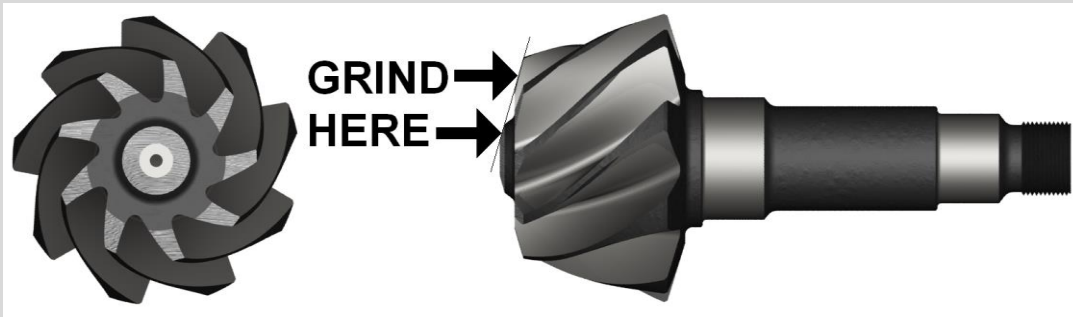

Clean all grinding particles from the pinion gear & differential housing after modifications.

NEVER MODIFY THE AIR LOCKER TO CREATE CLEARANCE.

- Insert the remaining master shim from the *Air Locker* shim kit between the right-hand bearing cup and the bearing seat of the axle housing with the rounded edge of the master shim facing away from the center.
- Insert the shim pack determined earlier as 'C' between the bearing cup (right-hand side) and the master shim.
- Insert the original master shim from the right-hand side of the original differential back into the housing between the *Air Locker* master shim and the bearing seat of the axle housing.
- Push (or lightly pry) the *Air Locker* hard across to the right-hand side, and measure the maximum gap (also called the 'end float') between the outside of the seal housing and the inside face of the axle housing with an automotive feeler gauge. (Fig.15.)

3 Installing the Air Locker

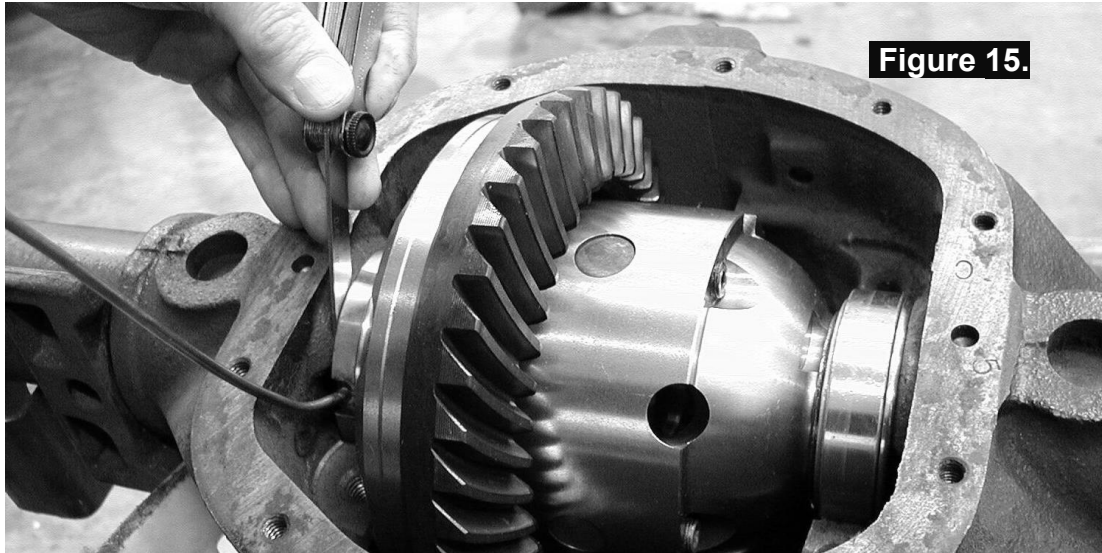

- Consult your vehicle manufacturer's service manual to determine the carrier bearing pre-load amount specified for your vehicle.

PRE-LOAD + END FLOAT = SHIM PACK

- Add the specified pre-load amount to the measurement taken with the feeler gauge to determine a shim amount for 'D' in Figure 14.
- Create a shim pack 'D' from the shims supplied with your *Air Locker*.

NOTE : Do not add shims between the bearing cone and the bearing seat and **NEVER** machine the *Air Locker*.

- Remove the *Air Locker* from the axle housing.
- Install the shim pack 'D' between the master shim and the seal housing as shown in Figure 14.
- Spread the differential housing again (Refer to Section 2.6).
- Re-install the *Air Locker* assembly into the axle housing without the original master shim from the right-hand side.
- Rotate the seal housing until the tube is positioned in the center of the oil drainage notch of the axle housing.
- While holding the *Air Locker* into the axle housing, lightly tap the original right-hand master shim into place on the right-hand side between the *Air Locker* master shim and the bearing seat of the axle assembly. (Refer to Figure 16.)

3 Installing the Air Locker



NOTE : If the master shim is too tight to fully install then the spreader tension may need to be increased. Do not spread the housing more than 0.50mm [0.020"].

- Release all spreader tension.
- Check that some backlash can be felt between the ring and pinion gears. No backlash would be an early indication of incorrect shim thickness.

3 Installing the Air Locker

3.8 Reinstalling the Bearing Caps

IMPORTANT:

The *Air Locker* master shim must be assembled between the stepped side of the seal housing and the bearing cup.

**NOT HAVING THE MASTER SHIM IN PLACE
HERE WILL CAUSE BEARING FAILURE.**

- Using a soft instrument such as a piece of wood, bend the seal housing tube outward and away from the position of the bearing cap and into the drainage groove area. (Fig.17.)

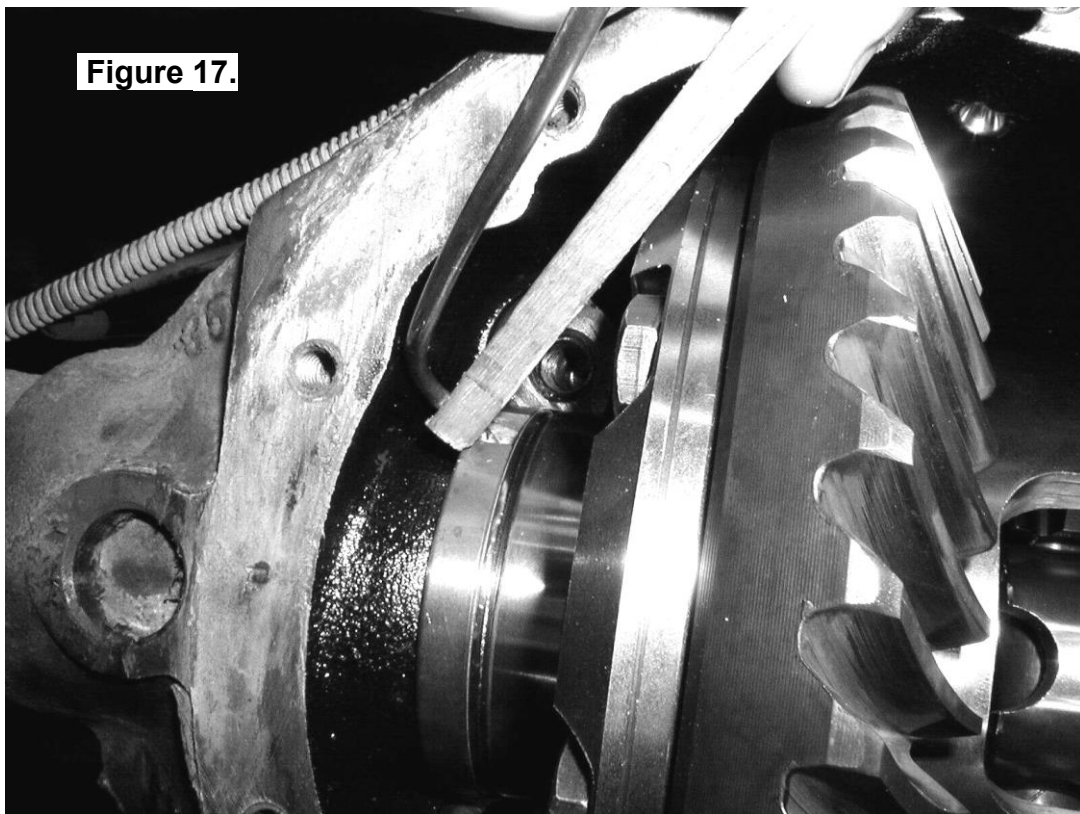

Figure 17.

NOTE : The seal housing tube should lay as low in the seal housing groove as possible.

- Install the bearing caps oriented as they were marked before they were removed, and tighten the bearing cap bolts. It is not necessary to torque them down at this time.
- Check that some clearance exists between the bearing cap and the seal housing tube. If not, the bearing cap should be removed and the tube re-bent for adequate clearance.
- Tighten all bearing cap bolts with a torque wrench to the torque specified in your vehicle manufacturer's service manual.

3 Installing the Air Locker

3.9 Checking the Backlash

- Set a depth indicator on one of the ring gear teeth as in Figure 18.
- While supporting the pinion gear by holding the drive shaft, rotate the differential in both directions while observing the maximum variation in depth from the indicator (i.e., the highest value minus the lowest value). This value is referred to as the ring and pinion backlash.
- Rotate the differential center 90° and measure again for accuracy.

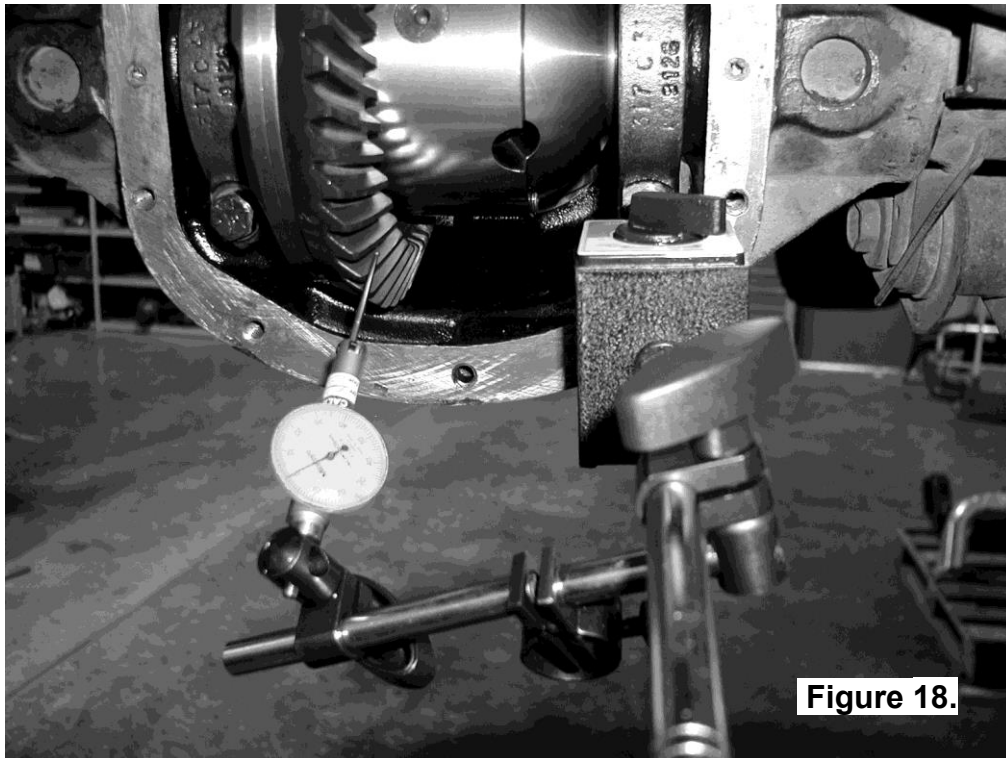

- Refer to your vehicle service manual for the specified maximum and minimum amounts of backlash. If the backlash is not within the specifications then the differential will have to be removed and re-shimmed.

3 Installing the Air Locker

3.9.1 Re-Shimming the Backlash

NOTE : This step is only necessary when adjusting for incorrect backlash.

- Remove the bearing caps.
- Remove the differential as before.
- To decrease the amount of backlash, reduce the shim thickness 'C' (Fig.12.) and increase the shim thickness 'D' (Fig.14.) by the same amount. Reverse this step to increase the backlash.
- Remount the differential as before.
- Release spreader tension (if applicable).
- Check backlash again as before.

3.10 Setting Up the Bulkhead Fitting

- Apply thread sealant to the outside threads of the bulkhead body.
- Screw the bulkhead body into the tapped hole, and lightly tighten using a 14mm [9/16"] spanner.
- Wipe the area clean of any excess thread sealant (inside and outside of the housing).
- Insert the free end of the seal housing tube into the bulkhead fitting until it protrudes approximately 8mm [5/16"] through the other side.
- From the outside of the housing, assemble one of the small O-rings over the top of the short length of seal housing tube protruding through the bulkhead fitting.
- Install the brass spacer.
- Install the second small O-ring after the spacer.
- While holding the seal housing tube into the bulkhead fitting, insert the chamfered end of the center compression nut over the extended tube as shown in the assembly diagram (Fig. 19.), and screw it into the bulkhead body, and tighten using Pozidriv #3 screwdriver.

3 Installing the Air Locker

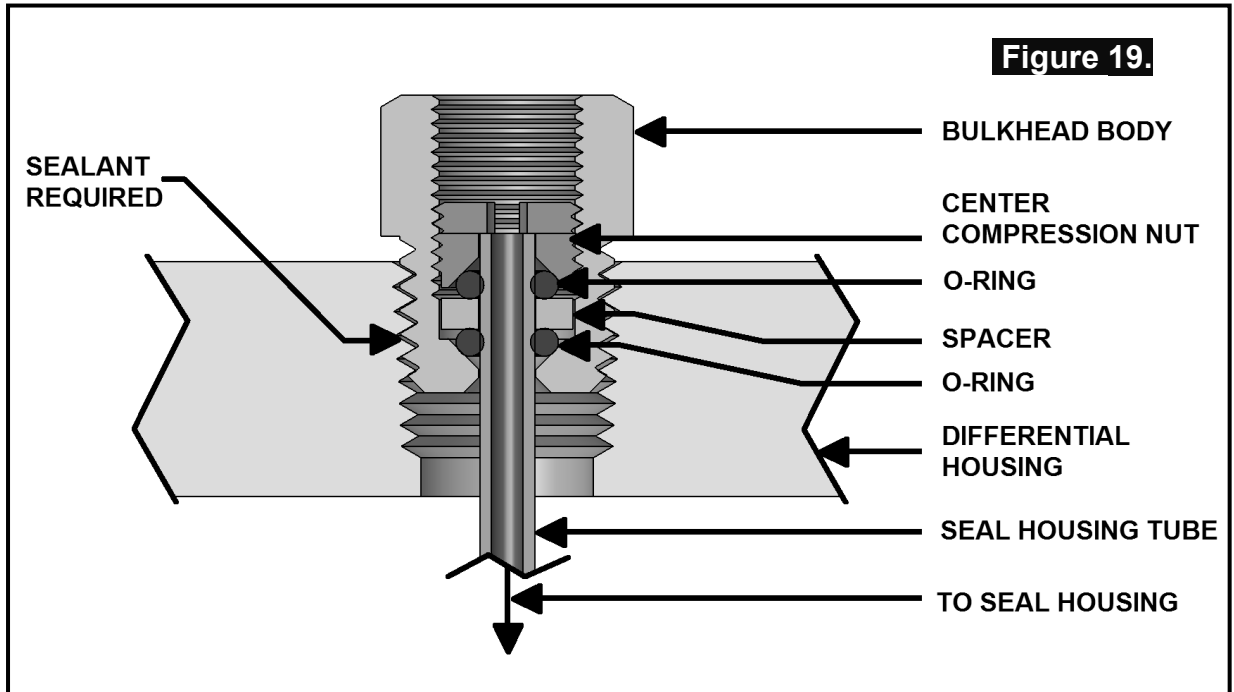

NOTE : Make sure the seal housing tube is all of the way into the center compression nut while you are tightening it.

NOTE : Firmly tighten the center compression nut so that a good seal is formed around the tube.

3 Installing the Air Locker

3.11 Profiling the Seal Housing Tube

- Completely remove the differential spreader.
- Without using sharp, jagged tools such as pliers (usually your hands are the best tool for this job), gently bend the seal housing tube so that it runs along the inside of the differential housing as shown in Figure 20.

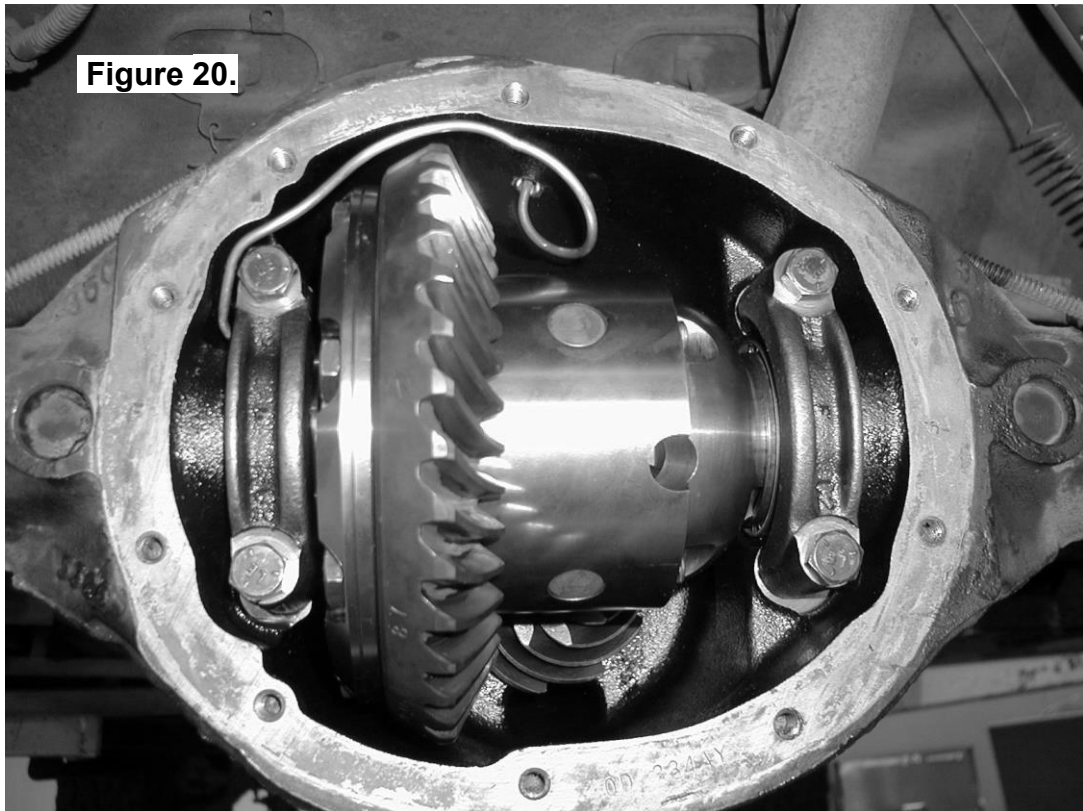

NOTE : It is also a good idea to keep the tube away from the bearing caps or any other part of the differential casting as any contact due to vibration or shock may wear the tube and eventually cause a leak.

6 Mounting & Connecting the Electrical System

4.1 Mounting the Solenoid

4.1.1 Connection to an ARB Air Compressor (Fig.21.)

- Remove one of the 1/8" BSP plugs from its port in the compressor tank.
- Apply Teflon paste to the 1/8" BSP nipple on the solenoid and insert it into the port and tighten. The solenoid should be rotated into a position which does not obstruct any other ports on the compressor tank.

NOTE : The coil and stem of the solenoid can be removed to make installation easier.

NOTE : The solenoid is marked with two #1 ports. If space is tight, a second solenoid can be "daisy-chained" off the first one by removing the plug from the redundant #1 port and screwing the nipple from the second solenoid into it (Fig. 21.).

NOTE : The solenoid exhausts compressed air through the center of the black retaining cap when the *Air Locker* is disengaged. Make sure this orifice cannot be obstructed.

- Assemble the 6mm push-in fitting into the solenoid outlet port (stamped "2") and hand tighten.

Figure 21.

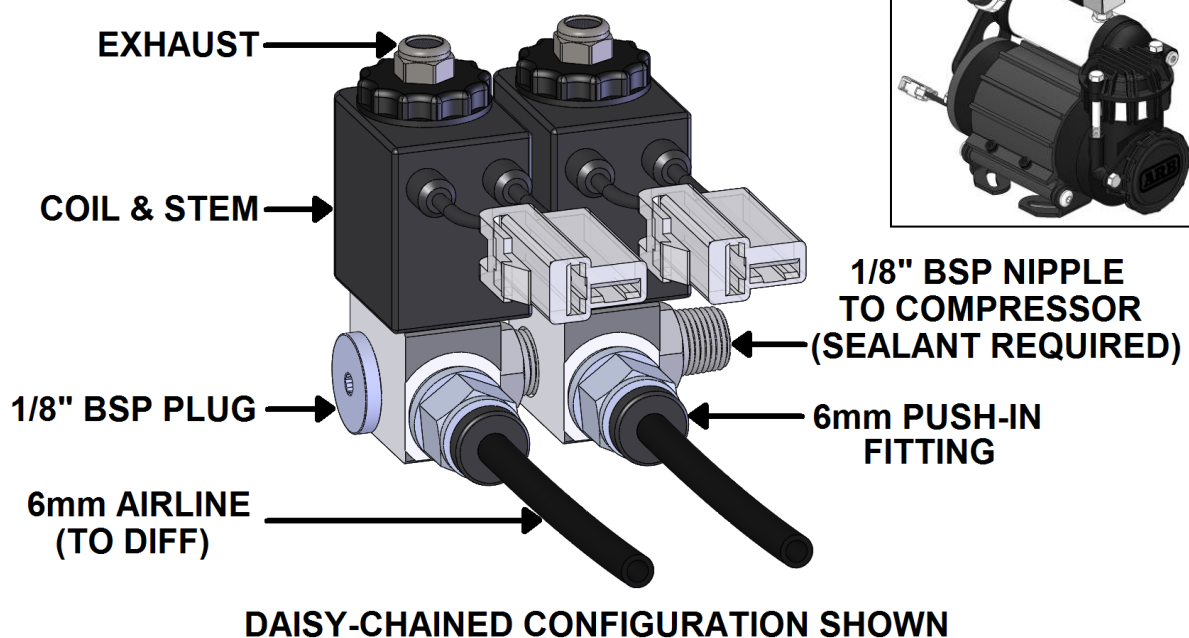

6 Mounting & Connecting the Electrical System

4.1.2 Connection to an Alternate Air Source

For ease of installation, quality of air supply, and a high level of dependability from your *Air Locker(s)*, ARB strongly recommends use of a genuine ARB Air Compressor, however, the *Air Locker* air system can be operated on any alternate air source that meets each of the following guidelines:

- Must supply a minimum of 85PSI [586kPa].
- The Air source should have a tank capacity that enables it to actuate the *Air Locker(s)* in one charge so that no hesitation is experienced when locking one or two differentials.

HINT : A good way to insure that you have the necessary capacity is to make sure you can engage, disengage, and then reengage your *Air Locker(s)* without the air source having to regenerate (e.g., without the compressor turning on to refill the tank).

- Must supply clean air, free of rust, dirt, water, or other foreign matter.
- Must match the 1/8" BSP porting of the *Air Locker* solenoid.
- Mount solenoid within close proximity of the air supply and secure it from the effects of vibration and shock.
- Connect the air supply to the 1/8" BSP inlet port of the solenoid (stamped "1" on the solenoid body) using thread sealant.

IMPORTANT :

ARB cannot warrant your *Air Locker(s)* against damage caused as a result of using an alternate air supply. If you have any doubts as to the suitability of your air system to use in an *Air Locker* system, consult your ARB distributor.

6 Mounting & Connecting the Electrical System

4.2 Running and Securing the Air Line

The path taken by the air line from your air source (i.e., compressor) to your *Air Locker* is unique to your vehicle and the position of your air source. Plan ahead carefully when running the air line and always follow these guidelines:

- Account for axle travel when running the line from the axle to a fixed point on the vehicle. Leave enough slack in the air line to allow for maximum suspension travel in both directions.
(Not necessary on IFS installations)
- Avoid leaving large lengths of air line hanging underneath the vehicle where they may get tangled on rocks, sticks, etc.

HINT : **Cable tying the air line to one of your flexible brake lines will account for axle travel and should help keep your line from getting snagged.**

- Run the air line all the way from the compressor to the differential before trimming either end of the line to length. This will save complications that may arise if the air line has to be removed.
- Make sure the line does not contact sharp edges or abrasive surfaces that may damage the air line over time.
- Do not run the air line around tight bends which may kink the air line and restrict or block the air flow.
- Keep the air line well away from your vehicle's exhaust components. Air lines will melt if subjected to extreme heat.
- Do not run more air line than necessary. Excess line volume created when coiling the left over hose, using unusually large diameter hose, etc., will increase drain on the compressor tank resulting in the compressor running more often than needed.
- Support the air line by tying it back with cable ties wherever possible.
- At the solenoid end of the air line, always trim the line to length with a sharp knife to avoid distorting the tube where it plugs into the push-in fitting.

NOTE : **To remove the air line from the push-in fitting; while holding the flange of the fitting out, push the air line into the fitting as far as possible, then press the flange inward, then pull the air line free of the fitting.**

6 Mounting & Connecting the Electrical System

- To attach the air line to the push-in fitting of the solenoid; insert the line firmly into the fitting, pull outward on the flange of the fitting while holding the line as far into the fitting as possible, and then gently pull outward on the air line to clamp the line in place.

4.3 Connection to the Bulkhead Fitting

- In the case of an IFS axle assembly or in the case that the axle assembly has been completely removed from the vehicle, the assembly will have to be remounted in order to position the bulkhead fitting in its correct location for air line access.
- Trim the air line to length using a sharp knife.
- Assemble an aluminium washer onto the banjo bolt and insert through the banjo fitting. Assemble second aluminium washer and tighten into bulkhead fitting using a 14mm [9/16"] spanner. (Fig.22.)
- Apply thread sealant to the tapered thread of the compression fitting body and screw into the banjo fitting. Tighten using a 12mm spanner.
- Insert the outer compression nut and ferrule over the air line. Ferrule should be orientated as per Fig.22.

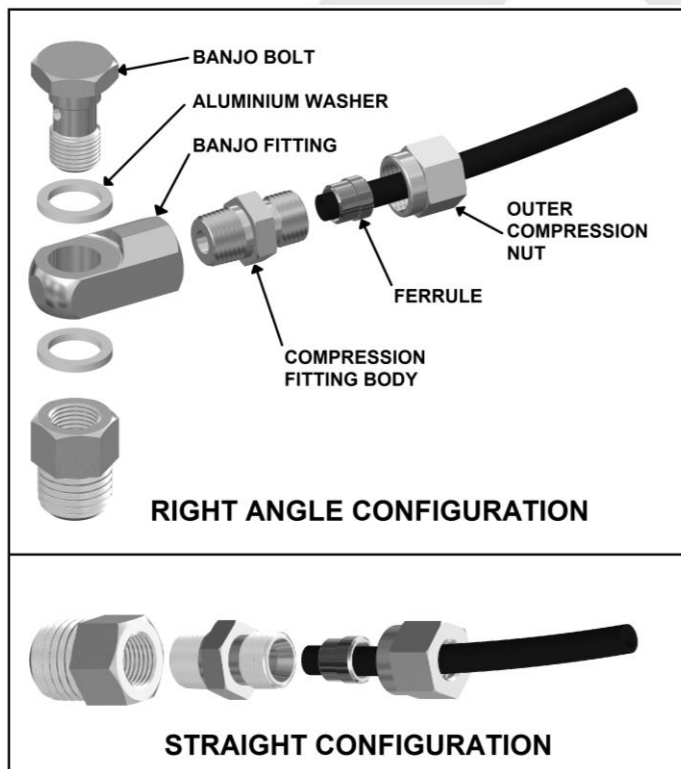

Figure 22.

6 Mounting & Connecting the Electrical System

- Push the airline into the compression fitting body and screw the outer nut down onto it. Using a 12mm spanner, tighten the outer nut onto the compression fitting body.

NOTE : Some force is required to crush the ferrule, however the outer compression nut will tighten against a stop. Over tightening will not create a better seal.

- Secure any loose sections of tube with a cable tie.

NOTE : When right angle routing of the tube is not required, screw the compression fitting body straight into the bulkhead fitting body (Fig.22.).



5 Mounting & Connecting the Electrical System

5.1 Mounting the Actuator Switch(es)

Air Locker actuator switch(es) can be easily panel mounted inside the vehicle in a 21mm x 36.5mm [0.83" x 1.44"] rectangular cutout.

NOTE : Only attach the cover plate to the face of the switch once the switch has been mounted and wired correctly as the cover plates are designed to be difficult to remove.

For reasons of safety and for ease of operation, the *Air Locker* actuator switch(es) should be mounted in a location picked to best suit the operator. Make sure you have taken the following points into consideration:

- Switch(es) MUST be mounted and should never be allowed to simply dangle from the wiring loom during vehicle use.
- Switch(es) should be within easy reach of the driver. Ideally, any *Air Locker* switch should be able to be operated without physical effort or distraction to the driver.
- Switch(es) should be mounted within the line of sight of the driver so that switch position ('ON' or 'OFF') can be visually determined by the rocker position and the illumination state.
- The position of the switch(es) should best eliminate any possibility of accidental operation by the driver or one of the passengers.
- Switch cutout position(s) must be located in an area with a minimum of 50mm [2"] of clearance behind the face of the cutout.
- Switch(es) should not be mounted where they will be exposed to water (e.g., in the lower section of an inner door panel).
- ARB recommends that you apply the *Air Locker* Warning Sticker (ARB part # 210101) within close visual proximity of the switch location.

NOTE : If no adequate position can be found on existing dashboard panels, a surface mounted bracket (Fig. 23.) may be purchased from your ARB *Air Locker* distributor to suit 1, 2, or 3 switches.

5 Mounting & Connecting the Electrical System



5.2 Wiring the Actuator System

5.2.1 Connection to an ARB Air Compressor

When wiring the *Air Locker* actuator switch(es) and solenoid(s) to an ARB Air Compressor, all connections can easily be set up directly from the supplied wiring loom. (Fig. 24.)

NOTE : 180409 model loom shown for reference only. Refer to your ARB Air Compressor Installation Guide for details on configuring your installation.

5 Mounting & Connecting the Electrical System

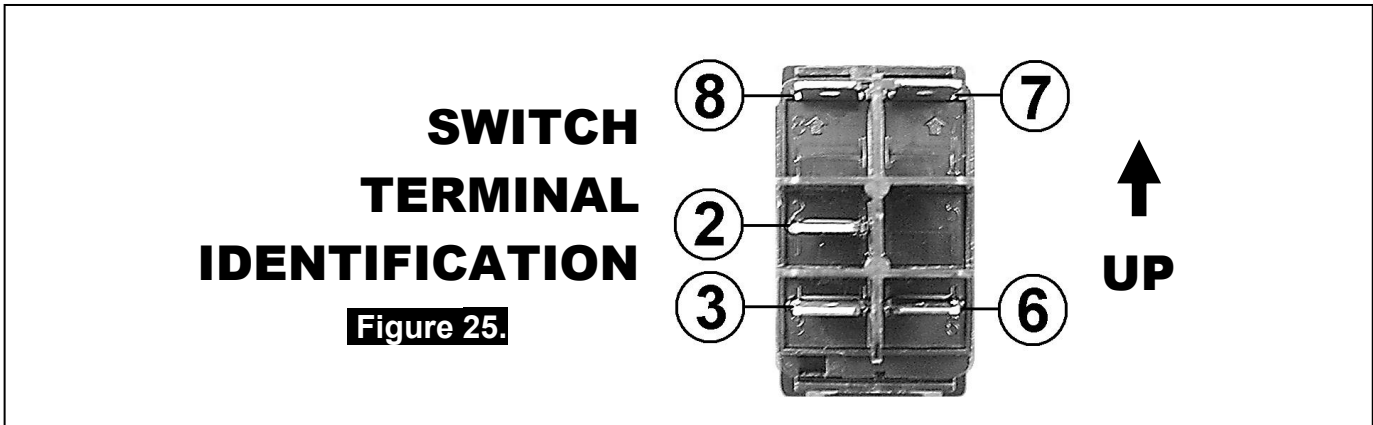
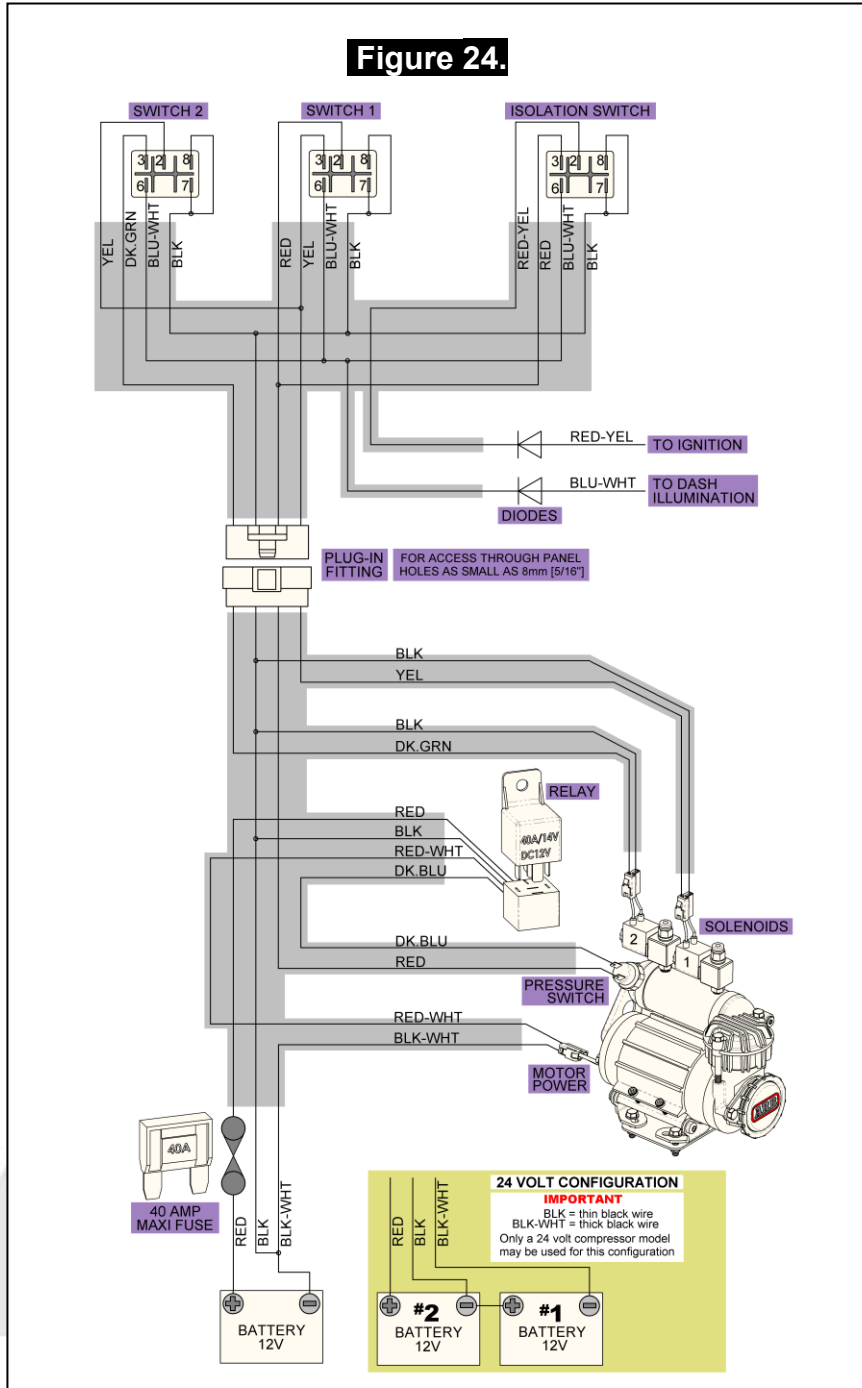

5 Mounting & Connecting the Electrical System

5.2.2 Connection to an Alternate Air Source

When connecting the actuation switch to an alternate air source, the switch(es) should be wired according to figures 26. and 27., depending on whether one or two *Air Lockers* will be installed in the vehicle.

5.2.2.1 Single Air Locker System

- If only one *Air Locker* is to be installed in the system, the switch and solenoid should be wired according to figure 26. regardless of whether the *Air Locker* has been installed in the front or rear axle of the vehicle.
- Attach the appropriate switch cover (i.e., 'FRONT' or 'REAR') to the switch.

NOTE : Refer to Figure 25. for the correct switch terminal identification and switch orientation.

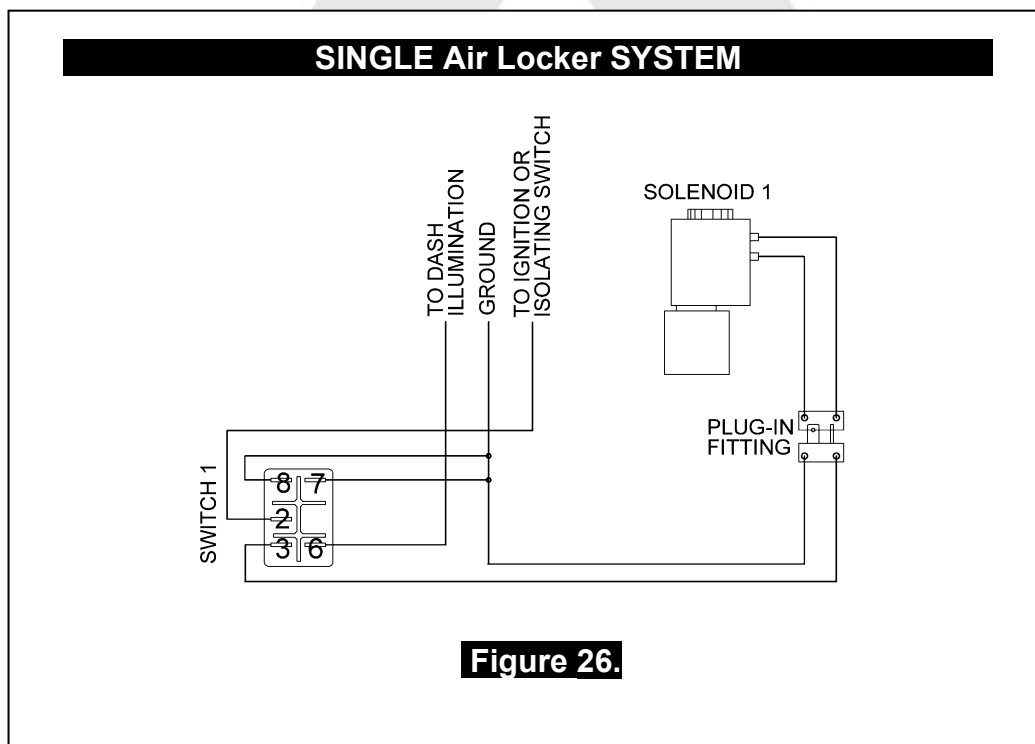

6 Testing & Final Assembly

6.1 Leak Testing

- With the vehicle parked and the engine off, turn the compressor on and wait until the air system is fully charged.

NOTE : With the *Air Locker(s)* disengaged, the air source (i.e., compressor) should not have to recharge over time. Intermittent recharging without *Air Locker* use usually indicates a leak at the solenoid fittings or at the compressor tank O-ring seal.

- Actuate the *Air Locker(s)*.
- The compressor should not come on again for a period of at least 15min. Air system recharging within that time period would indicate that a leak is present in the system.

NOTE : If an alternate air source (e.g., an air cylinder or a belt driven air pump) is used instead of a compressor, the air system will have to be leak tested with a pressure gauge and a shut-off valve in series before the solenoid input.

- If a leak is found to be present, spray a soap and water mixture onto all air fittings in the system while the compressor is fully charged. Bubbles should appear at any leak points.
- Check that leaky fittings have been adequately tightened.
- Disassemble, clean threads, and reapply thread sealant if leaking persists.

6.2 Reinstalling the Axles

- Unscrew and remove the long cross shaft retaining pin using a 5mm hex key.

NOTE : The long cross shaft retaining pin is the pin located exactly one quarter turn of the differential from the 'C' clip access window. Rotate the differential using the drive flange.

6 Testing & Final Assembly



6.2.1 A Reinstalling 'C' Clip Retained Shafts

- Remove the long cross shaft.



- Rotate the differential until the 'C' clip access window is in full view.
- Insert both axles fully into the housing and gently tap them inward as far as they will go.

NOTE : To prevent damage to the oil seals, support the weight of the axle shaft when inserting them.

- Using needle nosed pliers, insert one of the 'C' clips onto the groove in the axle shaft by sliding it between the spider block and a side gear. (Refer to Figure 30.)

NOTE : You may have to slide the axle shaft outward very slightly to adequately line up the groove.

6 Testing & Final Assembly

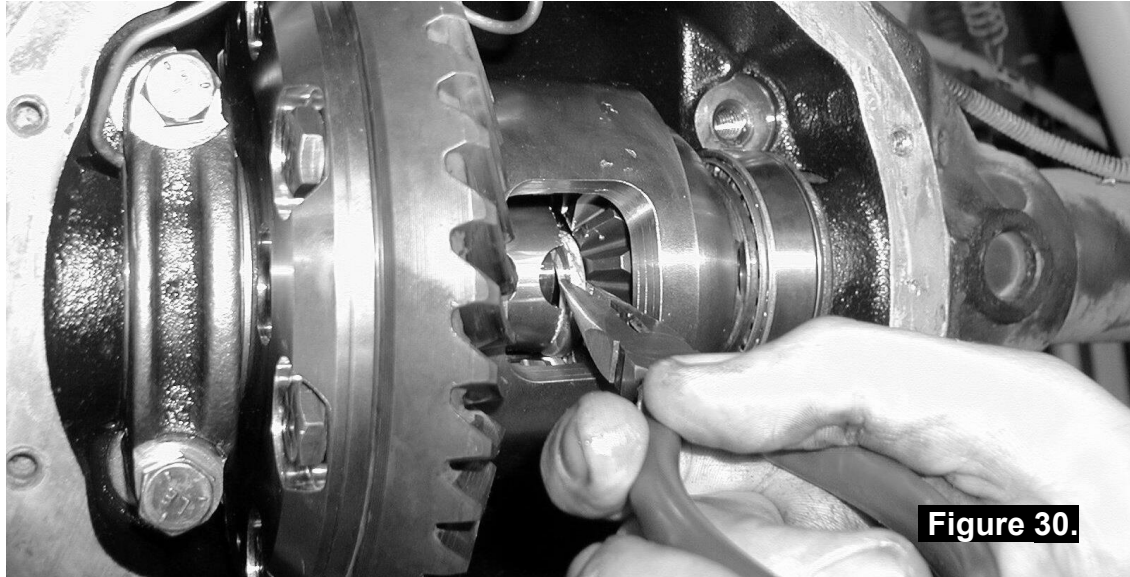

- Pull outward on the axle shaft to seat the 'C' clip into the side gear.
- Repeat the 'C' clip installation steps on the second axle shaft.
- Re-insert the long cross shaft.
- Using an automotive feeler gauge, check the maximum distance between the axle shaft and the cross shaft. This measurement is what is known as the end float.
- Refer to your vehicle manufacturer's service manual for the appropriate end float amount. 'C' clips may need to be substituted with others of a different thickness to achieve correct end float if too tight or too loose.
- Insert and tighten the retaining pin with a 5mm hex key.
- Reconnect the drive shaft to the differential drive flange.
- Reassemble the remainder of the differential assembly (e.g., hubs, brakes, wheels, etc.) to the vehicle according to your vehicle's service manual.

6.2.2 **B** Reinstalling Non-'C' Clip Retained Shafts

- Insert and tighten the retaining pin with a 5mm hex key.
- Reconnect the drive shaft to the differential drive flange.
- Reassemble the remainder of the differential assembly (e.g., hubs, brakes, wheels, etc.) to the vehicle according to your vehicle's service manual.

6 Testing & Final Assembly

6.3 Testing the Air Locker Actuation

To test that your air system, electrical system, and your *Air Locker* differential is functioning correctly:

- Support the vehicle such that the wheels are free to rotate (e.g., on axle stands, a chassis hoist, etc.)
- Leave the parking brake off, the transmission in neutral, and the *Air Locker* switch 'OFF'.
- Turn the ignition to the 'ON' position (leaving the motor off). The large illuminating symbol on the *Air Locker* switch cover should be 'OFF'.
- Turn the compressor (or alternate air source) on to charge the air supply up to its maximum pressure.
- While supporting the drive shaft flange, rotate one wheel by hand.
- The wheel should rotate freely and the opposite wheel should be turning in the opposite direction without any resistance or mechanical noise from within the differential.
- Turn the *Air Locker* switch to the 'ON' position. The illuminated symbol on the switch cover should light up.
- Rotate the same wheel again.
- Both wheels should rotate together.
- Turn the switch off again.
- Rotate the same wheel.
- The wheels should again rotate in opposite directions.

6.4 Re-Sealing & Filling the Differential

NOTE : Consult the *ARB Air Locker Operating & Service Manual* for recommendations on differential lubricant specifications.

- Replace the differential cover using gasket sealant or a new standard differential cover gasket for your make of vehicle.
- Refill the differential until level with the filler hole.
- Rotate the differential center 2 full turns.
- Check the oil level and add oil if necessary.
- Replace filler plug (apply thread sealant to filler plug before inserting if it is a threaded type plug).
- Wipe differential housing clean of any oil or grease which may collect dirt or other abrasive particles.

6 Testing & Final Assembly

6.5 Post-Installation Check List

Now that the *Air Locker* installation has been completed, ARB recommends that you take the time to complete the following check list just to insure that you haven't missed any of the vital steps.

- The air system has been leak tested.
- Thread locking compound was used on the ring gear bolts.
- All torque settings comply with the vehicle manufacturer's specs and were set with an accurate torque wrench.
- Differential fluid complies with ARB recommendations and has been filled to the correct level.
- All air lines and wiring have been securely cable tied to resist snagging.
- Switch(es) have been securely mounted within operator reach, yet well away from danger of accidental engagement.
- Switch(es) function properly and illuminate to indicate that *Air Locker(s)* are engaged.
- All operators who are to use the *Air Locker* have read, and fully understand the *ARB Air Locker Operating & Service Manual*.
- The *Air Locker* Warning Sticker has been located within close proximity of the actuator switch(es).

INSTALLATION PERFORMED BY:

DATE OF INSTALLATION:

ODOMETER READING:

ARB AIR LOCKER SERIAL No:



7 Parts List

RD102

Dana 35,27 SPL,3.54 & UP

7.1 Exploded Assembly Diagram (See itemized parts list overleaf)

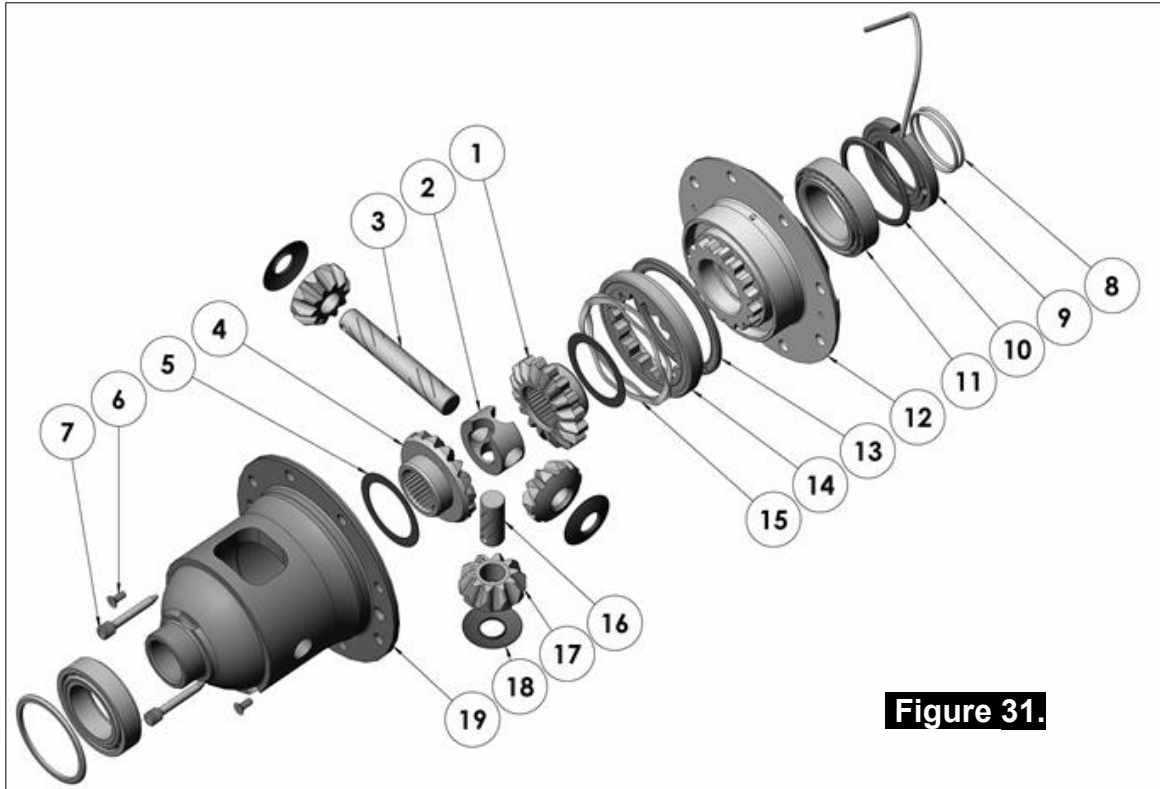

Figure 31.

7.2 Specifications

Axle Spline	27 tooth, Ø29.5mm [1.16"]
Ratio Supported	3.54:1 & up
Ring Gear ID	120.7mm [4.75"]
Ring Gear OD	193mm [7.6"]
Ring Gear Bolts	8 bolts on Ø146mm [5.75"]
Ring Gear Torque	75Nm [55 ft-lb]
Backlash	0.15-0.25mm [0.006-0.010"]
Bearing Cap Torque	75Nm [55 ft-lb]

7 Parts List

7.3 Itemized Parts List

(See exploded diagram figure 31.)

ITEM #	QTY	DESCRIPTION	PART #	NOTES
01	1	SPLINED SIDE GEAR	SEE NOTE	3
02	1	SPIDER BLOCK	070801SP	
03	1	LONG CROSS SHAFT	061302SP	
04	1	SIDE GEAR	SEE NOTE	3
05	2	SIDE GEAR THRUST WASHER	SEE NOTE	4
06	1	COUNTERSUNK SCREW (PK OF 2)	200213SP	
07	2	RETAINING PIN SET (PK OF 4)	120601SP	
08	1	SEAL HOUSING O-RINGS (PK OF 2)	160235-2	1
09	1	SEAL HOUSING KIT	081801SP	
10	2	SHIM KIT	SHK003	
*	2	MASTER SHIM	150325	
11	2	TAPERED ROLLER BEARING	160109	2
12	1	FLANGE CAP KIT	028504SP	
13	1	BONDED SEAL	160701SP	
14	1	CLUTCH GEAR & WAVESPRING KIT	050903SP	
15	1	WAVESPRING	150702SP	
16	1	SHORT CROSS SHAFT	061402SP	
17	3	PINION GEAR	SEE NOTE	3
18	3	PINION THRUST WASHER	SEE NOTE	4
19	1	DIFFERENTIAL CASE	013104SP	
*	1	BULKHEAD FITTING KIT (BANJO TYPE)	170114	5
*	1	AIR LINE (6mm DIA X 6m LONG)	170314SP	5
*	1	SOLENOID VALVE (12V)	180103	
*	1	SWITCH RR LOCKER	180224SP	
*	1	CABLE TIE (PK OF 25)	180305	
*	1	OPERATING & SERVICE MANUAL	210200	
*	1	INSTALLATION GUIDE	2102102	

* *Not illustrated in exploded view*

NOTES

- 1 For replacement O-rings use only BS133 Viton 75.
- 2 For replacement bearing use Timken part # LM102949 / LM102910.
- 3 Available only as complete 5 gear set #728J011C
- 4 Available only as complete thrust washer kit #730J01
- 5 All diffs produced before serial #17070001 came with 5mm air connection system. For information contact ARB.
- For ratios of 3.31:1 and down refer to RD103 ([Section 2.103](#)).
- Newer OEM Dana 35 ring and pinion sets use 7/16" bolts. The flange holes of the Air Locker must be reamed from Ø3/8" to Ø7/16" to suit.
- Some OEM Dana 35 drive pinion gears extend too far into the centre and converge with the differential carrier. Refer to ring and pinion modification note ([Section 5.6](#)) for correction.

Part No. 2102102
Revision 11/07/2025
Copyright © 2015 by ARB Corporation Limited

