



RD119

FORD 9", 31 SPLINE

**AIR OPERATED
LOCKING DIFFERENTIAL
INSTALLATION GUIDE**

No liability is assumed for damages resulting in the use of the information contained herein.
ARB Air Locker Air Operated Locking Differentials and Air Locker are trademarks of ARB Corporation Limited.
Other product names used herein are for identification purposes only and may be trademarks of their respective owners.

ARB 4x4 ACCESSORIES

Corporate Head Office

**42-44 Garden St
Kilsyth, Victoria
AUSTRALIA
3137**

Tel: +61 (3) 9761 6622

Fax: +61 (3) 9761 6807

Australian enquiries

North Central and South American enquiries

Other international enquiries

sales@arb.com.au

sales@arbusa.com

exports@arb.com.au

www.arb.com.au

Table of Contents:

1	Introduction	3
1.1	Pre-Installation Preparation	3
1.2	Tool-Kit Recommendations	4
2	Removing the Existing Differential	5
2.1	Vehicle Support	5
2.2	Differential Fluid Drain	5
2.3	Removing the Axles	6
2.4	Marking the Bearing Caps	6
2.5	Checking the Current Backlash Amount	7
2.6	Removing the Differential Carrier	8
3	Installing the Air Locker	9
3.1	Installing the Carrier Bearings	9
3.2	Re-Mounting the Ring Gear	10
3.3	Drilling and Tapping the Bulkhead Port	11
3.4	Checking for Assembly Clearance	12
3.5	Checking the Backlash	15
3.6	Assembling the Seal Housing	17
3.7	Profiling the Seal Housing Tube	19
3.8	Setting Up the Bulkhead Fitting	20
3.9	Bench Testing the Air Locker	22
3.10	Reinstalling the Differential and Axles	23
4	Installing the Air System	24
4.1	Mounting the Solenoid	24
4.2	Running & Securing the Air Line	26
4.3	Connection to the Bulkhead Fitting	27
5	Mounting & Connecting the Electrical System	29
5.1	Mounting the Actuator Switch(es)	29
5.2	Wiring the Actuator System	30
6	Testing & Final Assembly	34
6.1	Leak Testing	34
6.2	Testing the Air Locker Actuation	35
6.3	Re-Sealing & Filling the Differential	35
6.4	Post-Installation Check List	36
7	Parts List	37
7.1	Exploded Assembly Diagram	37
7.2	Specifications	37
7.3	Itemized Parts List	38



1 Introduction

IMPORTANT :

BEFORE ATTEMPTING TO DISMANTLE YOUR VEHICLE FOR THIS INSTALLATION, PLEASE READ THIS INSTALLATION GUIDE IN ITS ENTIRETY, AS WELL AS ALL APPLICABLE SECTIONS OF YOUR VEHICLE MANUFACTURER'S SERVICE MANUAL.

1.1 Pre-Installation Preparation

This booklet is to be used in conjunction with your vehicle manufacturer's service manual. ARB endeavors to account for every possible variation in vehicle model when publishing its installation guides, and guides are updated regularly as new model information becomes available, however, the rapid and globally varied release of some vehicles makes it difficult to insure that your vehicle model has been accurately accounted for. In the case of any technical discrepancies between this guide and your service manual, we strongly advise that you adhere to the specifications and techniques as documented in your service manual.

Although your *ARB Air Locker* comes complete with all the step by step instructions you will need to supplement your vehicle manufacturer's service manual and install your new differential, ARB recommends that you have your *Air Locker* installed by a trained professional. Many ARB distributors around the world have been fully instructed in *Air Locker* installations by ARB, and have gained a wealth of experience and skill from years of performing similar installations.

Once you begin this installation your vehicle will be immobile until all steps of the installation are complete. Make sure your *Air Locker* kit is the correct model for your vehicle and that it contains all of the parts listed on back cover of this booklet. Also be sure you have appropriately equipped yourself with all the necessary tools, parts, and materials to complete this installation (see section 1.2 *Tool-Kit Recommendations*), and that you have allowed for an appropriate amount of vehicle down time.

HINT :

Place a ✓ mark inside each of the symbols as you complete each step. It is very important NOT to miss any of the steps!

1 Introduction

1.2 Tool-Kit Recommendations

Below is a list of tools and supplies you may need to complete this installation. Requirements for your vehicle may vary. Please consult your vehicle service manual for additional recommendations.

1.2.1 Tools

- Standard automotive sizes (metric and/or imperial) of sockets, wrenches, Alan keys, and drills.
- A dial indicator or other suitable measuring tool for checking ring & pinion backlash.
- A standard automotive feeler gauge.
- A razor knife to cut the nylon tubing.
- An adjuster-nut wrench. (See your vehicle service manual)
- A torque wrench. (See vehicle service manual for required torque range.)
- A lubricant drain reservoir.
- A 11.2mm [7/16"] drill and 1/4" NPT tap for bulkhead fitting installation.
- An automotive bearing puller (2 jawed is recommended) or a differential carrier bearing puller.
- A bearing press or arbor press.

1.2.2 Supplies

- Thread lubricant/sealant compound for pressure fittings (e.g., LOCTITE #567 Teflon paste)
- Thread locking compound (e.g., LOCTITE #272)
- Either a replacement gasket, or gasket sealant for sealing the third member to the axle housing.
- A sufficient volume of differential oil to completely refill your housing. (see the *ARB Air Locker Operating and Service Manual* for recommended lubricants)
- A soap and water mixture to test for air leaks.

2 Removing the Existing Differential

2.1 Vehicle Support

- Safely secure the vehicle on a hoist. We recommend supporting the vehicle on a chassis hoist to keep the differential area at a convenient working height and to leave the wheels and axles free to be rotated and removed.
- Once supported off the ground, release the parking brake and leave the vehicle in neutral. Chock the wheels if necessary.

2.2 Differential Fluid Drain

HINT : This is a good time to check for metal particles in your oil, on your drain plug, or in the bottom of the housing which may indicate a worn bearing or differential component.

- Clean any loose dirt from around the differential third member flange area, the filler plug area, and the drain plug to avoid contaminating the differential cavity with abrasive particles.
- Position a fluid drain reservoir under the differential.
- Remove the drain plug and completely drain all differential oil from the housing.

IMPORTANT :

COLLISION DAMAGE OR HEAVY OFF-ROAD USE OF YOUR VEHICLE IN THE PAST MAY HAVE RESULTED IN SOME DEGREE OF BENDING IN THE AXLE HOUSING. ANY MISALIGNMENT OF THE AXLE TUBES MAY RESULT IN EXCESSIVE WEAR AND/OR FAILURE OF YOUR DIFFERENTIAL AND AXLE SHAFTS. ARB STRONGLY RECOMMENDS THAT YOU HAVE YOUR AXLE ASSEMBLY INSPECTED FOR CONCENTRICITY AND STRAIGHTNESS BEFORE INSTALLING YOUR AIR LOCKER.

2 Removing the Existing Differential

2.3 Removing the Third Member

- Disconnect the drive shaft from the pinion flange.
- Remove both of the rear wheels and brake drums/rotors according to your vehicle manufacturer's service manual.
- Slide the axle shafts outward until they are completely disengaged from the splines of the differential side gears.

NOTE : The oil seals are delicate and can be easily damaged. Support the weight of the axle shafts when drawing them out of their sockets in the housing.

- Remove the third member flange bolts.
- Completely remove the third member from the axle housing.
- Support the third member firmly in a vice or on a work bench.

2.4 Marking the Bearing Caps

- Using a pointed center punch, gently mark the bearing caps in a way that will enable you to know which cap is 'LEFT' and which cap is 'RIGHT', which way is 'UP' and which way is 'DOWN'. (Fig. 1.)

HINT : Many installers choose to make one punch mark on the left hand side of the left hand bearing cap and one similar punch mark on the housing at close proximity to the cap mark. The right hand side is then designated with two punch marks on the right hand side of the cap and two similar punch marks on the housing.



Figure 1.

2 Removing the Existing Differential

2.5 Checking the Current Backlash Amount

IMPORTANT:

This step is a precautionary measure recommended by ARB due to the fact that some after market ring and pinion sets have been manufactured to run with different backlash settings than those specified by your vehicle manufacturer. Although ARB must recommend you set backlash according to your service manual guidelines, we also advise that you compare the backlash measurements taken here to the recommended backlash settings in your vehicle service manual. Measurements found to be outside of your service manual recommendations may indicate the need to deviate from those settings in order to achieve quiet running with a good contact mark.

Refer to your vehicle service manual or your local authorized ARB installer for more information.

- Set a depth indicator on one of the ring gear teeth as in figure 2.

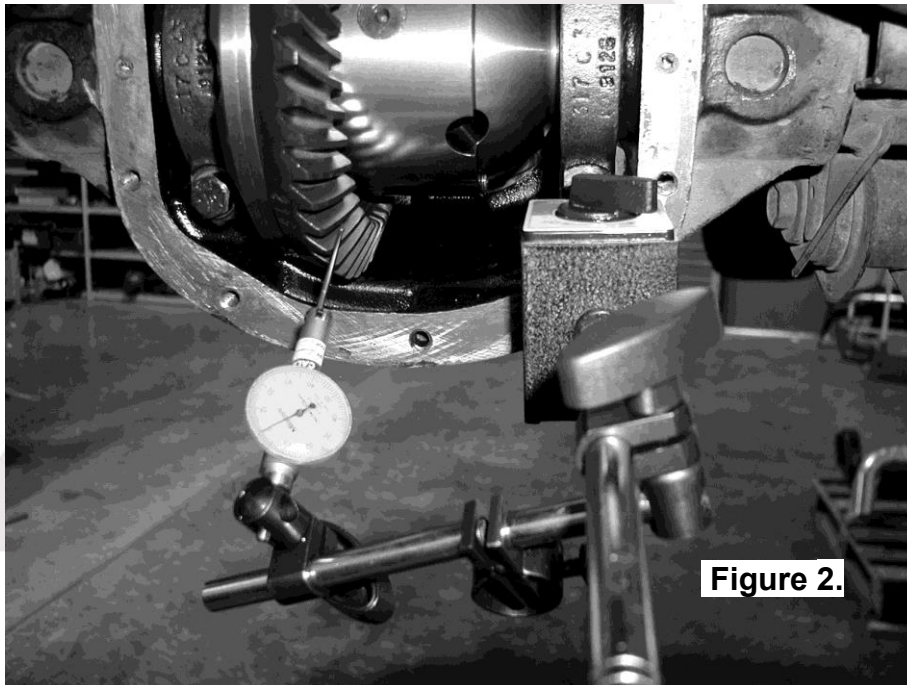

Figure 2.

- While supporting the pinion gear by holding the drive shaft flange, rotate the differential in both directions while observing the maximum variation in depth from the indicator (i.e., the highest value minus the lowest value). This value is referred to as the ring and pinion backlash.
- Rotate the differential carrier 90° and measure again for accuracy.
- Record the average of all measurements.

2 Removing the Existing Differential

2.6 Removing the Differential Carrier

- Remove both adjuster nut locking tabs.
- Loosen both bearing caps.
- Using the appropriate adjuster nut wrench, loosen the adjuster nuts at least half a turn.
- Remove the bearing caps, adjuster nuts, and tapered roller bearing cups.
- Carefully remove the differential carrier.

NOTE : The differential carrier is heavy and quite difficult to handle when covered in oil. Take care not to drop it.



3 Installing the Air Locker

3.1 Installing the Carrier Bearings

- If the tapered roller bearings from the original differential carrier are to be reused, then remove them with an automotive bearing puller and inspect them for damage and/or wear and replace them if necessary.
- Apply a thin film of high pressure grease to both bearing journals of the *Air Locker* to prevent seizing.
- Using a bearing press or arbor press, press one of the bearing cones (supplied with the *Air Locker* kit) onto one bearing journal of the *Air Locker* until the bearing seats firmly against the bearing journal shoulder.
- Invert the *Air Locker* and press the other tapered roller bearing cone onto the opposite bearing journal of the differential carrier until the bearing seats firmly against the bearing journal shoulder.



3 Installing the Air Locker

3.2 Re-Mounting the Ring Gear

- Remove the bolts that hold the ring gear in place.
- Using a plastic or copper hammer, tap in a circle around the ring gear to separate it from the original differential carrier.

NOTE : Some aftermarket ring gears use 1/2" diameter bolt threads instead of 7/16". If this is the case then the bolt holes of the *Air Locker* will require enlargement to 13mm [0.512"]. This operation should be performed by a qualified machinist.

- Apply a thin film of high pressure grease to the ring gear shoulder of the *Air Locker* to prevent seizing.
- Thoroughly clean any thread locking compound or other foreign matter from the holes of the ring gear, the threads of the ring gear bolts, and the mating surfaces between the ring gear and the *Air Locker* flange.

HINT : Stoning the ring gear mounting face before installation will remove any high spots around the threads.

- Heat the ring gear to between 80 and 100°C [175 - 212°F] in hot water or in an oven to slightly expand the gear and facilitate assembly.

NOTE : NEVER HEAT GEARS WITH A FLAME! This could damage the hardened surface of the gear and result in premature wear or failure.

- Dry the gear and bolt holes with compressed air (if wet).
- Install the ring gear onto the *Air Locker* by aligning the bolt holes and then gently tapping it around in a circle with a soft mallet. Avoid using the bolts to pull down the ring gear as this puts excess strain on the bolts and the differential flange.
- Apply a thread locking compound to the thread of each ring gear bolt before inserting it. Do not apply the compound directly into the threaded hole as this could prevent the bolt from reaching its full depth.
- Tighten the ring gear bolts in a star pattern with a torque wrench according to your vehicle manufacturer's specified torque.

3 Installing the Air Locker

3.3 Drilling and Tapping the Bulkhead Port

An airline port must be drilled and tapped through the third member casting to mount the bulkhead fitting into.

- Remove the pinion shaft assembly from the third member.
- Press the pinion support bearing out of the third member.
- Mark a spot on the third member casting in the position shown in Figure 4.

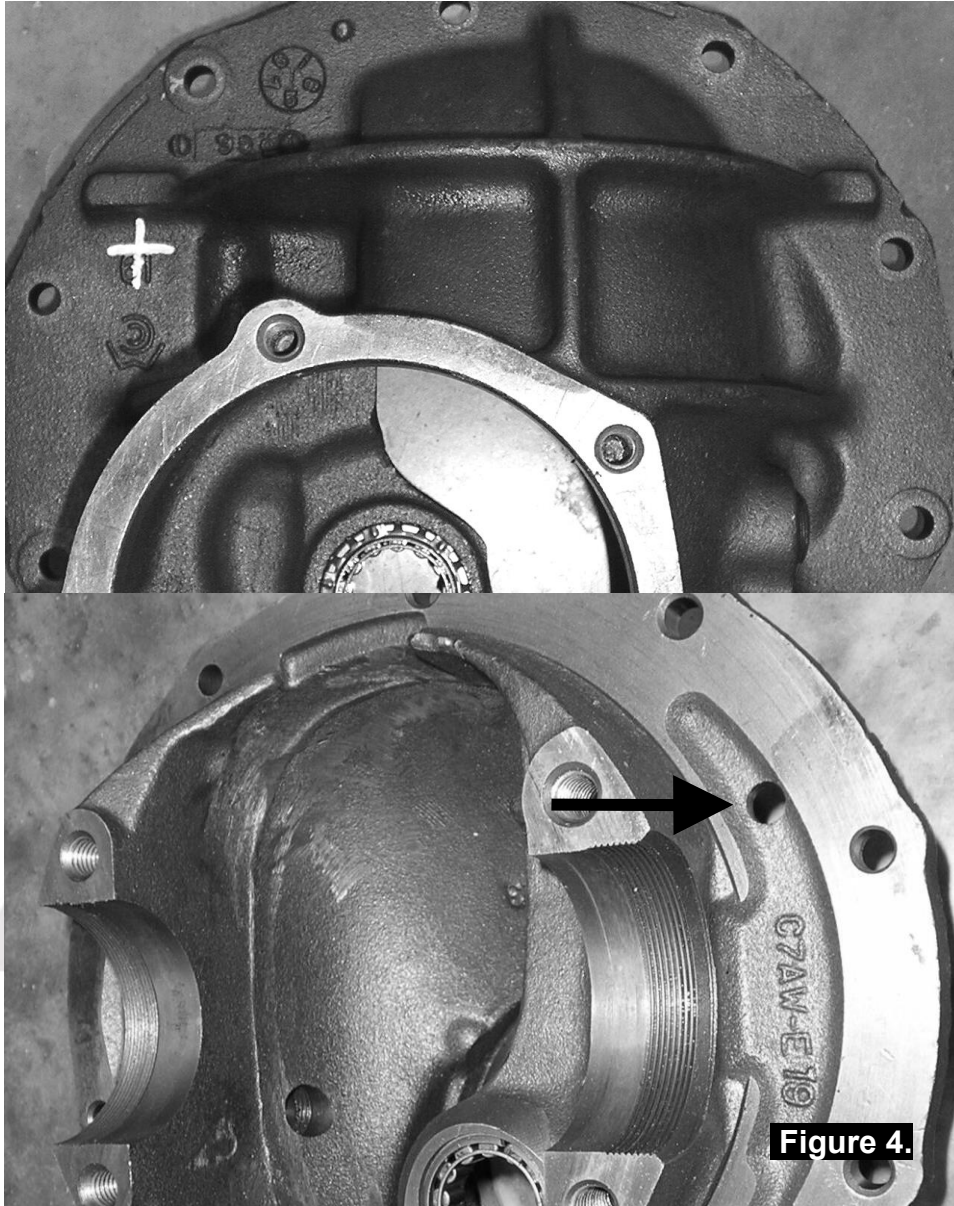

Figure 4.

- Drill through the housing square to the outside surface using a 11.2mm [7/16"] drill.
- Tap the hole from the outside using a 1/4" NPT pipe tap.
- Remove any sharp edges from the hole that may chip-off and fall into the housing.

3 Installing the Air Locker

3.4 Checking for Assembly Clearance

IMPORTANT:

Some third member castings will require modification for correct *Air Locker* installation. A properly installed *Air Locker* will have no less than 2mm [1/16"] between any part of the differential carrier and the third member casting.

- Reassemble the pinion shaft assembly using only 2 bolts finger tight. (The pinion shaft assembly will be fully assembled later)
- Hold the tapered roller bearing cups onto the cones on the carrier.
- Carefully insert the carrier assembly into the third member so that the ring gear is in mesh with the drive pinion.
- Using an automotive feeler gauge, check for adequate clearance between the body of the *Air Locker* and the third member casting around the pinion support bearing and behind the flange cap.
- If necessary, remove the pinion shaft assembly and grind or file the third member casting to gain clearance. Figure 5. shows an example of relief grinding on the corner near the pinion support bearing and along the casting flash line.

HINT : Applying a machinists marking compound to the third member casting surfaces will show any points of contact after the *Air Locker* has been removed.

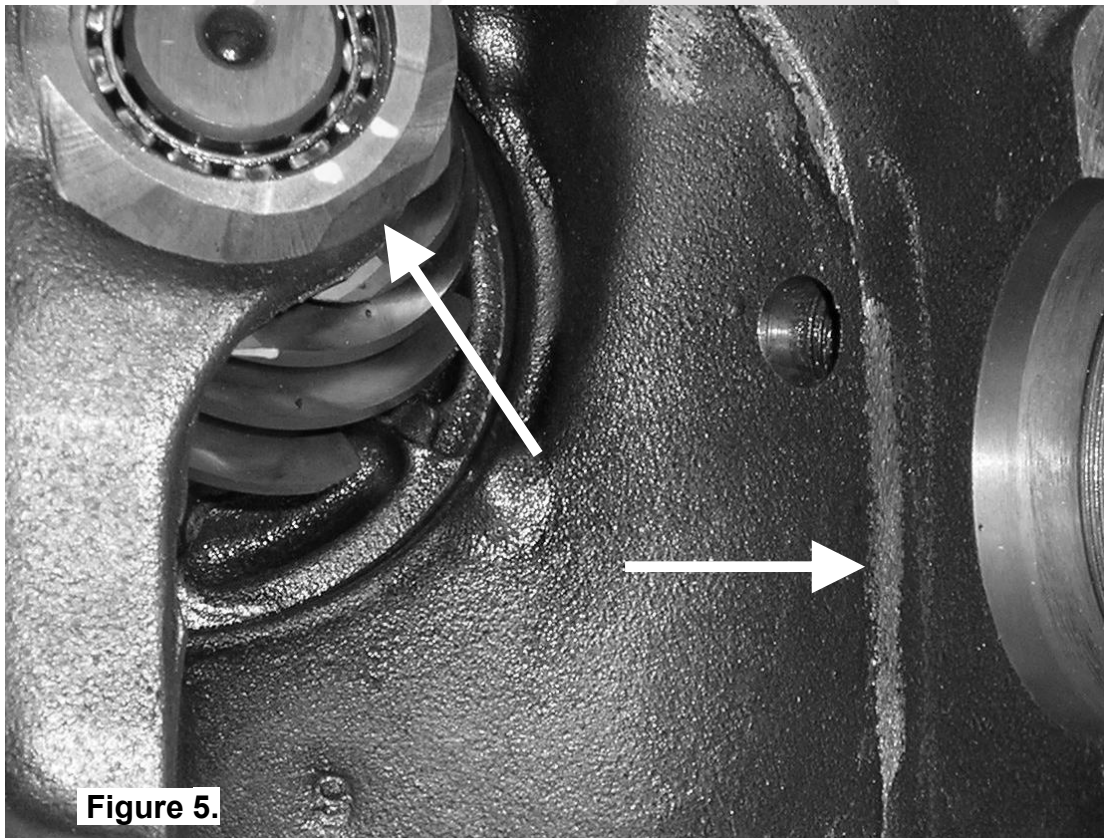
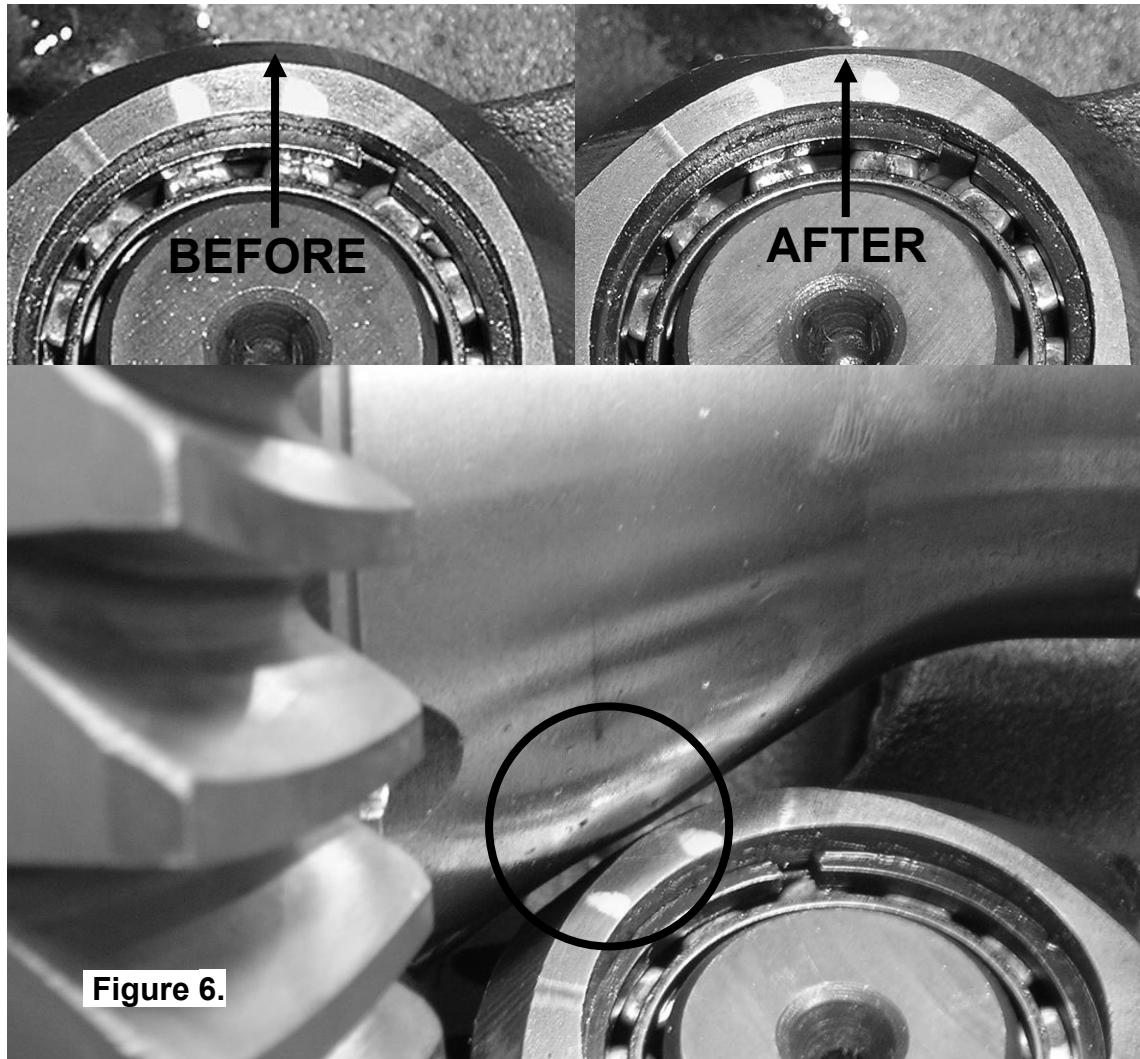

Figure 5.

3 Installing the Air Locker

- Figure 6. shows that approximately 1.5mm was ground from the housing corner near the pinion support bearing to provide 2mm of clearance for the Air Locker



- Once the required clearance has been achieved, remove the Air Locker and the pinion shaft assembly and thoroughly clean the third member of any grinding dust or other foreign particles.
- Reinstall the pinion shaft assembly and using a torque wrench tighten to the torque specified in your vehicle service manual.
- Reinstall the *Air Locker* into the third member.
- Install the bearing caps oriented as they were marked before they were removed, and finger tighten the bearing cap bolts. It is not necessary to torque them down at this time.
- Insert and lightly hand tighten the appropriate adjuster nut supplied with the *Air Locker* kit into the flange side bearing cap.

3 Installing the Air Locker

NOTE : You should feel no backlash between the ring and pinion gears once the adjuster nut tightens.

- Reverse the adjuster nut (counterclockwise) $\frac{1}{4}$ turn.
- Insert one of the original adjuster nuts into the bearing cap on the opposite side and hand tighten using the appropriate adjuster nut wrench.

NOTE : You should now feel some backlash between the ring and pinion gears. If not, there might be a clearance problem which is binding the carrier. Re-check the clearance.



3 Installing the Air Locker

3.5 Checking the Backlash

- Set a depth indicator on one of the ring gear teeth (Fig.7.).

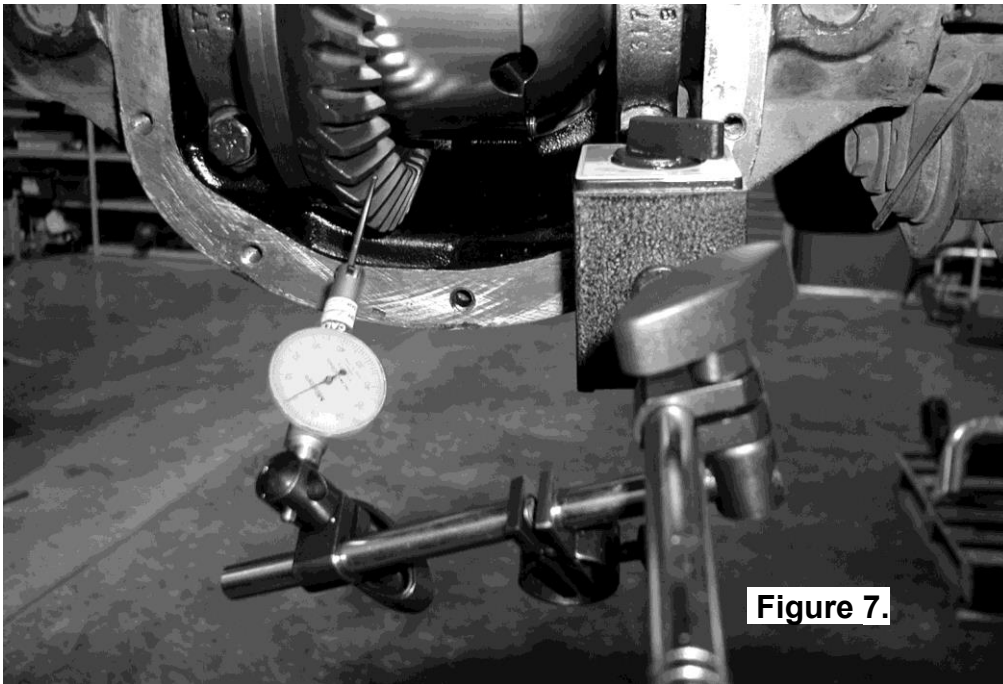

- While supporting the pinion gear by holding the drive shaft flange, rotate the differential in both directions while observing the maximum variation in depth from the indicator (i.e., the highest value minus the lowest value). This value is referred to as the ring and pinion backlash.
- Rotate the differential carrier 90° and measure again for accuracy.
- Refer to your vehicle service manual for the specified maximum and minimum amounts of backlash.

IMPORTANT:

It is critical to set up bearing pre-load when a differential is installed. Improper pre-load will result in undue bearing wear, increased stresses in the differential carrier, increased running noise, and ultimately, ring and pinion gear damage.

- Adjust the backlash and pre-load using an adjuster nut wrench to tighten or loosen the adjuster nuts as required. (Refer to your vehicle service manual.)

3 Installing the Air Locker

- Recheck backlash as before, repeating this procedure until backlash is within the specified amount.
- Tighten the bearing cap bolts with a torque wrench to the torque specified in your vehicle manufacturer's service manual.
- Before reinstalling the adjuster nut locking tabs, one of the tabs will need to be shortened as shown in 9. to avoid contacting the seal housing.



3 Installing the Air Locker

3.6 Assembling the Seal Housing

- Make sure the grooves and airway of the seal housing are clean and free from any contaminants (e.g. water, dirt, metal filings, etc.).
- Inspect the seal housing O-rings (supplied) for dirt, damage or other conditions which might cause leaks.
- Generously lubricate the O-rings with oil prior to assembly, then insert them into the grooves of the seal housing.

NOTE : When assembling the O-rings, be careful not to leave them twisted when seated in the grooves as this could cause excessive wear and leakage.

- Lubricate the seal housing running surface on the *Air Locker* carrier with oil.
- Carefully install the seal housing by sliding it all of the way onto the bearing journal with a gentle twisting motion until it sits flat against the adjuster nut.

NOTE : A twisting motion (i.e., a slight rotation while pressing the seal housing on) will allow the O-rings to engage gently and prevent them from twisting. Twisted O-rings will result in pre-mature O-ring wear and oil contamination in the air system due to the helical shape formed by the O-ring mould line.

- Rotate the seal housing until the square cutout lines up with the locking tab position at the center of the bearing cap. (Fig.8.)

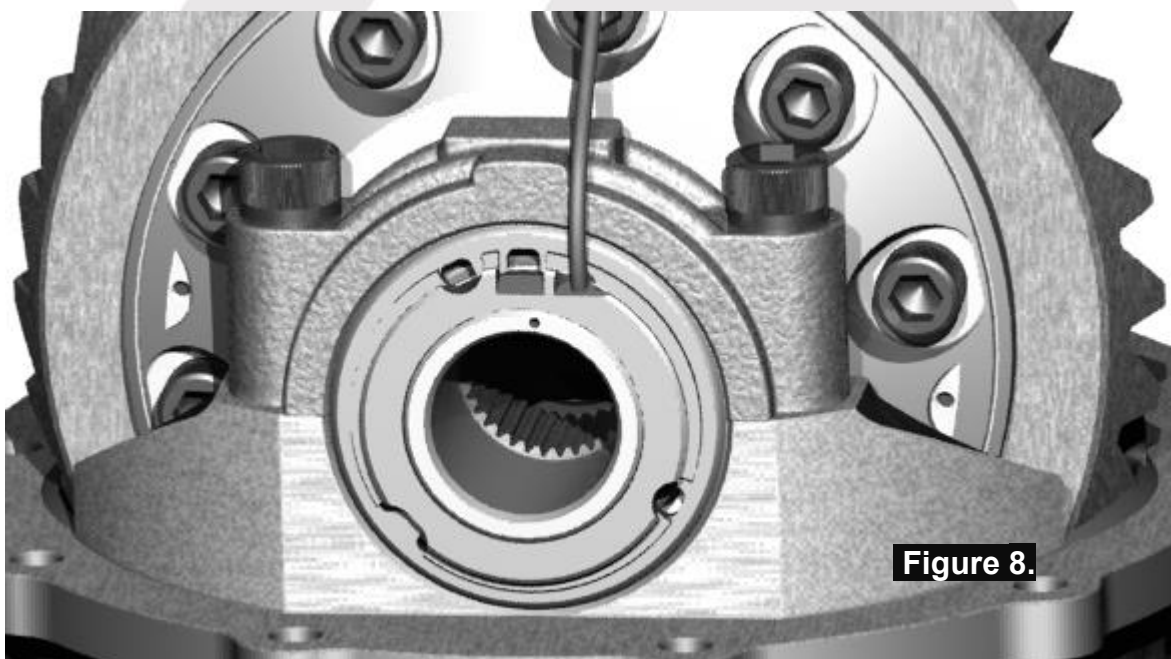
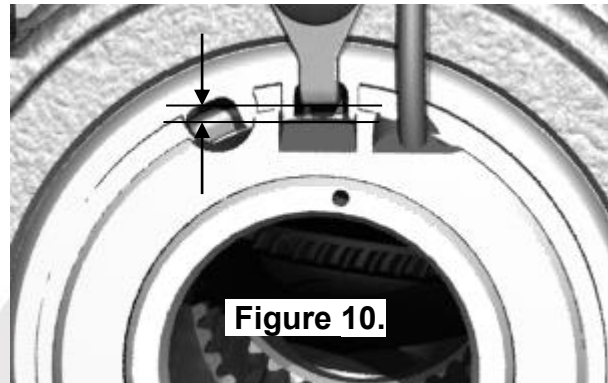
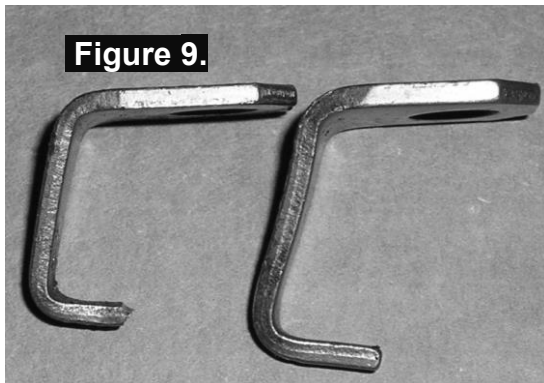

Figure 8.

3 Installing the Air Locker

- Before reinstalling the locking tabs one of the tabs will need to be shortened (see Fig. 9.) to avoid contacting the seal housing.

NOTE : There should be clearance between the locking tab and the base of the locking tab slot in the seal housing (see Fig. 10.).



- Install the spring clip by first hooking both ends of the clip into the small aligned cutouts of the seal housing and the adjuster nut, and then snapping the clip into the groove of the seal housing using a screwdriver. (Fig.11.)

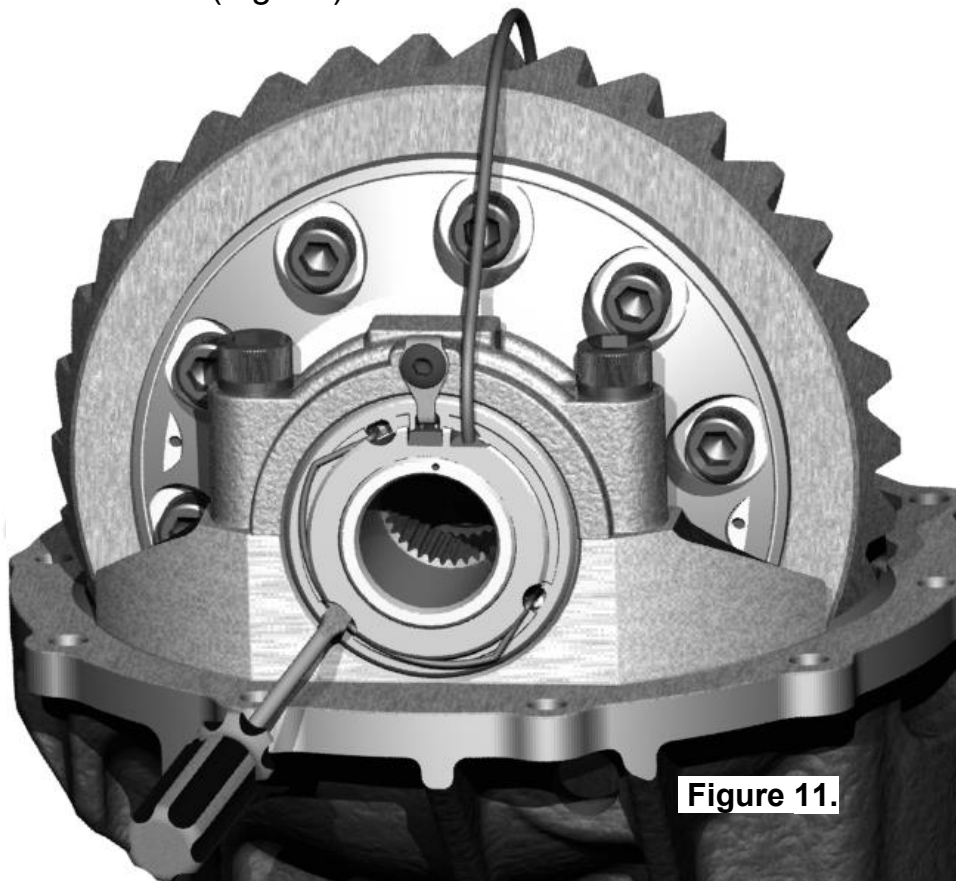

- Check that the seal housing is now secured from rotating and that it is still sitting flat against the adjuster nut.

3 Installing the Air Locker

3.7 Profiling the Seal Housing Tube

IMPORTANT:

In order for the seal housing to float and self center on the bearing journal after the tube is connected to the bulkhead fitting, the seal housing tube must not be left pulling against the seal housing. Therefore, it is critical to ensure that the tube is not under any tension. To avoid this always leave the tube long enough so that a loose hook shape can be formed between the seal housing and the bulkhead.

- Without using sharp, jagged tools such as pliers (usually your hands are the best tool for this job), gently bend the seal housing tube so that it runs closely around the outside of the differential carrier and ring gear and through the bulkhead port hole as shown in Figure 12.

NOTE : It is also a good idea to keep the tube away from the bearing caps or any other part of the differential casting as any contact due to vibration or shock may wear the tube and eventually cause a leak.

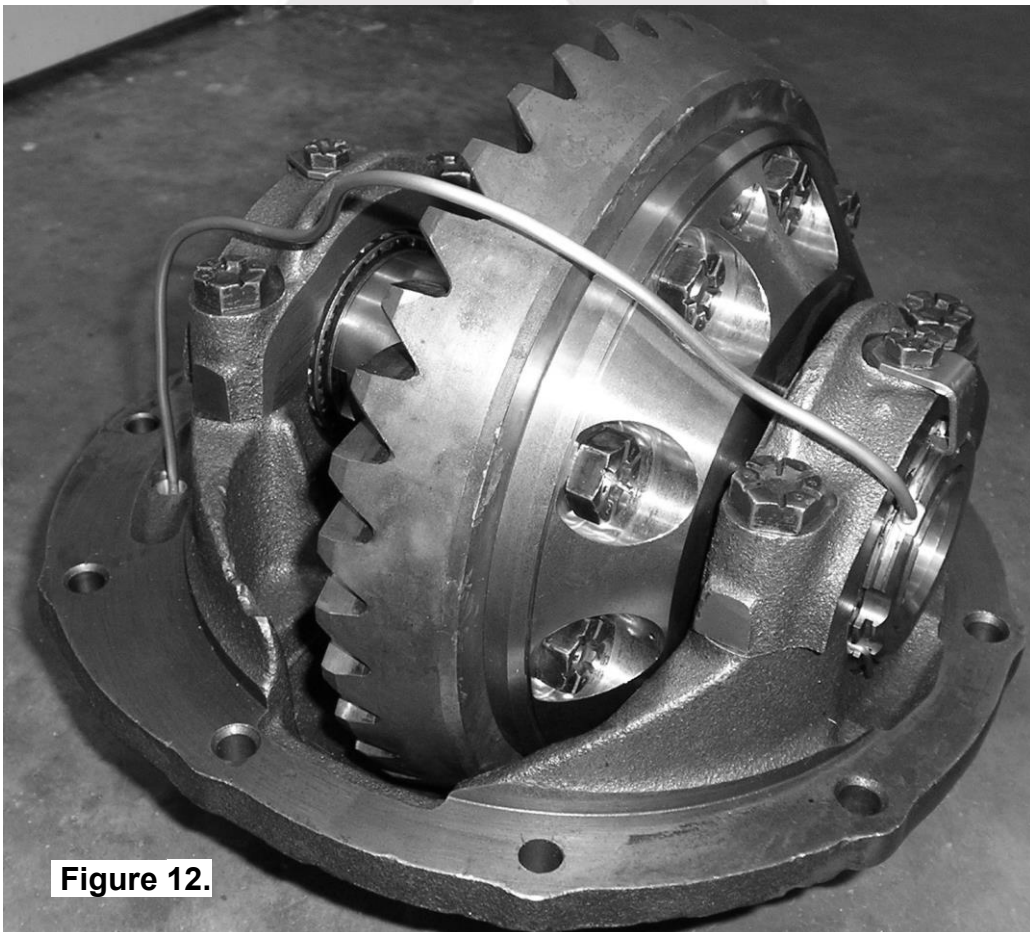

Figure 12.

3 Installing the Air Locker

3.8 Setting Up the Bulkhead Fitting

- Trim the seal housing tube that is extended through the bulkhead port to approximately 8mm [5/16"] long using an automotive brake line tubing cutter.

NOTE : Never use a hacksaw to cut the seal housing tube as this will leave metal filings in the air system.

- Apply thread sealant to the outside threads of the bulkhead body.
- Screw the bulkhead body into the tapped hole, and lightly tighten using a 14mm [9/16"] spanner.
- Wipe the area clean of any excess thread sealant (inside and outside of the housing).
- Insert the free end of the seal housing tube into the bulkhead fitting until it protrudes approximately 8mm [5/16"] through the other side.
- From the outside of the housing, assemble one of the small O-rings over the top of the short length of seal housing tube protruding through the bulkhead fitting.
- Install the brass spacer.
- Install the second small O-ring after the spacer.
- While holding the seal housing tube into the bulkhead fitting, insert the chamfered end of the center compression nut over the extended tube as shown in the assembly diagram (Fig. 13.), and screw it into the bulkhead body, and tighten using Pozidriv #3 screwdriver.

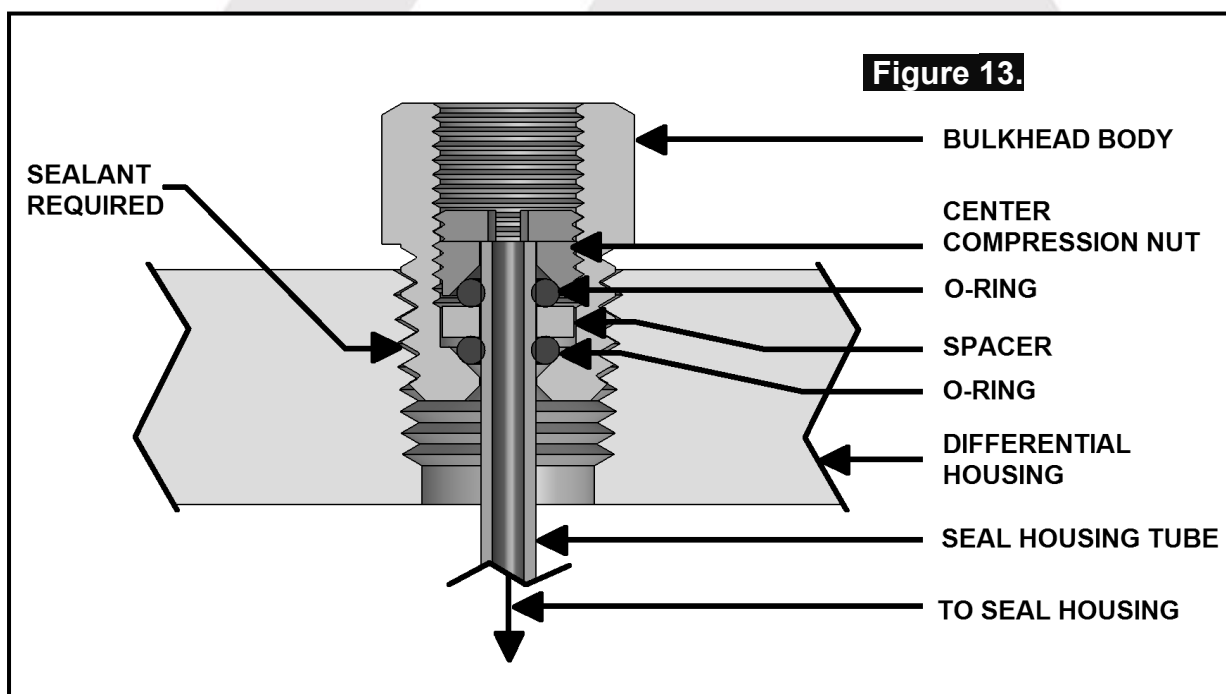

3 Installing the Air Locker

OTE : Make sure the seal housing tube is all of the way into the center compression nut while you are tightening it.

NOTE : Firmly tighten the center compression nut so that a good seal is formed around the tube.



3 Installing the Air Locker

3.9 Bench Testing the Air Locker

- To test the *Air Locker*, when 620kPa [90 PSI] shop air is applied to the seal housing tube, the *Air Locker* should engage.
- Check all fittings and the seal housing for air leaks.
- Rotate the differential carrier by turning the pinion flange whilst applying air pressure.

NOTE : An accurate way to test for air leaks is to fit a shut-off valve to an air pressure gauge (ARB part # ALTG01 shown in Fig.14.). Once 620 KPA [90 PSI] is reached shut the valve off, disconnect the air hose, and watch to see if there is any drop in pressure. Any pressure drop will indicate an air leak.

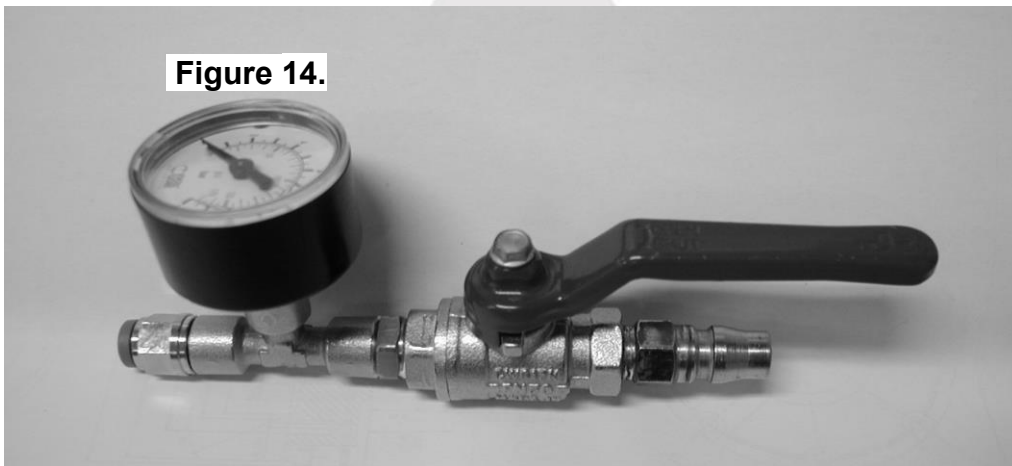

- If a leak is found to be present, spray a soap and water mixture onto the bulkhead air fitting. Bubbles should appear at any leak points.

NOTE : Do not spray this soapy mixture inside the differential.

- Check that leaky fittings have been adequately tightened.
- Disassemble, clean threads, and reapply thread sealant if leaking persists.
- If a leak is found at the seal housing, carefully remove and refit. Be very careful with the O-rings and check they have not been damaged during installation.

3 Installing the Air Locker

3.10 Reinstalling the Differential and Axles

- Reinstall the third member to the differential housing according to your vehicle service manual.
- Reconnect the drive shaft.
- Inspect the condition of the axle seals and replace if necessary.
- Insert both axles fully into the housing, engaging splines, and then gently tap them inward.

NOTE : Be careful not to damage the axle shaft oil seals when installing the axle. Support the axle's entire weight where possible.

- Torque down the axle bolts to manufactures specifications.

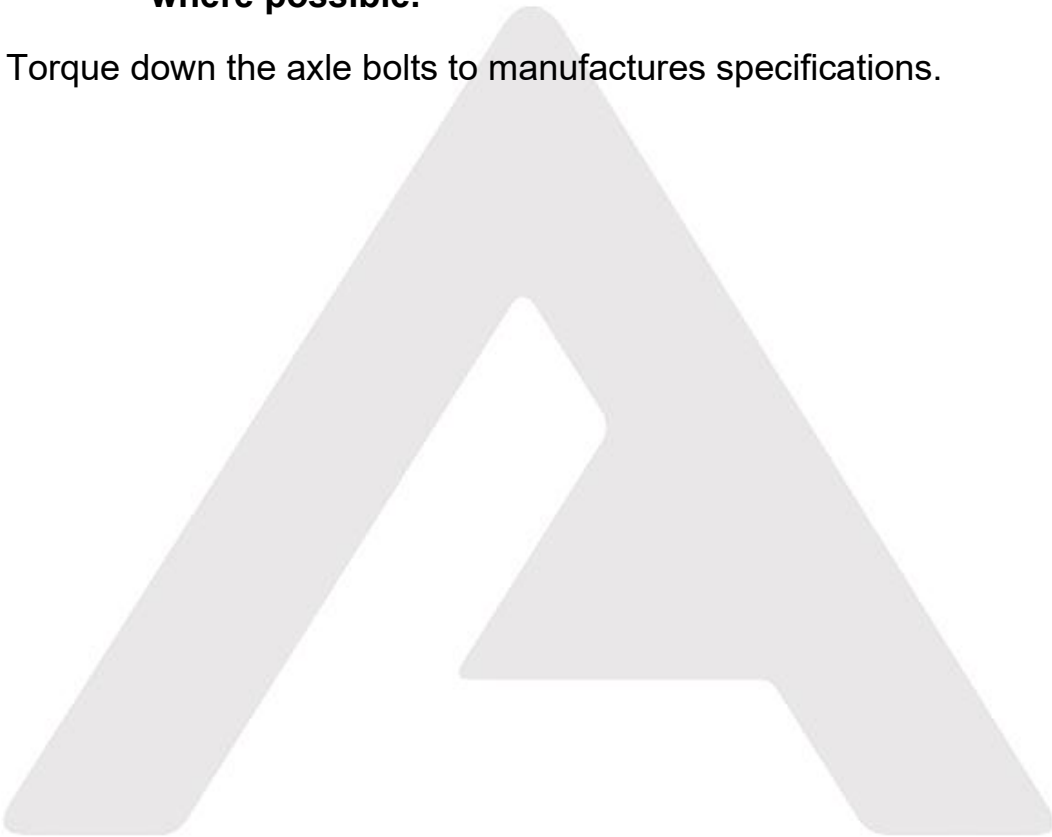

4 Installing the Air System

4.1 Mounting the Solenoid

4.1.1 Connection to an ARB Air Compressor (Fig.15.)

- Remove one of the 1/8" BSP plugs from its port in the compressor tank.
- Apply Teflon paste to the 1/8" BSP nipple on the solenoid and insert it into the port and tighten. The solenoid should be rotated into a position which does not obstruct any other ports on the compressor tank.

NOTE : The coil and stem of the solenoid can be removed to make installation easier.

NOTE : The solenoid is marked with two #1 ports. If space is tight, a second solenoid can be "daisy-chained" off the first one by removing the plug from the redundant #1 port and screwing the nipple from the second solenoid into it (Fig. 15.).

NOTE : The solenoid exhausts compressed air through the center of the black retaining cap when the *Air Locker* is disengaged. Make sure this orifice cannot be obstructed.

- Assemble the 6mm push-in fitting into the solenoid outlet port (stamped "2") and hand tighten.

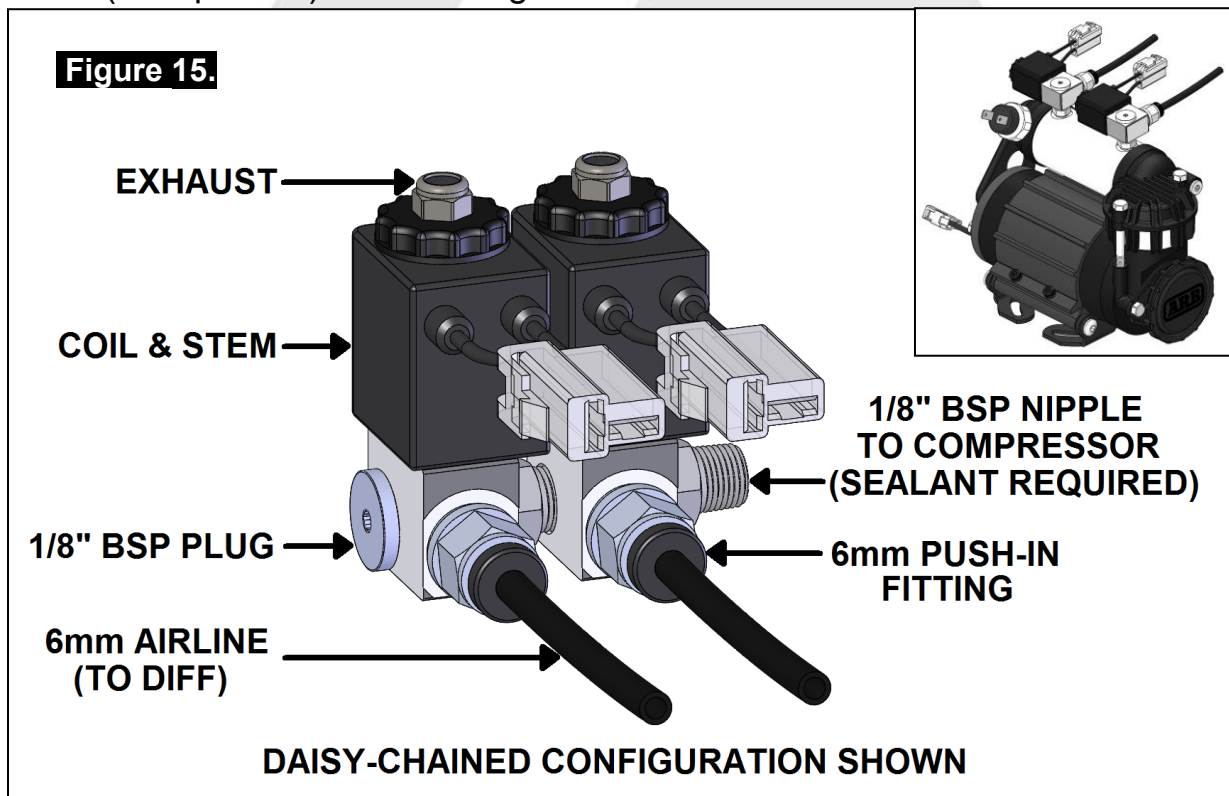

4 Installing the Air System

4.1.2 Connection to an Alternate Air Source

For ease of installation, quality of air supply, and a high level of dependability from your *Air Locker(s)*, ARB strongly recommends use of a genuine ARB Air Compressor, however, the *Air Locker* air system can be operated on any alternate air source that meets each of the following guidelines:

- Must supply a minimum of 85PSI [586kPa].
- The Air source should have a tank capacity that enables it to actuate the *Air Locker(s)* in one charge so that no hesitation is experienced when locking one or two differentials.

HINT : A good way to insure that you have the necessary capacity is to make sure you can engage, disengage, and then reengage your *Air Locker(s)* without the air source having to regenerate (e.g., without the compressor turning on to refill the tank).

- Must supply clean air, free of rust, dirt, water, or other foreign matter.
- Must match the 1/8" BSP porting of the *Air Locker* solenoid.
- Mount solenoid within close proximity of the air supply and secure it from the effects of vibration and shock.
- Connect the air supply to the 1/8" BSP inlet port of the solenoid (stamped "1" on the solenoid body) using thread sealant.

IMPORTANT :

ARB cannot warrant your *Air Locker(s)* against damage caused as a result of using an alternate air supply. If you have any doubts as to the suitability of your air system to use in an *Air Locker* system, consult your ARB distributor.

4 Installing the Air System

4.2 Running and Securing the Air Line

The path taken by the air line from your air source (i.e., compressor) to your *Air Locker* is unique to your vehicle and the position of your air source. Plan ahead carefully when running the air line and always follow these guidelines:

- Account for axle travel when running the line from the axle to a fixed point on the vehicle. Leave enough slack in the air line to allow for maximum suspension travel in both directions.
(Not necessary on IFS installations)
- Avoid leaving large lengths of air line hanging underneath the vehicle where they may get tangled on rocks, sticks, etc.

HINT : **Cable tying the air line to one of your flexible brake lines will account for axle travel and should help keep your line from getting snagged.**

- Run the air line all the way from the compressor to the differential before trimming either end of the line to length. This will save complications that may arise if the air line has to be removed.
- Make sure the line does not contact sharp edges or abrasive surfaces that may damage the air line over time.
- Do not run the air line around tight bends which may kink the air line and restrict or block the air flow.
- Keep the air line well away from your vehicle's exhaust components. Air lines will melt if subjected to extreme heat.
- Do not run more air line than necessary. Excess line volume created when coiling the left over hose, using unusually large diameter hose, etc., will increase drain on the compressor tank resulting in the compressor running more often than needed.
- Support the air line by tying it back with cable ties wherever possible.
- At the solenoid end of the air line, always trim the line to length with a sharp knife to avoid distorting the tube where it plugs into the push-in fitting.

NOTE : **To remove the air line from the push-in fitting; push the air line into the fitting as far as possible, then press the flange inward, then pull the air line free of the fitting.**

4 Installing the Air System

- To attach the air line to the push-in fitting of the solenoid; insert the line firmly into the fitting, pull outward on the flange of the fitting while holding the line as far into the fitting as possible, and then gently pull outward on the air line to clamp the line in place.

4.3 Connection to the Bulkhead Fitting

- In the case of an IFS axle assembly or in the case that the axle assembly has been completely removed from the vehicle, the assembly will have to be remounted in order to position the bulkhead fitting in its correct location for air line access.
 - Trim the air line to length using a sharp knife.
 - Assemble an aluminium washer onto the banjo bolt and insert through the banjo fitting. Assemble second aluminium washer and tighten into bulkhead fitting using a 14mm [9/16"] spanner. (Fig.16.)
 - Apply thread sealant to the tapered thread of the compression fitting body and screw into the banjo fitting. Tighten using a 12mm spanner.
 - Insert the outer compression nut and ferrule over the air line.
- Ferrule should be orientated as per Fig.16.

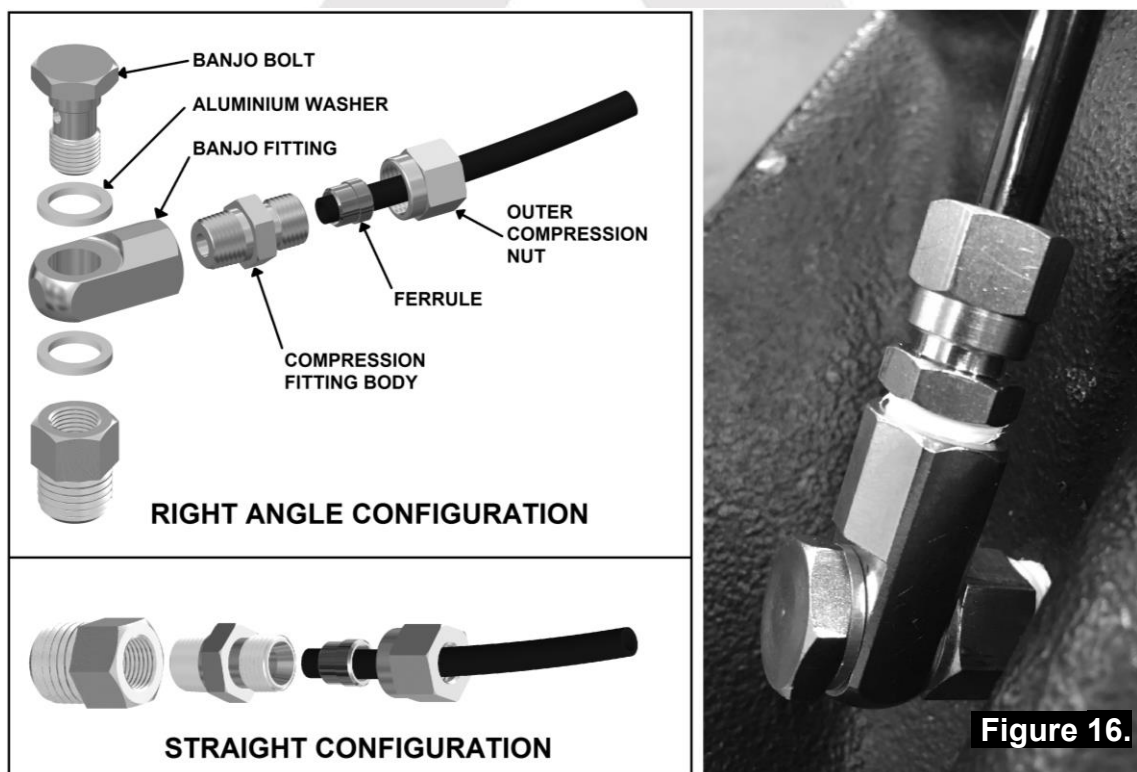

4 Installing the Air System

- Push the airline into the compression fitting body and screw the outer nut down onto it. Using a 12mm spanner, tighten the outer nut onto the compression fitting body.

NOTE : Some force is required to crush the ferrule, however the outer compression nut will tighten against a stop. Over tightening will not create a better seal.

- Secure any loose sections of tube with a cable tie.

NOTE : When right angle routing of the tube is not required, screw the compression fitting body straight into the bulkhead fitting body (Fig.16.).



5 Mounting & Connecting the Electrical System

5.1 Mounting the Actuator Switch(es)

Air Locker actuator switch(es) can be easily panel mounted inside the vehicle in a 21mm x 36.5mm [0.83" x 1.44"] rectangular cutout.

NOTE : Only attach the cover plate to the face of the switch once the switch has been mounted and wired correctly as the cover plates are designed to be difficult to remove.

For reasons of safety and for ease of operation, the *Air Locker* actuator switch(es) should be mounted in a location picked to best suit the operator. Make sure you have taken the following points into consideration:

- Switch(es) MUST be mounted and should never be allowed to simply dangle from the wiring loom during vehicle use.
- Switch(es) should be within easy reach of the driver. Ideally, any *Air Locker* switch should be able to be operated without physical effort or distraction to the driver.
- Switch(es) should be mounted within the line of sight of the driver so that switch position ('ON' or 'OFF') can be visually determined by the rocker position and the illumination state.
- The position of the switch(es) should best eliminate any possibility of accidental operation by the driver or one of the passengers.
- Switch cutout position(s) must be located in an area with a minimum of 50mm [2"] of clearance behind the face of the cutout.
- Switch(es) should not be mounted where they will be exposed to water (e.g., in the lower section of an inner door panel).
- ARB recommends that you apply the *Air Locker* Warning Sticker (ARB part # 210101) within close visual proximity of the switch location.

NOTE : If no adequate position can be found on existing dashboard panels, a surface mounted bracket (Fig. 17.) may be purchased from your ARB *Air Locker* distributor to suit 1, 2, or 3 switches.

5 Mounting & Connecting the Electrical System



5.2 Wiring the Actuator System

5.2.1 Connection to an ARB Air Compressor

When wiring the *Air Locker* actuator switch(es) and solenoid(s) to an ARB Air Compressor, all connections can easily be set up directly from the supplied wiring loom. (Fig. 18.)

NOTE : 180409 model loom shown for reference only. Refer to your ARB Air Compressor Installation Guide for details on configuring your installation.

5 Mounting & Connecting the Electrical System

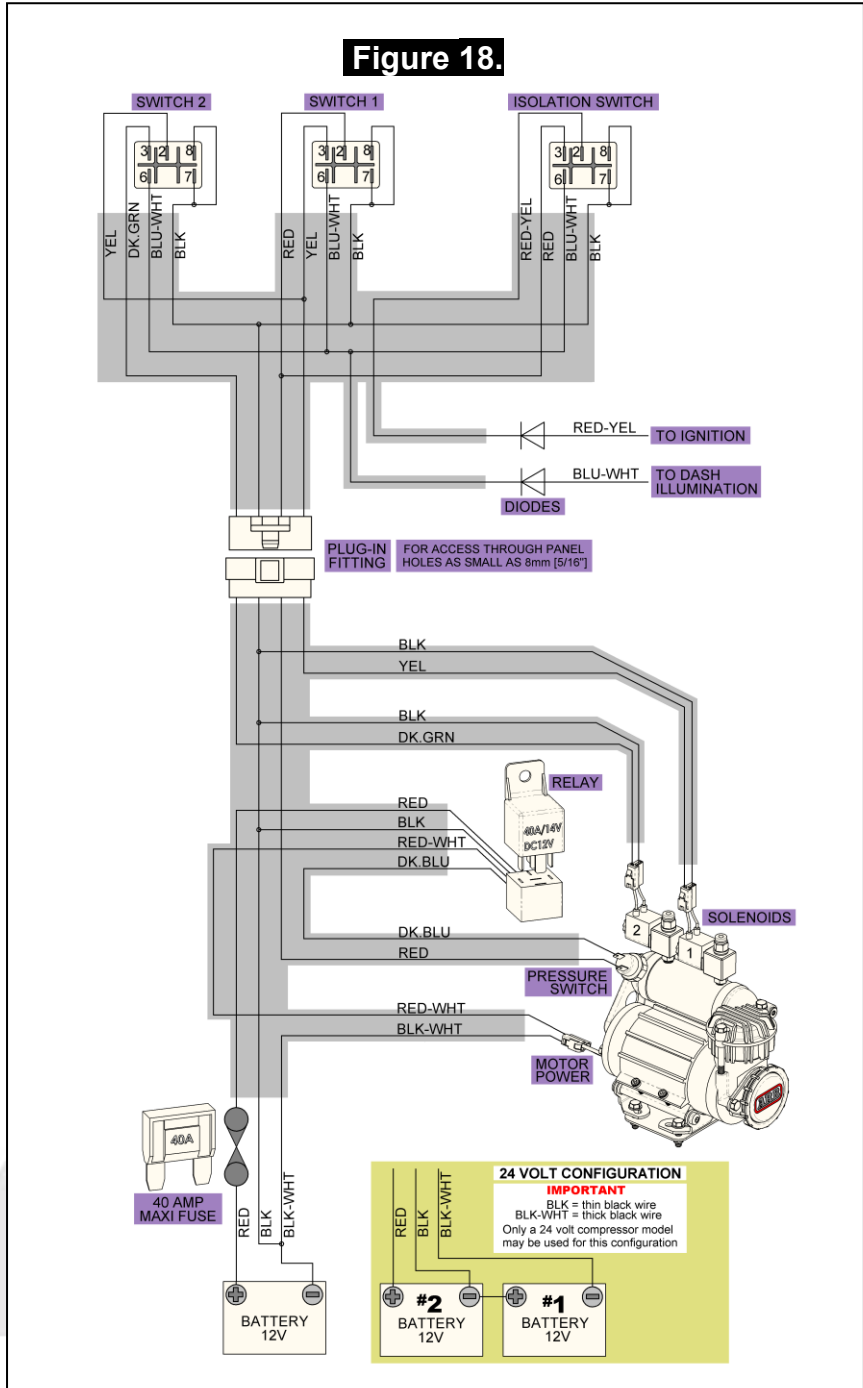

5 Mounting & Connecting the Electrical System

5.2.2 Connection to an Alternate Air Source

When connecting the actuation switch to an alternate air source, the switch(es) should be wired according to figures 20. and 21., depending on whether one or two *Air Lockers* will be installed in the vehicle.

5.2.2.1 Single Air Locker System

- If only one *Air Locker* is to be installed in the system, the switch and solenoid should be wired according to figure 20. regardless of whether the *Air Locker* has been installed in the front or rear axle of the vehicle.
- Attach the appropriate switch cover (i.e., 'FRONT' or 'REAR') to the switch.

NOTE : Refer to Figure 19. for the correct switch terminal identification and switch orientation.

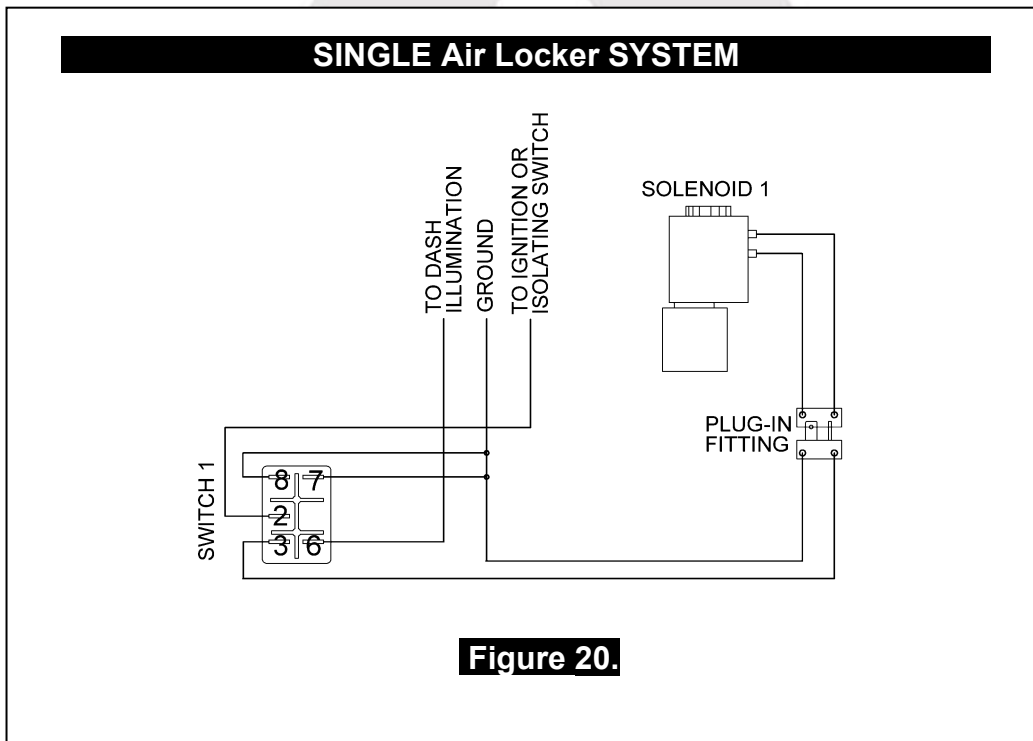

6 Testing & Final Assembly

6.1 Leak Testing

- With the vehicle parked and the engine off, turn the compressor on and wait until the air system is fully charged.

NOTE : With the *Air Locker(s)* disengaged, the air source (i.e., compressor) should not have to recharge over time. Intermittent recharging without *Air Locker* use usually indicates a leak at the solenoid fittings or at the compressor tank O-ring seal.

- Actuate the *Air Locker(s)*.
- The compressor should not come on again for a period of at least 15min. Air system recharging within that time period would indicate that a leak is present in the system.

NOTE : If an alternate air source (e.g., an air cylinder or a belt driven air pump) is used instead of a compressor, the air system will have to be leak tested with a pressure gauge and a shut-off valve in series before the solenoid input.

- If a leak is found to be present, spray a soap and water mixture onto all air fittings in the system while the compressor is fully charged. Bubbles should appear at any leak points.
- Check that leaky fittings have been adequately tightened.
- Disassemble, clean threads, and reapply thread sealant if leaking persists.

6 Testing & Final Assembly

6.2 Testing the Air Locker Actuation

To test that your air system, electrical system, and your *Air Locker* differential is functioning correctly:

- Support the vehicle such that the wheels are free to rotate (e.g., on axle stands, a chassis hoist, etc.)
- Leave the parking brake off, the transmission in neutral, and the *Air Locker* switch 'OFF'.
- Turn the ignition to the 'ON' position (leaving the motor off). The large illuminating symbol on the *Air Locker* switch cover should be 'OFF'.
- Turn the compressor (or alternate air source) on to charge the air supply up to its maximum pressure.
- While supporting the drive shaft flange, rotate one wheel by hand.
- The wheel should rotate freely and the opposite wheel should be turning in the opposite direction without any resistance or mechanical noise from within the differential.
- Turn the *Air Locker* switch to the 'ON' position. The illuminated symbol on the switch cover should light up.
- Rotate the same wheel again.
- Both wheels should rotate together.
- Turn the switch off again.
- Rotate the same wheel.
- The wheels should again rotate in opposite directions.

6.3 Re-Sealing & Filling the Differential

NOTE : Consult the *ARB Air Locker Operating & Service Manual* for recommendations on differential lubricant specifications.

- Replace the differential cover using gasket sealant or a new standard differential cover gasket for your make of vehicle.
- Refill the differential until level with the filler hole.
- Rotate the differential carrier 2 full turns.
- Check the oil level and add oil if necessary.
- Replace filler plug (apply thread sealant to filler plug before inserting if it is a threaded type plug).
- Wipe differential housing clean of any oil or grease which may collect dirt or other abrasive particles.

6 Testing & Final Assembly

6.4 Post-Installation Check List

Now that the *Air Locker* installation has been completed, ARB recommends that you take the time to complete the following check list just to insure that you haven't missed any of the vital steps.

- The air system has been leak tested.
- Thread locking compound was used on the ring gear bolts.
- All torque settings comply with the vehicle manufacturer's specs and were set with an accurate torque wrench.
- Differential fluid complies with ARB recommendations and has been filled to the correct level.
- Axle breather has been checked and found to be clear and free flowing, and located where it will not be susceptible to water or mud contamination.
- All air lines and wiring have been securely cable tied to resist snagging.
- Switch(es) have been securely mounted within operator reach, yet well away from danger of accidental engagement.
- Switch(es) function properly and illuminate to indicate that *Air Locker(s)* are engaged.
- All operators who are to use the *Air Locker* have read, and fully understand the *ARB Air Locker Operating & Service Manual*.
- The *Air Locker* Warning Sticker has been located within close proximity of the actuator switch(es).

INSTALLATION PERFORMED BY: _____

DATE OF INSTALLATION: _____

ODOMETER READING: _____

ARB AIR LOCKER SERIAL No: _____



7 Parts List

RD119

Ford 9",31 SPL

7.1 Exploded Assembly Diagram (See itemized parts list overleaf)

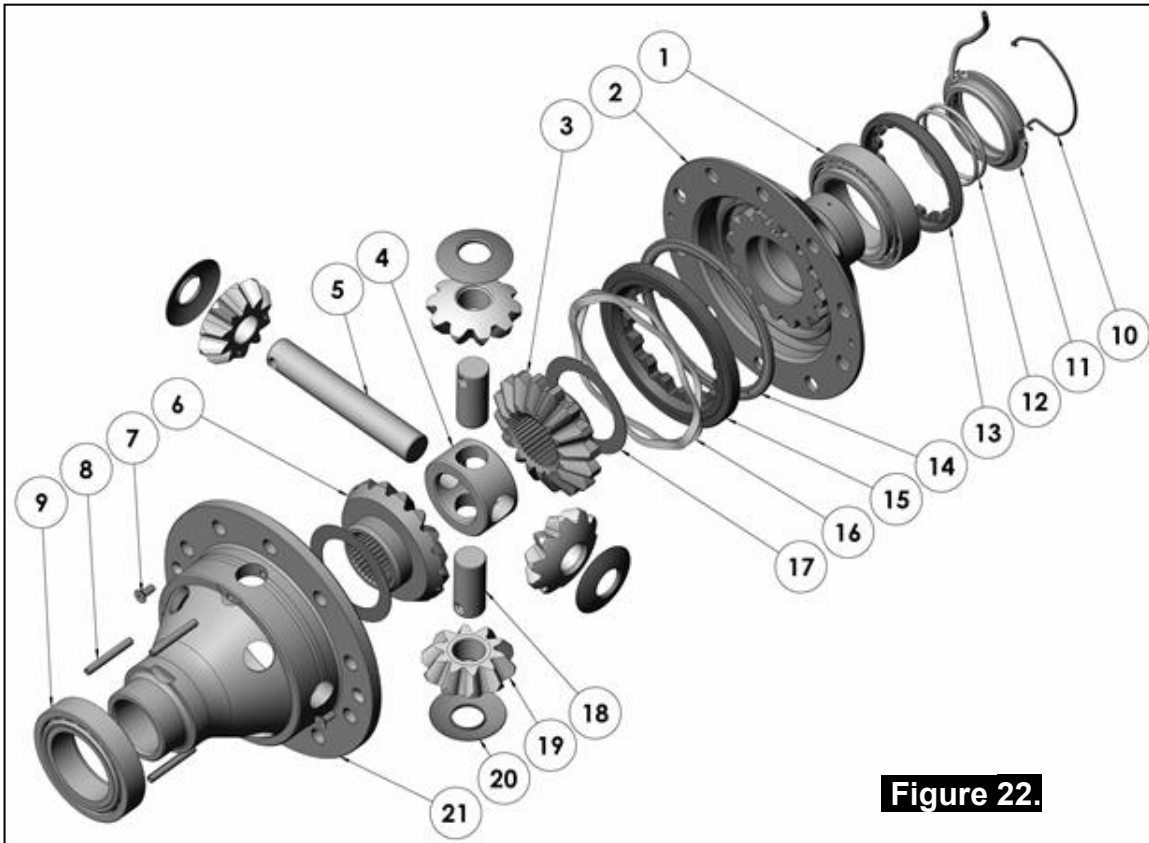

7.2 Specifications

Axle Spline	31 tooth, Ø33.5mm [1.32"]
Ratio Supported	All
Ring Gear ID	127.0mm [5.00"]
Ring Gear OD	229mm [9"]
Ring Gear Bolts	10 bolts on Ø152mm [6.00"]
Ring Gear Torque	95Nm [70 ft-lb]
OEM Backlash	0.25-0.41mm [0.010-0.016"]
Non-OEM Backlash	0.18-0.25mm [0.007-0.010"]
Bearing Cap Torque	81Nm [60 ft-lb]

7 Parts List

7.3 Itemized Parts List

(See exploded diagram figure 22.)

ITEM #	QTY	DESCRIPTION	PART #	NOTES
01	1	TAPERED ROLLER BEARING	NOT SUPPLIED	
02	1	FLANGE CAP KIT	027306SP	
03	1	SPLINED SIDE GEAR	SEE NOTE	2
04	1	SPIDER BLOCK	070201SP	
05	1	LONG CROSS SHAFT	060204SP	
06	1	SIDE GEAR	SEE NOTE	2
07	1	COUNTERSUNK SCREW (PK OF 2)	200213SP	
08	1	RETAINING PIN SET (PK OF 4)	120701SP	
09	1	TAPERED ROLLER BEARING	NOT SUPPLIED	
10	1	SEAL HOUSING RETAINING CLIP	150602SP	
11	1	SEAL HOUSING KIT	082002SP	
12	1	SEAL HOUSING O-RINGS (PK OF 2)	160235-2	1
13	1	ADJUSTER NUT (75.3mm [2.95"])	100703SP	
*	1	ADJUSTER NUT (80mm [3.15"])	100704SP	
14	1	BONDED SEAL	160703SP	
15	1	CLUTCH GEAR & WAVESPRING KIT	050904SP	
16	1	WAVESPRING	150704SP	
17	2	SIDE GEAR THRUST WASHER	SEE NOTE	3
18	2	SHORT CROSS SHAFT	060403SP	
19	4	PINION GEAR	SEE NOTE	2
20	4	PINION THRUST WASHER	SEE NOTE	3
21	1	DIFFERENTIAL CASE	012206SP	
*	1	BULKHEAD FITTING KIT (BANJO TYPE)	170114	4
*	1	AIR LINE (6mm DIA X 6m LONG)	170314SP	4
*	1	SOLENOID VALVE (12V)	180103	
*	1	SWITCH FR OR RR LOCKER	180225SP	
*	1	CABLE TIE (PK OF 25)	180305	
*	1	OPERATING & SERVICE MANUAL	210200	
*	1	INSTALLATION GUIDE	2102119	

* *Not illustrated in exploded view*

NOTES

- 1 For replacement O-rings use only BS132 Viton 75.
- 2 Available only as complete 6 gear set #728H091
For the 35 spline Ford 9" refer to RD99 ([Section 2.99](#)).
Refer to seal housing set-up tech note ([Section 5.2](#)).
- 3 Available only as complete thrust washer kit #730H01
- 4 All diffs produced before serial #17070001 came with 5mm air connection system.
For information contact ARB.

Part No. 2102119
Revision 11/07/2025
Copyright © 2013 by ARB Corporation Limited

