



# RD180

**NISSAN R180A, 27 SPLINE,  
3.69 & UP**

---

**AIR OPERATED  
LOCKING DIFFERENTIAL  
INSTALLATION GUIDE**

---

No liability is assumed for damages resulting in the use of the information contained herein.  
*ARB AIR LOCKER* Locking Differentials and *AIR LOCKER* are trademarks of ARB Corporation Limited.  
Other product names used herein are for identification purposes only and may be trademarks of their respective owners.



---

# **ARB 4x4 ACCESSORIES**

**Corporate Head Office**

**42-44 Garden St  
Kilsyth, Victoria  
AUSTRALIA  
3137**

**Tel: +61 (3) 9761 6622**

**Fax: +61 (3) 9761 6807**

**Australian enquiries**

**North and South American enquiries**

**Other international enquiries**

**[sales@arb.com.au](mailto:sales@arb.com.au)**

**[sales@arbusa.com](mailto:sales@arbusa.com)**

**[exports@arb.com.au](mailto:exports@arb.com.au)**

---

**[www.arb.com.au](http://www.arb.com.au)**

## Table of Contents:

<b>1</b>	<b>Introduction</b>	<b>3</b>
1.1	Pre-Installation Preparation	3
1.2	Tool-Kit Recommendations	4
<b>2</b>	<b>Removing the Existing Differential</b>	<b>5</b>
2.1	Vehicle Support	5
2.2	Differential Fluid Drain	5
2.3	Removing the Axles & Differential	5
2.4	Marking the Bearing Caps	6
2.5	Checking the Current Backlash Amount	6
2.6	Removing the Differential Carrier	7
<b>3</b>	<b>Bench Measurement</b>	<b>8</b>
3.1	Approximate Backlash Shimming	8
3.2	Calculation & Selection of Shims	9
<b>4</b>	<b>Installing the Air Locker</b>	<b>11</b>
4.1	Installing the Carrier Bearings	11
4.2	Mounting the Ring Gear	12
4.3	Assembling the Seal Housing	13
4.4	Calculation & Selection of Pre-Load Shims	14
4.5	Drilling and Tapping the Bulkhead Port	15
4.6	Modifying the Bearing Cap	16
4.7	Final Backlash Checking	19
4.8	Profiling the Seal Housing Tube	20
4.9	Setting Up the Bulkhead Fitting	22
4.10	Bench Testing the Air Locker	24
4.11	Reinstalling the Differential and Axles	25
<b>5</b>	<b>Installing the Air System</b>	<b>26</b>
5.1	Mounting the Solenoid	26
5.2	Running & Securing the Air Line	28
5.3	Connection to the Bulkhead Fitting	29
<b>6</b>	<b>Mounting &amp; Connecting the Electrical System</b>	<b>30</b>
6.1	Mounting the Actuator Switch(es)	30
6.2	Wiring the Actuator System	31
<b>7</b>	<b>Testing &amp; Final Assembly</b>	<b>35</b>
7.1	Leak Testing	35
7.2	Testing the Air Locker Actuation	35
7.3	Filling the Differential	36
7.4	Post-Installation Check List	37
<b>8</b>	<b>Parts List</b>	<b>39</b>
8.1	Exploded Assembly Diagram	39
8.2	Specifications	39
8.3	Itemized Parts List	40



# 1 Introduction

## **IMPORTANT :**

**BEFORE ATTEMPTING TO DISMANTLE YOUR VEHICLE FOR THIS INSTALLATION, PLEASE READ THIS INSTALLATION GUIDE IN ITS ENTIRETY, AS WELL AS ALL APPLICABLE SECTIONS OF YOUR VEHICLE MANUFACTURER'S SERVICE MANUAL.**

### 1.1 Pre-Installation Preparation

This booklet is to be used in conjunction with your vehicle manufacturer's service manual. ARB endeavors to account for every possible variation in vehicle model when publishing its installation guides, and guides are updated regularly as new model information becomes available, however, the rapid and globally varied release of some vehicles makes it difficult to insure that your vehicle model has been accurately accounted for. In the case of any technical discrepancies between this guide and your service manual, we strongly advise that you adhere to the specifications and techniques as documented in your service manual.

Although your *ARB Air Locker* comes complete with all the step by step instructions you will need to supplement your vehicle manufacturer's service manual and install your new differential, ARB recommends that you have your *Air Locker* installed by a trained professional. Many ARB distributors around the world have been fully instructed in *Air Locker* installations by ARB, and have gained a wealth of experience and skill from years of performing similar installations.

Once you begin this installation your vehicle will be immobile until all steps of the installation are complete. Make sure your *Air Locker* kit is the correct model for your vehicle and that it contains all of the parts listed on back cover of this booklet. Also be sure you have appropriately equipped yourself with all the necessary tools, parts, and materials to complete this installation (see section 1.2 *Tool-Kit Recommendations*), and that you have allowed for an appropriate amount of vehicle down time.

#### **HINT :**

Place a ✓ mark inside each of the  symbols as you complete each step. It is very important NOT to miss any of the steps!

# 1 Introduction

## 1.2 Tool-Kit Recommendations

Below is a list of tools and supplies you may need to complete this installation. Requirements for your vehicle may vary. Please consult your vehicle service manual for additional recommendations.

### 1.2.1 Tools

---

- Standard automotive sizes (metric and/or imperial) of sockets, wrenches, Allan keys, and drills.
- A dial indicator or other suitable measuring tool for checking ring & pinion backlash.
- A standard automotive feeler gauge.
- A razor knife to cut the nylon tubing.
- A torque wrench. (See vehicle service manual for required torque range.)
- A lubricant drain reservoir.
- Suitable measuring tools to measure a differential for pre-load and/or backlash shimming. (See Section 3 *Bench Measurement*)
- An 11.2mm [7/16"] drill and ¼" NPT tap for bulkhead fitting installation.
- An automotive bearing puller (e.g. ARB Bearing Puller #0770001) or a differential carrier bearing puller.
- A bearing press or arbor press.
- A soft hammer (e.g. copper/rawhide/nylon etc.)

### 1.2.2 Supplies

---

- Thread lubricant/sealant compound for pressure fittings. (e.g., LOCTITE #567 Teflon paste)
- Thread locking compound (e.g., LOCTITE #272)
- A gasket sealant or replacement gasket for your third member.
- A sufficient volume of differential oil to completely refill your housing. (see the *ARB Air Locker Operating and Service Manual* for recommended lubricants)
- A soap and water mixture to test for air leaks.

## 2 Removing the Existing Differential

### 2.1 Vehicle Support

- Safely secure the vehicle on a hoist. We recommend supporting the vehicle on a chassis hoist to keep the differential area at a convenient working height and to leave the wheels and axles free to be rotated and removed.
- Once supported off the ground, release the parking brake and leave the vehicle in neutral. Chock the wheels if necessary.

### 2.2 Differential Fluid Drain

- Clean around the differential drain plug to prevent dirt from entering the differential.
- Position a fluid drain reservoir under the differential.
- Remove fluid drain plug to empty all differential oil.

**HINT :** This is a good time to check for metal particles in your oil and in the bottom of the housing which may indicate a worn bearing or differential component.

### 2.3 Removing the Axles & Differential

- Remove the front wheels from the vehicle.
- Disconnect the drive shaft from the flange of the differential.
- Remove the front axle assembly according to your vehicle manufacturer service manual.
- Secure the assembly to a work bench, and remove the cover plate.
- Remove the oil seal at the end of the axle housing (long axle tube) using suitable tool to gain access to the circlip holding the axle assembly.
- Remove the axle assembly from the differential housing.
- Leave the oil seal on the diff case side in place.

**HINT :** Rubber oil seals can get damaged easily. The flange will usually get deformed during the removal process. If a new seal is needed, contact your local Nissan distributor and quote part number 40227-EA000 (Front Final Drive RHS Seal) for a replacement.

## 2 Removing the Existing Differential

### 2.4 Marking the Bearing Caps

- Using a pointed center punch, gently mark the differential housing and the bearing caps in a way that will enable you to correctly position the cap during reassembly. (Fig. 1.)



### 2.5 Checking the Current Backlash Amount

#### **IMPORTANT:**

This step is a precautionary measure recommended by ARB due to the fact that some after market ring and pinion sets have been manufactured to run with different backlash settings than those specified by your vehicle manufacturer. Although ARB must recommend you set backlash according to your service manual guidelines, we also advise that you compare the backlash measurements taken here to the recommended backlash settings in your vehicle service manual. Measurements found to be outside of your service manual recommendations may indicate the need to deviate from those settings in order to achieve quiet running with a good contact mark.

Refer to your vehicle service manual or your local authorized ARB installer for more information.

## 2 Removing the Existing Differential

- Set a depth indicator on one of the ring gear teeth as in Figure 2.



- While supporting the pinion gear by holding the drive flange, rotate the differential in both directions while observing the maximum variation in depth from the indicator (i.e., the highest value minus the lowest value). This value is referred to as the ring and pinion backlash.
- Rotate the differential center 90° and measure again for accuracy.
- Record the average of all measurements.

### 2.6 Removing the Differential Carrier

- Unbolt and remove the bearing caps.
- Using a suitable tool, carefully remove the differential by pulling forward on the differential carrier.

**NOTE :** **NEVER** spread an aluminium housing as it may initiate cracks on excessive spreading force.

## 3 Bench Measurement

### 3.1 Approximate Backlash Shimming

In order to reproduce a similar pre-load and ring and pinion backlash in your *Air Locker* to that of your original differential, measurements need to be taken so that a shim thickness can be calculated.

- Secure the differential to a work bench.
- Remove the bolts that hold the ring gear in place.
- Using a plastic or copper hammer, tap in a circle around the ring gear to separate it from the differential carrier.
- Remove the original bearings from the differential center using a bearing puller (Fig. 3.).

**NOTE :** Keep the bearings and shims separated so that they can be identified as to which end of the differential they came from.



Figure 3.

- Examine the bearing cups and cones from Fig. 4. for damage or wear and, if necessary, discard them and replace with the same size and type of bearings.

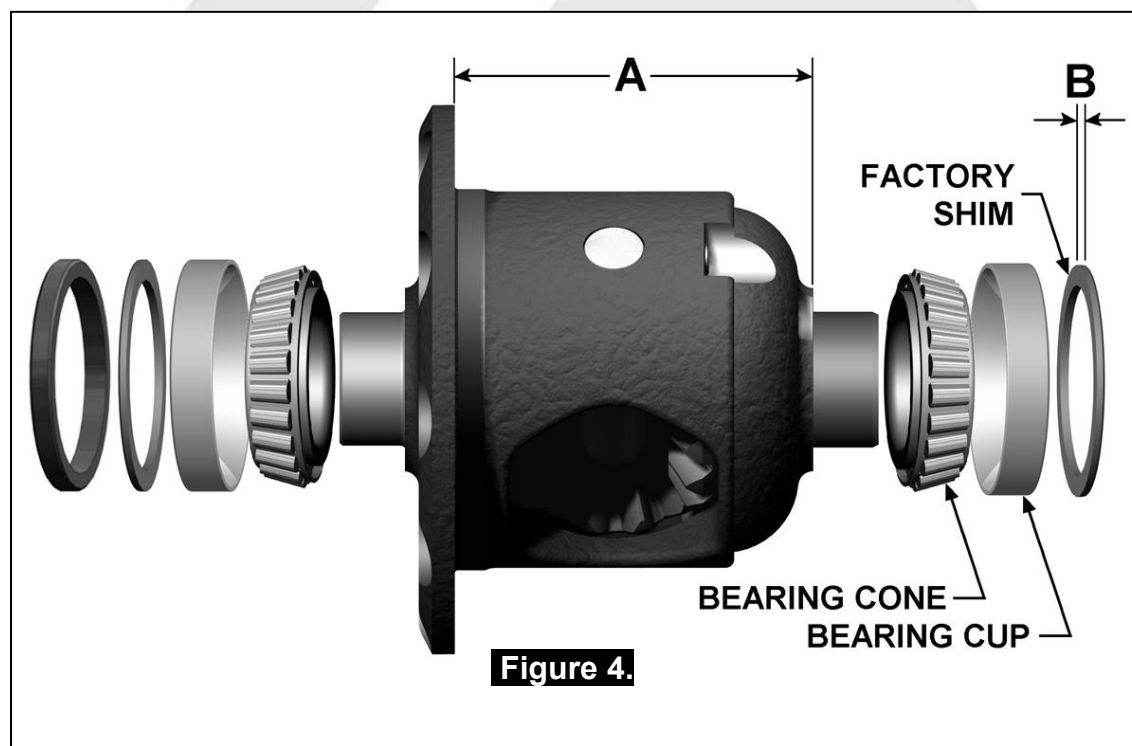
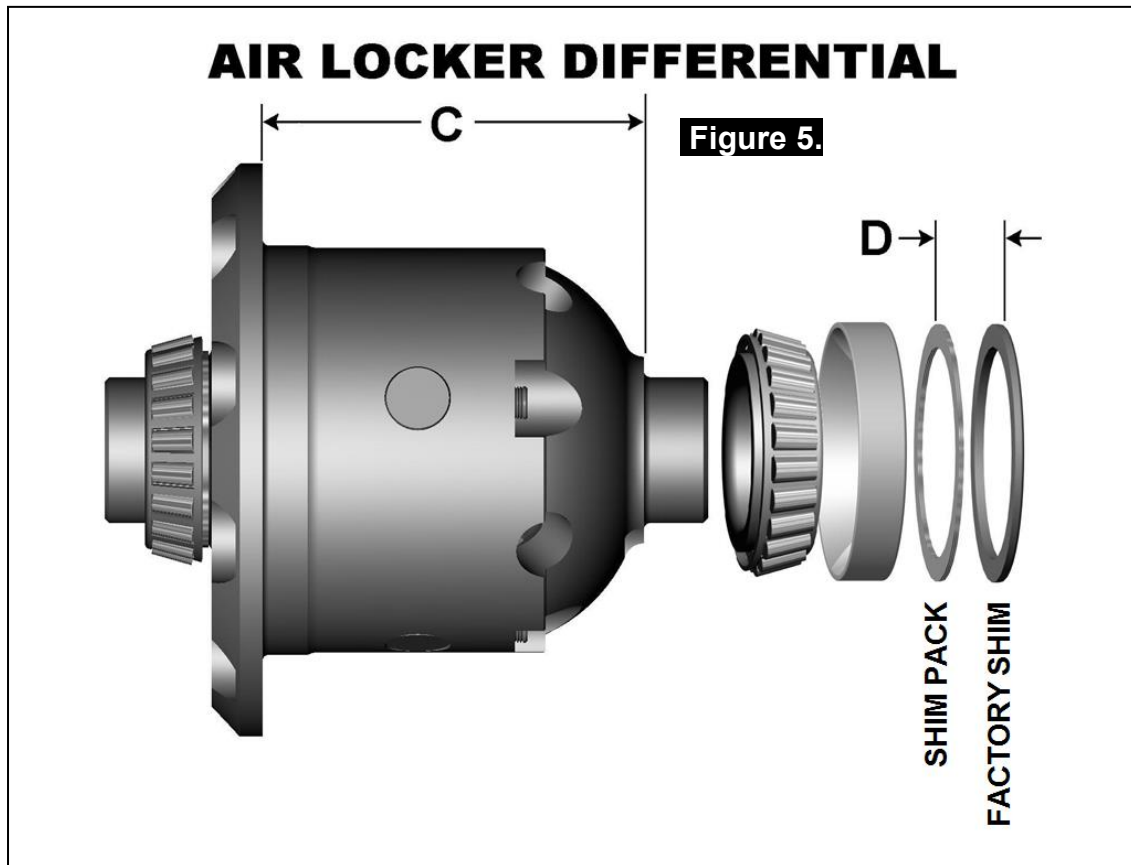

Figure 4.

### 3 Bench Measurement

- Using a caliper or similarly accurate measurement method (i.e., able to take accurate measurements within 0.04mm [0.0015"]), measure the distance from the shoulder of the bearing journal to the ring gear mounting face (shown as 'A' in Fig. 4.) and record this measurement as 'A'.
- Measure the thickness of the factory shim removed from the end of the differential carrier (shown as 'B' in Fig. 4.) and record this measurement as 'B'.



- Measure the distance from the *Air Locker* bearing shoulder to the ring gear mounting face (shown as 'C' in Fig. 5.) and record this measurement as 'C'.

#### 3.2 Calculation & Selection of Shims

Ideally, the measurement you recorded as 'C' from the *Air Locker* differential will closely match 'A' on the existing differential (within 0.1mm [0.004"]) and then the factory shim can be reused on this end, however, quite often these measurements will vary slightly between one factory differential and the next.

### 3 Bench Measurement

If this is the case you must create a new shim pack thickness by using the measurements you recorded earlier to find a desired measurement for 'D' in Fig. 5.

Use the following calculation:

$$A + B - C = D \text{ (Replacement Shim Pack)}$$

**HINT :** If your calculations are correct then the following equation will also be true:

$$A + B - C - D = \text{ZERO}$$

- Create a shim pack to match the thickness calculated as 'D' and add it between the factory shim and the bearing cup.

To achieve the desired shim thickness you can:

- Select shims from the shim kit supplied with your *Air Locker* kit
- Purchase new factory shims at the desired thickness.
- Use a universal shim kit available from most drive train specialists.

**NOTE :** NEVER machine the *Air Locker*.

## 4 Installing the Air Locker

### 4.1 Installing the Carrier Bearings

- With the *Air Locker* well supported in an arbor press, apply a thin film of high pressure grease to both bearing journals.
- Identify the bearings according to where each was removed from the OE diff, and allocate them to the correct sides of the *Air Locker* respectively.
- Press one of the tapered roller bearing cones onto one of the bearing journals of the *Air Locker* until the bearing seats firmly against the bearing journal shoulder (Fig. 6.).

**NOTE :** Never re-use any bearings which are damaged or worn.

- Invert the *Air Locker* and press the second bearing cone onto the opposite bearing journal until the bearing seats firmly against the bearing journal shoulder.

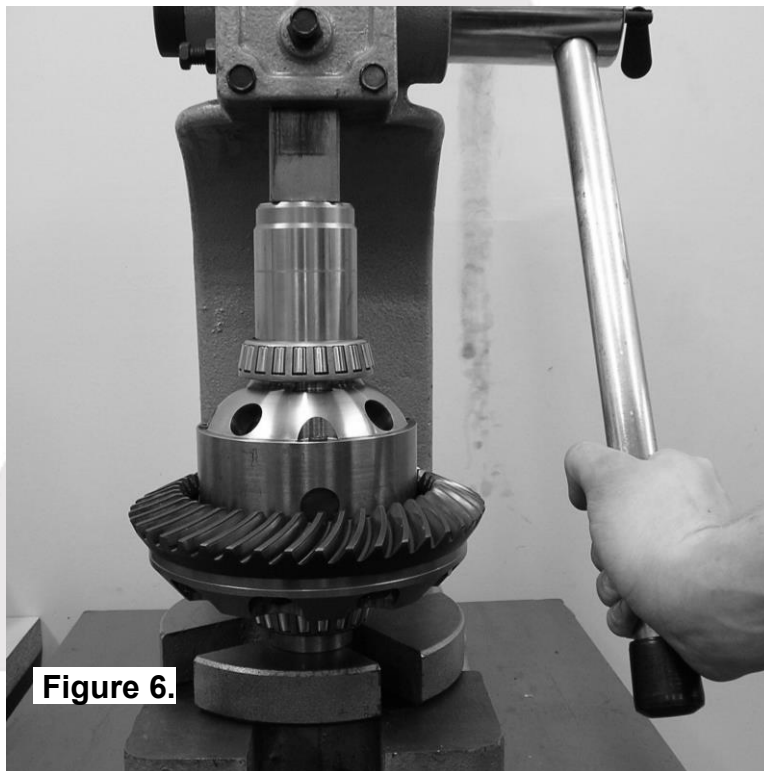

Figure 6.

**NOTE :** Do not add any shims between the seal housing bearing and the bearing seat.

## 4 Installing the Air Locker

### 4.2 Mounting the Ring Gear

- Apply a thin film of high-pressure grease to the ring gear shoulder of the *Air Locker* to prevent seizing.
- Thoroughly clean any thread locking compound or other foreign matter from the holes of the ring gear, the threads of the ring gear bolts, and the mating surfaces of the ring gear and the *Air Locker* flange.

**NOTE :** **Rubbing the ring gear mounting face with a flat oil stone before installation will remove any high spots around the threads.**

- Heat the ring gear to between 80 and 100°C (175 - 212°F) in an oven or in hot water to slightly expand the gear and facilitate assembly.

**NOTE :** **NEVER HEAT GEARS WITH A FLAME! This could damage the hardened surface of the gear and result in premature wear or failure.**

- Dry the ring gear with compressed air (if wet), paying particular attention to the threaded holes.
- Install the ring gear onto the *Air Locker* by aligning the holes in the flange with the tapped holes in the ring gear, then gently tapping it around in a circle with a plastic or copper hammer.

**NOTE :** **Avoid using the bolts to pull down the ring gear as this puts excess strain on the bolts and the differential flange.**

- Apply a thread locking compound to the thread of each ring gear bolt before inserting it.

**NOTE :** **Do not apply threading compound directly into the threaded hole as this could prevent the bolt from reaching its full depth.**

- Tighten the ring gear bolts in a star pattern with a torque wrench according to your vehicle manufacturer's specified torque.

## 4 Installing the Air Locker

### 4.3 Assembling the Seal Housing

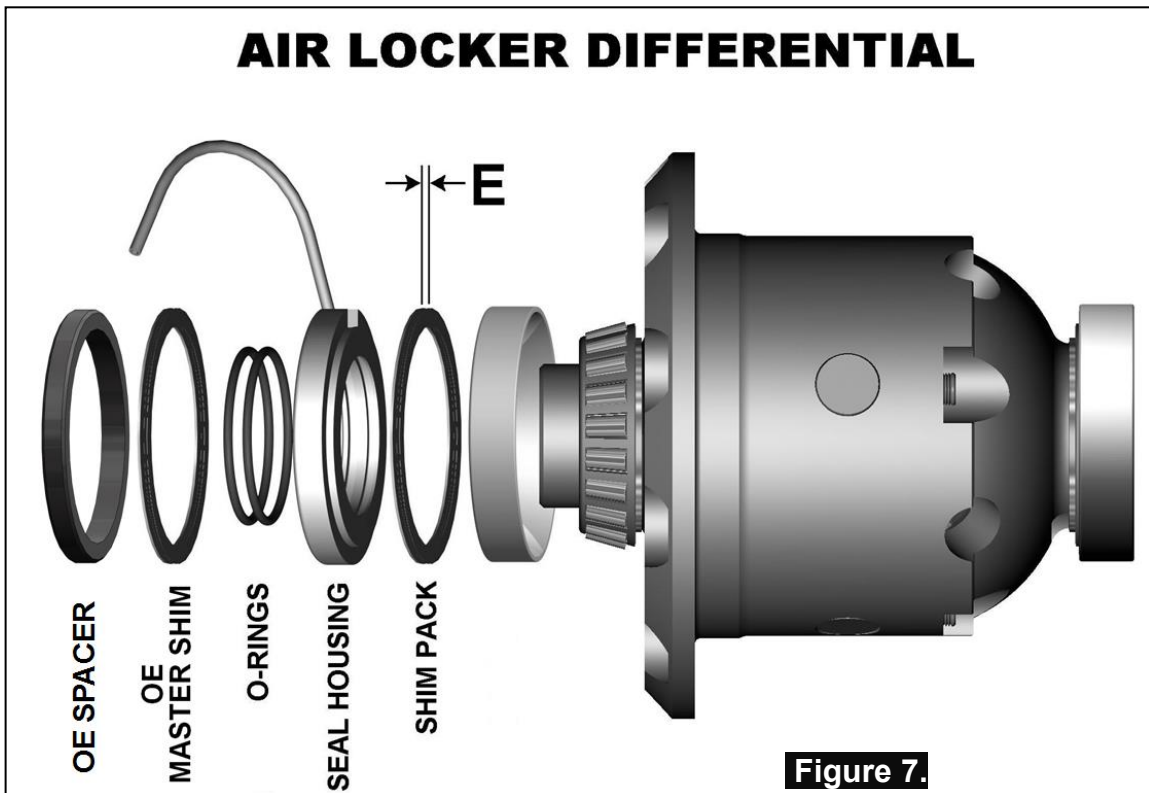

- Make sure the grooves and airway of the seal housing are clean and free from any contaminants (e.g. water, dirt, metal filings, etc.).
- Inspect the seal housing O-rings (supplied) for dirt, damage or other conditions which might cause leaks.
- Generously lubricate the O-rings with oil prior to assembly, then insert them into the grooves of the seal housing.

**NOTE :** When assembling the O-rings, be careful not to leave them twisted when seated in the grooves as this could cause excessive wear and leakage.

- Lubricate the seal housing running surface on the *Air Locker* carrier with oil. Assemble the bearing cup onto the ring gear side.

**NOTE :** No shims should be assembled onto the seal housing at this time. The bearing cup should sit directly against the seal housing.

- Carefully install the seal housing by sliding it all of the way onto the bearing journal with a gentle twisting motion. This will allow the O-rings to engage gently.

### 4.4 Calculation & Selection of Pre-Load Shims

## 4 Installing the Air Locker

In order to pre-load the tapered roller bearings in your *Air Locker*, measurements need to be taken so that a value can be calculated for the shim thickness 'E' in Figure 7.

- Hold the bearing cup and shim pack 'D' (Fig. 5.) in place, and insert the *Air Locker* into the housing.
- Install one bearing cap on the case side. The bearing cap on the seal housing side will need to be drilled as clearance for the seal housing tube.
- Install the bearing cap bolts on the case side finger tight.
- Push the *Air Locker* hard across against the bearing and shim pack 'D', and measure the gap between the seal housing and the OE master shim with a feeler gauge.

**NOTE :** This 'end float' measurement determines the shim thickness necessary to achieve 'neutral pre-load'. Adding more shim than this measurement becomes the actual 'pre-load'.

- Consult your vehicle manufacturer's service manual to determine the carrier bearing pre-load amount specified for your vehicle.
- Add the specified pre-load amount to the measurement taken with the feeler gauge to determine a shim amount for 'E' in Figure 7.

**PRE-LOAD + END FLOAT = SHIM PACK**

- Select suitable shims from the shim kit supplied with your *Air Locker* to make up a shim pack of this thickness. (Refer to section 3.2 for methods of shim adjustment).
- The seal housing will have to be removed in order to add shim pack 'E'. Ensure that the seal housing is re-installed correctly.

## 4 Installing the Air Locker

### 4.5 Drilling and Tapping the Bulkhead Port

An air line port must be drilled and tapped through the differential housing to mount the bulkhead fitting into.

- Mark a spot on the exterior of the differential cover plate in the position shown in Figure 8. (i.e., toward the 10 o'clock hole, in the flat area that will be accessible from the outside and clear of all moving components inside).

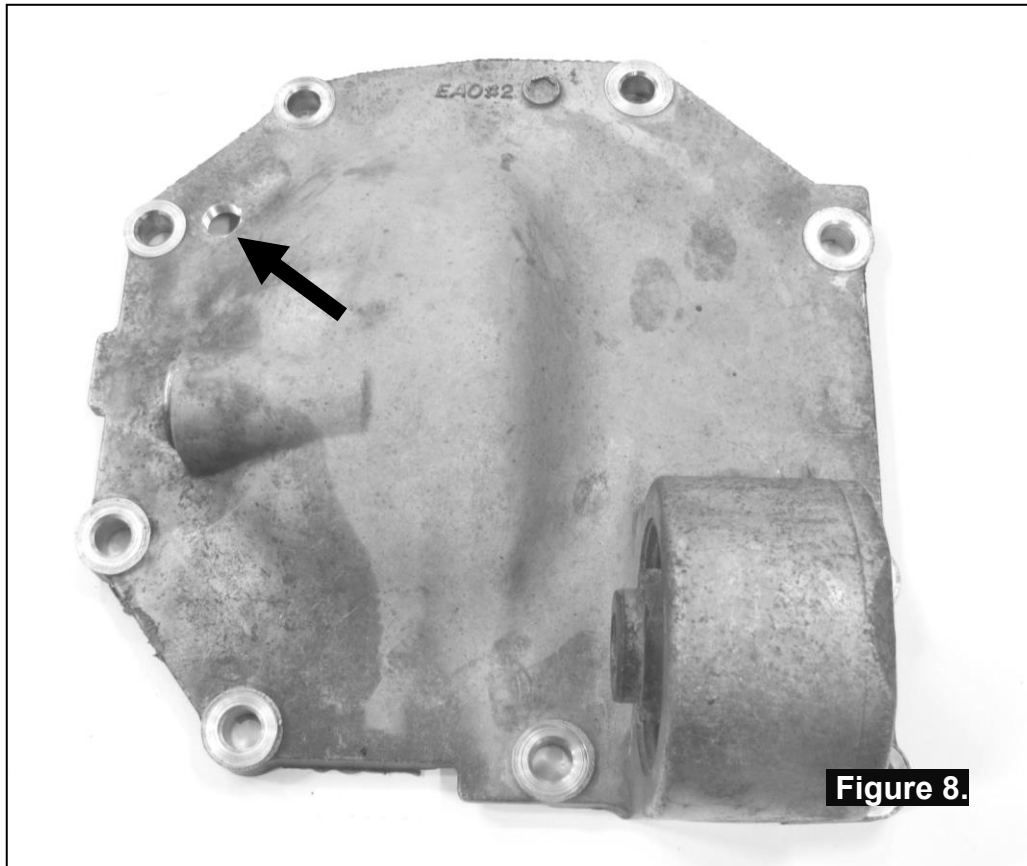

- Secure the differential cover plate to a work bench.
- Drill an 11.2mm [7/16"] diameter hole through the cover plate square to the outside surface.
- Tap the hole from the outside using 1/4"NPT thread tap.
- Remove any sharp edges that may chip off from around the hole and fall into the housing.
- Thoroughly clean the cover plate to remove any filings from drilling.

## 4 Installing the Air Locker

### 4.6 Modifying the Bearing Cap

Clearance for the seal housing tube must be made in the bearing cap.

#### 4.6.1 Marking the Tube Position

- Without using a spreader, fill the gap (end float) between the master shim and the housing with a required thickness of shims.
- Ensure the *Air Locker* is securely fitted in place and there is no significant movement when you push it left and right.
- An accurate measurement for the seal housing tube clearance can now be made.

**NOTE :** Take time and double check when taking your measurements, as bearing caps are custom fitted to the axle housing and cannot be replaced.

- With the seal housing tube pointing straight out, measure the distance from a fixed position inside the differential housing to the center of the seal housing tube. (Fig. 9.)

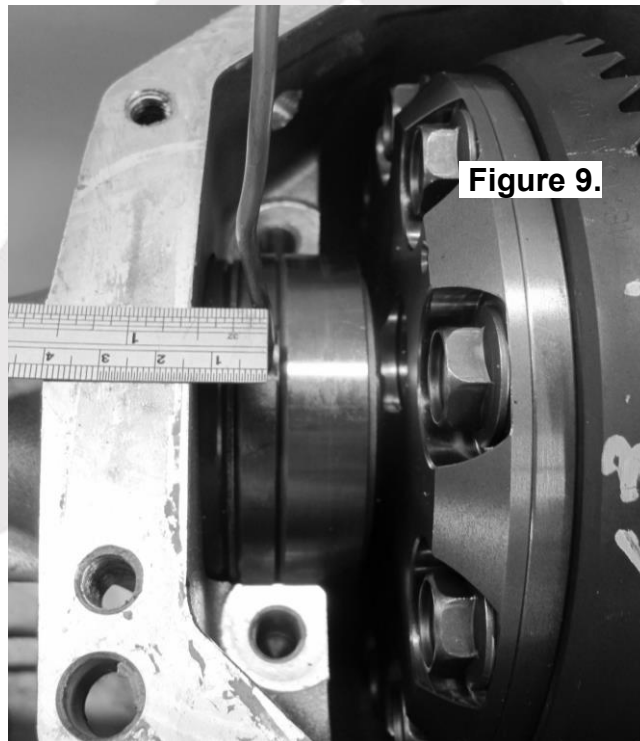
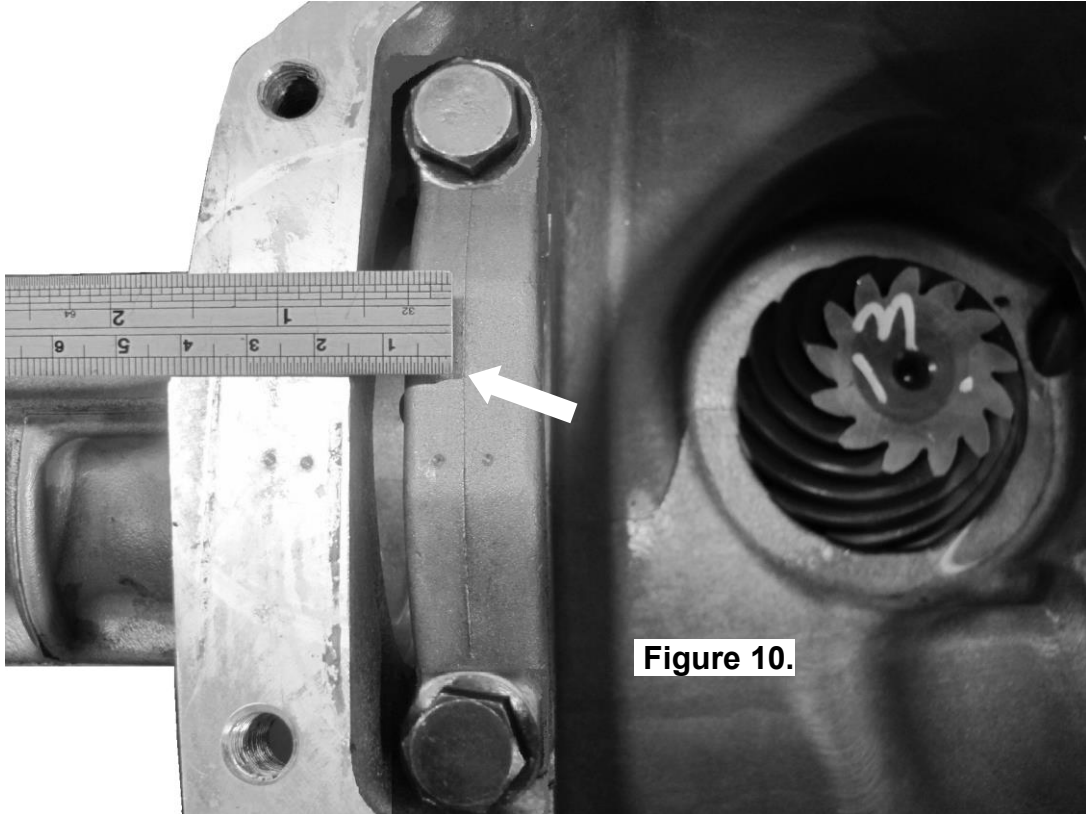

Figure 9.

- Record your findings and recheck for accuracy.
- Remove the bearing cap from the case side of the differential.
- Remove the *Air Locker* from the differential housing.
- Install the seal housing side bearing cap and hand-tighten the bearing cap bolts.

## 4 Installing the Air Locker

- Measure to the bearing cap from exactly the same position on the differential housing that you took the previous measurements from. (Fig. 10.)
- Mark the tube position where the clearance is to be made for the seal housing tube with a center punch.



- Remove the bearing cap from the differential housing.
- Measure the distance from the center punch mark made on the bearing cap to the closest edge of the bearing cap.
- The center punch mark should be greater than 5mm [3/16"] from the closest edge of the bearing cap.

**NOTE :** Do not file a notch or have the hole less than 5mm from the edge as this will weaken the aluminium bearing cap.

## 4 Installing the Air Locker

### 4.6.2 Drilling the Bearing Cap

- Hold the bearing cap steady for drilling in a soft jawed vise clamp.

**NOTE :** Do not apply too much clamping pressure with the vise. The bearing cap may be damaged.

- Using a pedestal drill, drill a 6.35 [1/4"] hole through the bearing cap where the seal housing tube hole has been marked. (Fig. 11.)

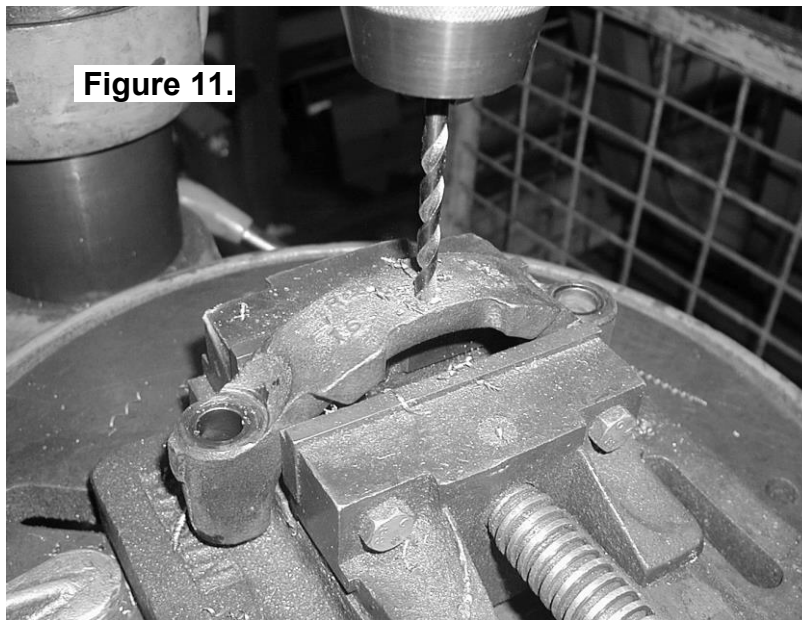

Figure 11.

- The drilled hole must be chamfered remove any sharp edges that may chip-off and fall into the housing. (Fig. 12.)

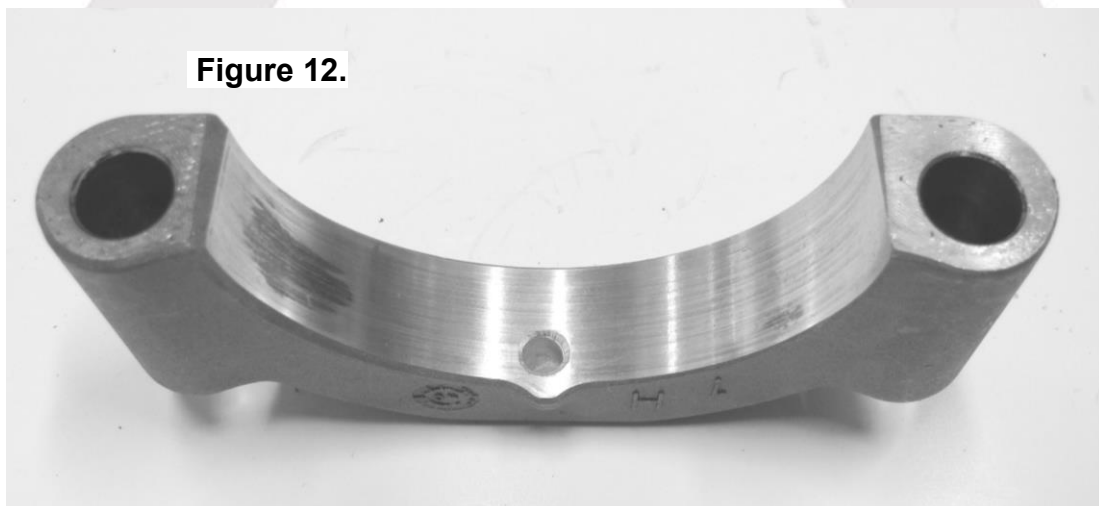

Figure 12.

## 4 Installing the Air Locker

### 4.7 Final Backlash Checking

- Hold shim packs 'D' (Refer to section 3.2) and 'E' (Refer to section 4.4) in position on the *Air Locker*.
- Reinstall the *Air Locker* into the differential housing, ensuring that the seal housing is positioned so that the tube will clear the bearing cap.
- Place the bearing caps in place to align the seal housing.
- Tighten all bearing cap bolts with a torque wrench to the torque specified in your vehicle manufacturer's service manual.
- Set a depth indicator on one of the ring gear teeth as in Fig. 13.
- While supporting the pinion gear by holding the drive flange, rotate the differential in both directions while observing the maximum variation in depth from the indicator (i.e., the highest value minus the lowest value). This value is referred to as the ring and pinion backlash.
- Rotate the differential center 90° and measure again for accuracy.

**Figure 13.**

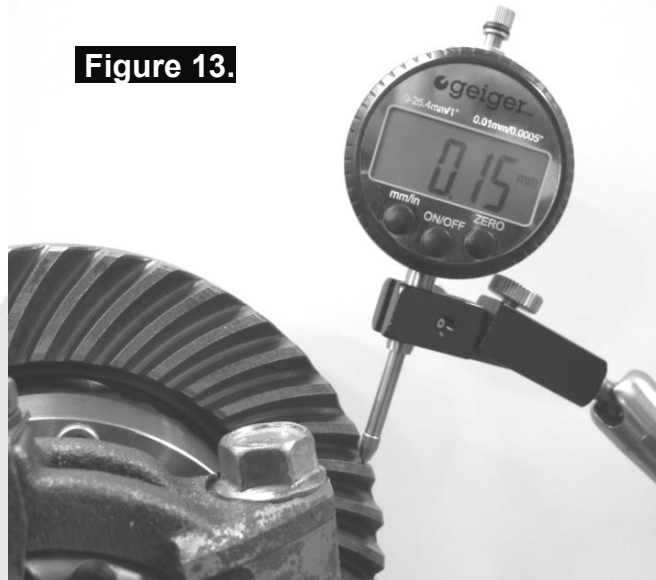

- Refer to your vehicle service manual for the specified maximum and minimum amounts of backlash. If the backlash is not within the specifications then the differential will have to be removed and re-shimmed.

## 4 Installing the Air Locker

### 4.7.1 Re-Shimming the Backlash

**NOTE :** This step is only necessary when adjusting for incorrect backlash.

- Remove the bearing caps.
- Remove the differential.
- To increase the amount of backlash, reduce the shim thickness 'E' (Fig. 7.) and increase the shim thickness 'D' (Fig. 5.) by the same amount. Reverse this step to decrease the backlash.
- Remount the differential as before.
- Check backlash again as before.

### 4.8 Profiling the Seal Housing Tube

- Without using sharp, jagged tools such as pliers (your hands are the best tool for this job), bend the seal housing tube downwards and then upwards as shown (Fig. 14. & 15.), so that it points out of the diff in line with the position of the bulkhead port in the cover plate. Assure that the tube adequately clears all moving parts of the differential assembly. Less than 10mm [3/8"] should be considered too little clearance.



Figure 14.

## 4 Installing the Air Locker

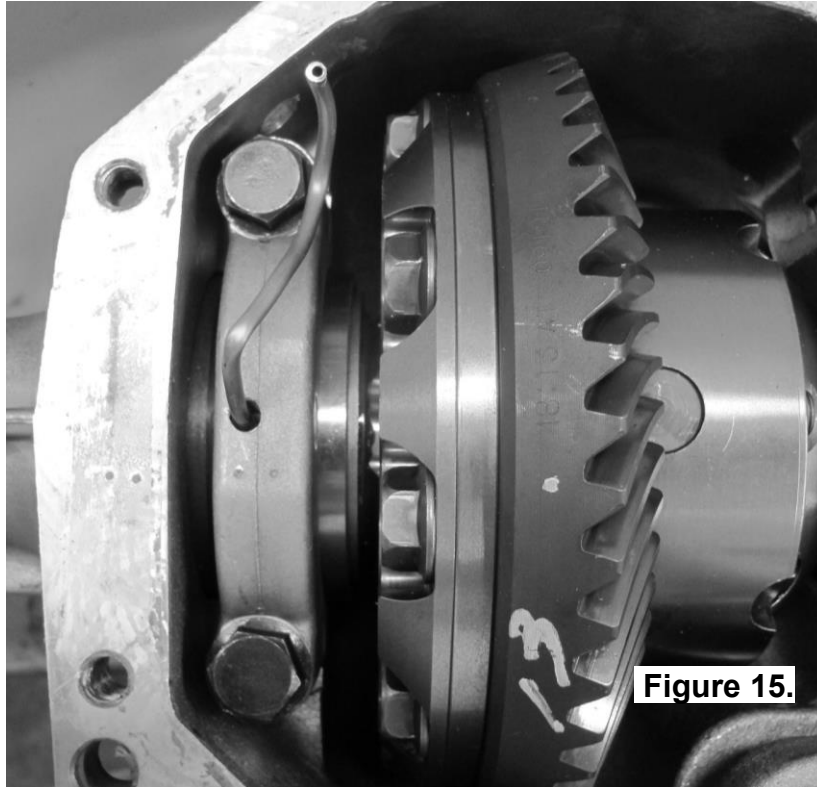

Figure 15.

- Install the differential cover plate onto the differential housing using 2 bolts (hand tight only) to hold the cover in place.
- Rotate the differential center a few turns to make sure the tube is not contacting the center at any point.
- Mark a position on the protruding length of tube approximately 8mm [5/16"] from the bulkhead port (Fig. 16.).
- Remove the cover plate.
- Using an automotive brake line tubing cutter, trim the tube at the position marked.

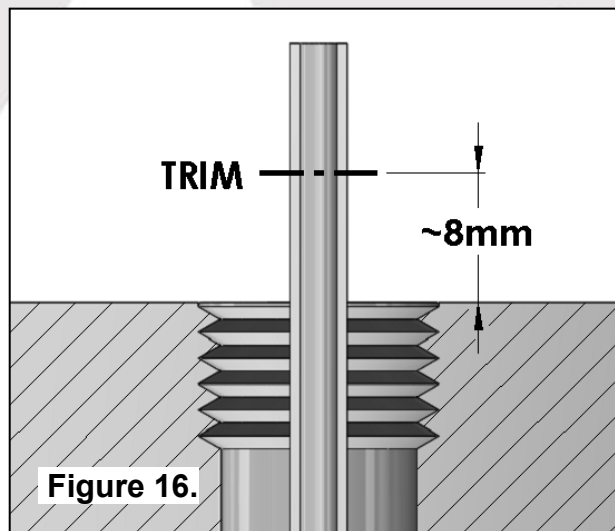

Figure 16.

**NOTE :** Never use a hacksaw for trimming the copper tube as this will leave metal filings in the air system.

## 4 Installing the Air Locker

- Reinstall the differential cover onto the differential housing by firstly inserting the free end of the seal housing tube through the bulkhead port from the inside. No gasket sealant or gasket is required at this time.
- Install 2 bolts hand tight to hold the cover in place.

### 4.9 Setting Up the Bulkhead Fitting

- Apply thread sealant to the outside threads of the bulkhead body.
- Screw the bulkhead body into the tapped hole, and lightly tighten using a 14mm [9/16"] spanner.
- Wipe the area clean of any excess thread sealant (inside and outside of the housing).
- Insert the free end of the seal housing tube into the bulkhead fitting until it protrudes approximately 8mm [5/16"] through the other side.
- From the outside of the housing, assemble one of the small O-rings over the top of the short length of seal housing tube protruding through the bulkhead fitting.
- Install the brass spacer.
- Install the second small O-ring after the spacer.
- While holding the seal housing tube into the bulkhead fitting, insert the chamfered end of the center compression nut over the extended tube as shown in the assembly diagram (Fig. 17.), and screw it into the bulkhead body, and tighten using Pozidriv #3 screwdriver.

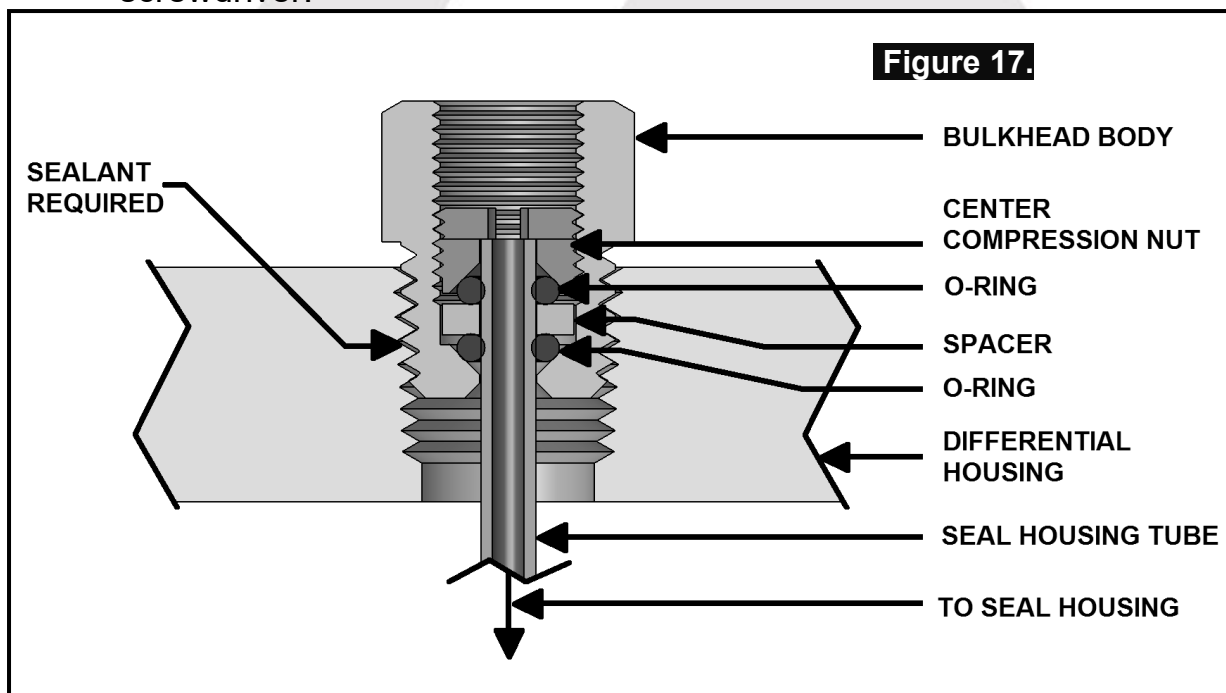

## 4 Installing the Air Locker

**NOTE :** Make sure the seal housing tube is all of the way into the center compression nut while you are tightening it.

**NOTE :** Firmly tighten the center compression nut so that a good seal is formed around the tube.



## 4 Installing the Air Locker

### 4.10 Bench Testing the Air Locker

- To test the *Air Locker*, when 620kPa [90 PSI] shop air is applied to the seal housing tube, the *Air Locker* should engage.
- Check all fittings and the seal housing for air leaks.
- Rotate the differential carrier by turning the pinion flange whilst applying air pressure.

**NOTE :** An accurate way to test for air leaks is to fit a shut-off valve to an air pressure gauge (ARB part # 0770005). Once 620 KPA [90 PSI] is reached close the valve, disconnect the air hose, and watch to see if there is any drop in pressure. If so, this will indicate an air leak. (Fig. 18.)

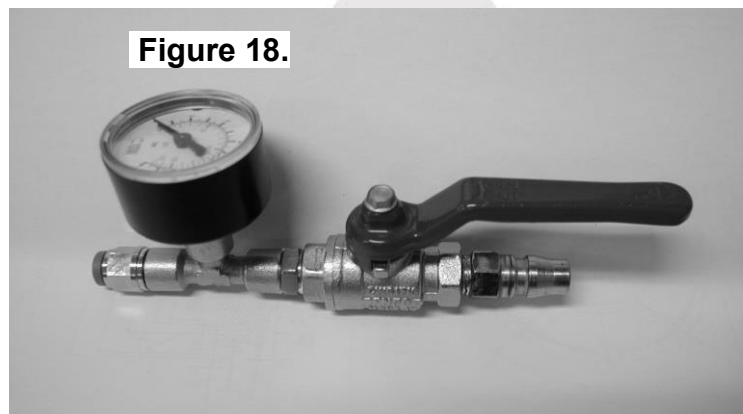

- If a leak is found to be present, spray a soap and water mixture onto the bulkhead air fitting. Bubbles should appear at any leak points.

**NOTE :** Do not spray this soapy mixture inside the differential.

- Check that leaky fittings have been adequately tightened.
- Disassemble, clean threads, and reapply thread sealant if leaking persists.
- If a leak is found at the seal housing, carefully remove the seal housing assembly and examine the O-rings. Be very careful with the O-rings and check for defects, damage, wear, or presence of foreign material in the O-ring grooves. Replace if necessary.

## 4 Installing the Air Locker

### 4.11 Reinstalling the Differential and Axles

- Remove the center compression nut.
- Remove the differential cover plate and apply gasket sealant (or a gasket) on the edges all round, then reinstall it onto the housing.

**NOTE :** Carefully tip the cover plate upside down and shake the two o-rings and spacer out from within the bulkhead body.

- Tighten all cover bolts according to the torque specifications in your vehicle manufacturer's service manual.
- Reinstall the o-rings, spacer, and center compression nut as per Section 4.9.
- Reinstall the axle assembly and make sure the circlip sits fully into the housing groove to securely hold the assembly in place.
- Replace the axle oil seal on the ring gear side.
- Examine the condition of the axle oil seal on the case side. Replace if necessary.
- Reassemble and reinstall the differential assembly according to your vehicle service manual.

**NOTE :** Be careful not to damage the axle oil seals when inserting the axles.

- Reinstall the driveshaft.

## 5 Installing the Air System

### 5.1 Mounting the Solenoid

#### 5.1.1 Connection to an ARB Air Compressor (Fig.19.)

- Remove one of the 1/8" BSP plugs from its port in the compressor tank.
- Apply Teflon paste to the 1/8" BSP nipple on the solenoid and insert it into the port and tighten. The solenoid should be rotated into a position which does not obstruct any other ports on the compressor tank.

**NOTE :** The coil and stem of the solenoid can be removed to make installation easier.

**NOTE :** The solenoid is marked with two #1 ports. If space is tight, a second solenoid can be "daisy-chained" off the first one by removing the plug from the redundant #1 port and screwing the nipple from the second solenoid into it (Fig. 19.).

**NOTE :** The solenoid exhausts compressed air through the center of the black retaining cap when the *Air Locker* is disengaged. Make sure this orifice cannot be obstructed.

- Assemble the 6mm push-in fitting into the solenoid outlet port (stamped "2") and hand tighten.

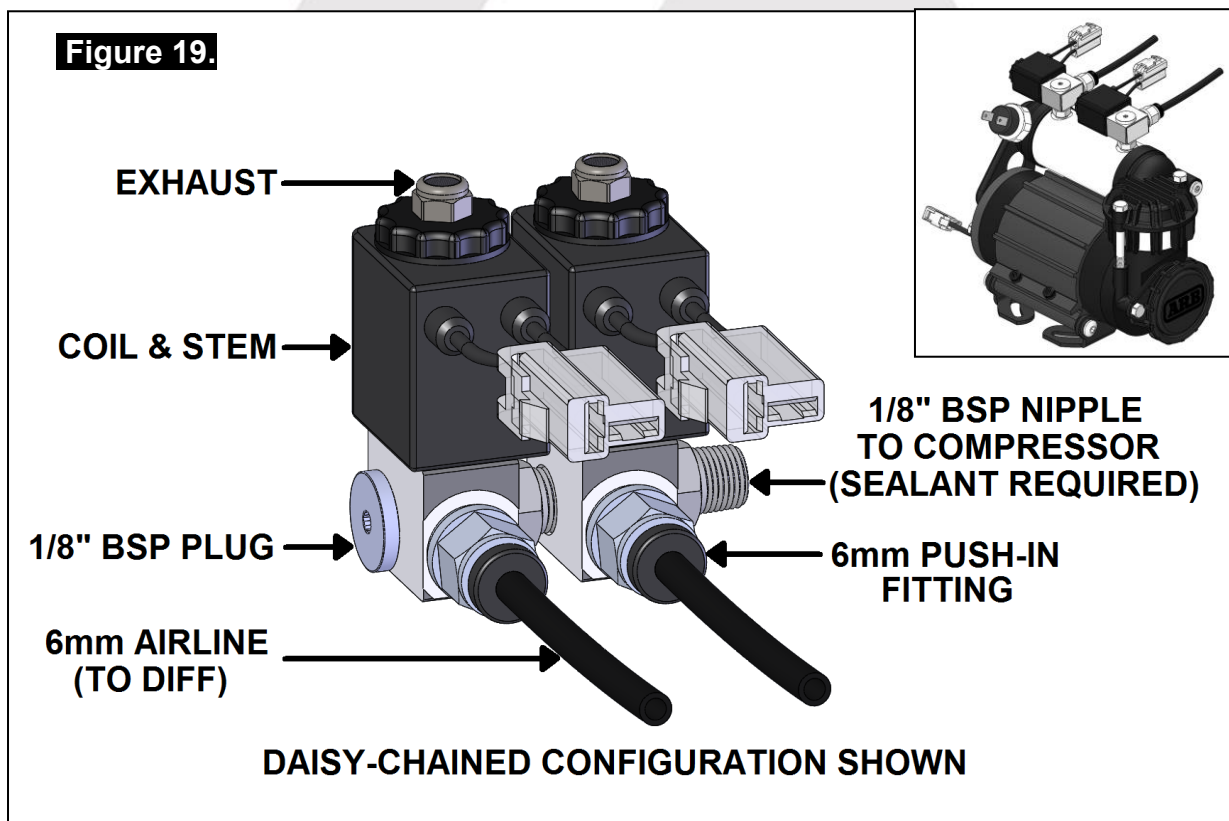

## 5 Installing the Air System

### 5.1.2 Connection to an Alternate Air Source

---

For ease of installation, quality of air supply, and a high level of dependability from your *Air Locker(s)*, ARB strongly recommends use of a genuine ARB Air Compressor, however, the *Air Locker* air system can be operated on any alternate air source that meets each of the following guidelines:

- Must supply a minimum of 85PSI [586kPa].
- The Air source should have a tank capacity that enables it to actuate the *Air Locker(s)* in one charge so that no hesitation is experienced when locking one or two differentials.

**HINT :**     **A good way to insure that you have the necessary capacity is to make sure you can engage, disengage, and then reengage your *Air Locker(s)* without the air source having to regenerate (e.g., without the compressor turning on to refill the tank).**

- Must supply clean air, free of rust, dirt, water, or other foreign matter.
- Must match the 1/8" BSP porting of the *Air Locker* solenoid.
- Mount solenoid within close proximity of the air supply and secure it from the effects of vibration and shock.
- Connect the air supply to the 1/8" BSP inlet port of the solenoid (stamped "1" on the solenoid body) using thread sealant.

#### **IMPORTANT :**

**ARB cannot warrant your *Air Locker(s)* against damage caused as a result of using an alternate air supply. If you have any doubts as to the suitability of your air system to use in an *Air Locker* system, consult your ARB distributor.**

## 5 Installing the Air System

### 5.2 Running and Securing the Air Line

The path taken by the air line from your air source (i.e., compressor) to your *Air Locker* is unique to your vehicle and the position of your air source. Plan ahead carefully when running the air line and always follow these guidelines:

- Account for axle travel when running the line from the axle to a fixed point on the vehicle. Leave enough slack in the air line to allow for maximum suspension travel in both directions.
- Avoid leaving large lengths of air line hanging underneath the vehicle where they may get tangled on rocks, sticks, etc.

**HINT :** **Cable tying the air line to one of your flexible brake lines will account for axle travel and should help keep your line from getting snagged.**

- Run the air line all the way from the compressor to the differential before trimming either end of the line to length. This will save complications that may arise if the air line has to be removed.
- Make sure the line does not contact sharp edges or abrasive surfaces that may damage the air line over time.
- Do not run the air line around tight bends which may kink the air line and restrict or block the air flow.
- Keep the air line well away from your vehicle's exhaust components. Air lines will melt if subjected to extreme heat.
- Do not run more air line than necessary. Excess line volume created when coiling the left over hose, using unusually large diameter hose, etc., will increase drain on the compressor tank resulting in the compressor running more often than needed.
- Support the air line by tying it back with cable ties wherever possible.
- At the solenoid end of the air line, trim the line to length with a sharp knife.

**NOTE :** **To remove the air line from the push-in fitting; push the air line into the fitting as far as possible, then press the flange inward, then pull the air line free of the fitting.**

- To attach the air line to the push-in fitting of the solenoid; insert the line firmly into the fitting, pull outward on the flange of the fitting while holding the line as far into the fitting as possible, and then gently pull outward on the air line to clamp the line in place.

## 5 Installing the Air System

### 5.3 Connection to the Bulkhead Fitting

- Trim the air line to length using a sharp knife.
- Assemble an aluminium washer onto the banjo bolt and insert through the banjo fitting. Assemble second aluminium washer and tighten into bulkhead fitting using a 14mm [9/16"] spanner. (Fig.20.)
- Apply thread sealant to the tapered thread of the compression fitting body and screw into the banjo fitting. Tighten using a 12mm spanner.
- Insert the outer compression nut and ferrule over the air line. Ferrule should be orientated as per Fig.20.

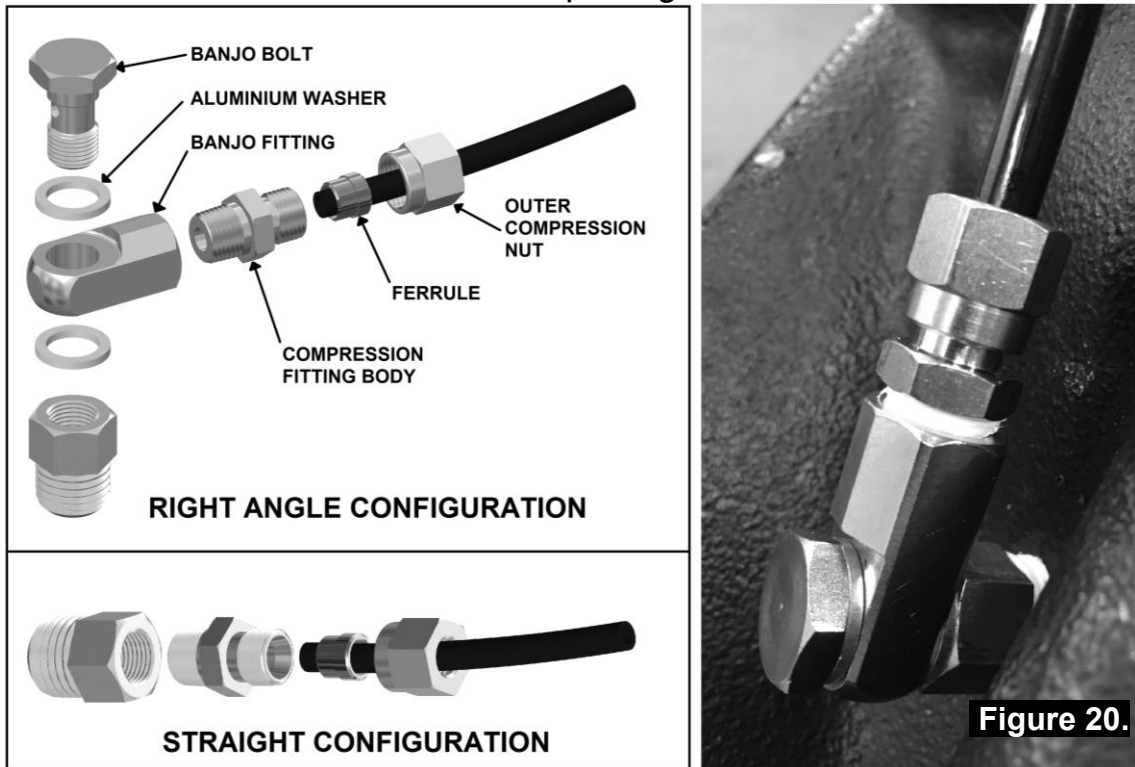

- Push the airline into the compression fitting body and screw the outer nut down onto it. Using a 12mm spanner, tighten the outer nut onto the compression fitting body.

**NOTE :** Some force is required to crush the ferrule, however the outer compression nut will tighten against a stop. Over tightening will not create a better seal.

- Secure any loose sections of tube with a cable tie.

**NOTE :** When right angle routing of the tube is not required, screw the compression fitting body straight into the bulkhead fitting body (Fig.20.).

## 6 Mounting & Connecting the Electrical System

### 6.1 Mounting the Actuator Switch(es)

*Air Locker* actuator switch(es) can be easily panel mounted inside the vehicle in a 21mm x 36.5mm [0.83" x 1.44"] rectangular cutout.

**NOTE :** Only attach the cover plate to the face of the switch once the switch has been mounted and wired correctly as the cover plates are designed to be difficult to remove.

For reasons of safety and for ease of operation, the *Air Locker* actuator switch(es) should be mounted in a location picked to best suit the operator. Make sure you have taken the following points into consideration:

- Switch(es) MUST be mounted and should never be allowed to simply dangle from the wiring loom during vehicle use.
- Switch(es) should be within easy reach of the driver. Ideally, any *Air Locker* switch should be able to be operated without physical effort or distraction to the driver.
- Switch(es) should be mounted within the line of sight of the driver so that switch position ('ON' or 'OFF') can be visually determined by the rocker position and the illumination state.
- The position of the switch(es) should best eliminate any possibility of accidental operation by the driver or one of the passengers.
- Switch cutout position(s) must be located in an area with a minimum of 50mm [2"] of clearance behind the face of the cutout.
- Switch(es) should not be mounted where they will be exposed to water (e.g., in the lower section of an inner door panel).
- ARB recommends that you apply the *Air Locker* Warning Sticker (ARB part # 210101) within close visual proximity of the switch location.

**NOTE :** If no adequate position can be found on existing dashboard panels, a surface mounted bracket (Fig. 21.) may be purchased from your ARB *Air Locker* distributor to suit 1, 2, or 3 switches.

## 6 Mounting & Connecting the Electrical System



### 6.2 Wiring the Actuator System

#### 6.2.1 Connection to an ARB Air Compressor

When wiring the *Air Locker* actuator switch(es) and solenoid(s) to an ARB Air Compressor, all connections can easily be set up directly from the supplied wiring loom. (Fig. 22.)

**NOTE :** 180409 model loom shown for reference only. Refer to your ARB Air Compressor Installation Guide for details on configuring your installation.

# 6 Mounting & Connecting the Electrical System

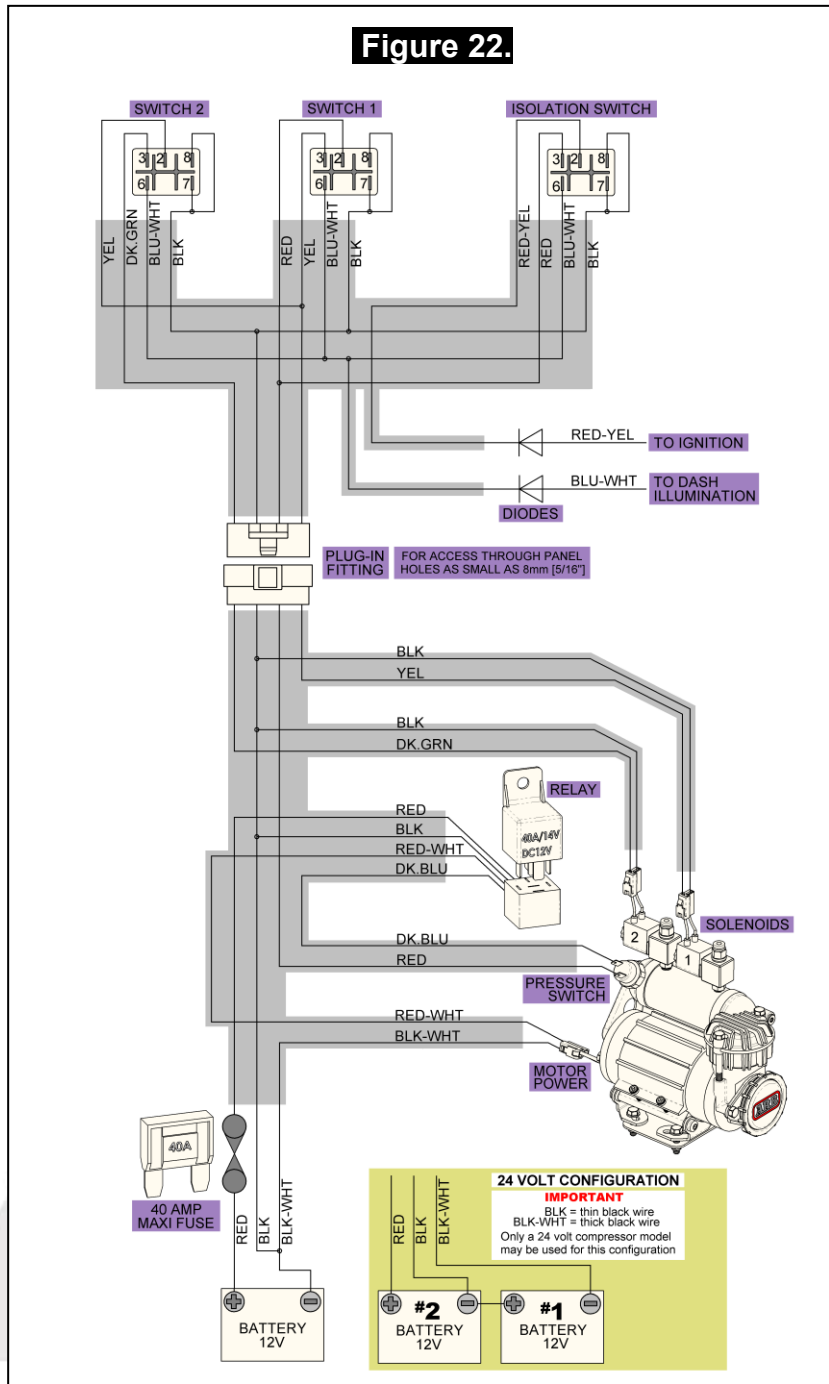

## 6 Mounting & Connecting the Electrical System

### 6.2.2 Connection to an Alternate Air Source

When connecting the actuation switch to an alternate air source, the switch(es) should be wired according to figures 24. and 25., depending on whether one or two *Air Lockers* will be installed in the vehicle.

#### 6.2.2.1 Single Air Locker System

- If only one *Air Locker* is to be installed in the system, the switch and solenoid should be wired according to figure 24. regardless of whether the *Air Locker* has been installed in the front or rear axle of the vehicle.
- Attach the appropriate switch cover (i.e., 'FRONT' or 'REAR') to the switch.

**NOTE :** Refer to Figure 23. for the correct switch terminal identification and switch orientation.

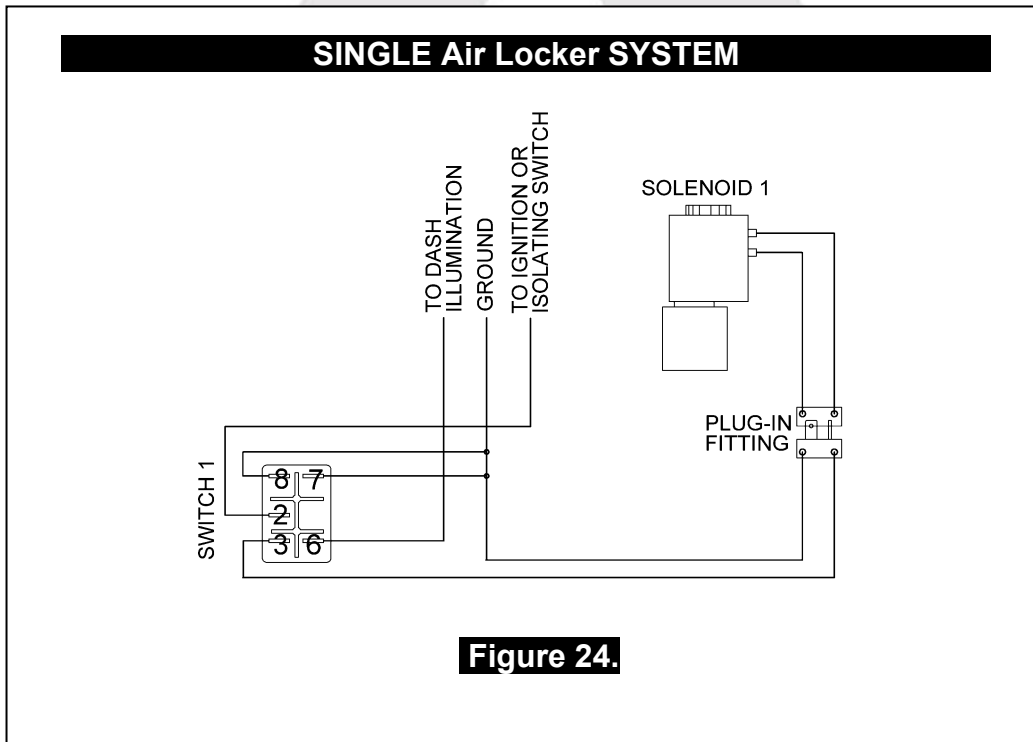

## 6 Mounting & Connecting the Electrical System

### 6.2.2.2 Dual Air Locker System

- If two *Air Lockers* are to be installed in the system, ARB recommends that the switches and solenoids be wired according to figure 25. For safety reasons, this configuration allows SOLENOID 2 to be actuated only if SOLENOID 1 is already on.
- Attach the “REAR AIR LOCKER” switch cover to SWITCH 1, and the “FRONT AIR LOCKER” switch cover to SWITCH 2.

**NOTE :** Refer to Figure 23. for the correct switch terminal identification and switch orientation.

- Configure SOLENOID 1 as the air line leading to the rear axle *Air Locker*, and SOLENOID 2 as the air line leading to the front axle *Air Locker*.

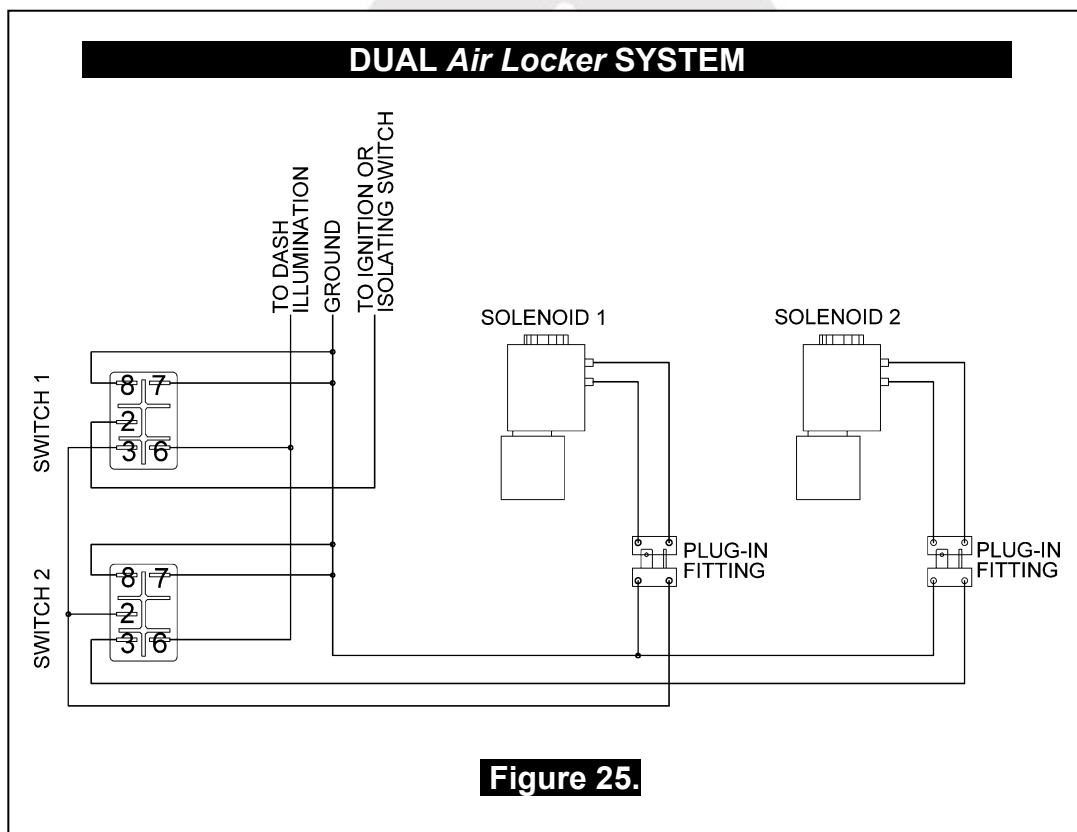

## 7 Testing & Final Assembly

### 7.1 Leak Testing

- With the vehicle parked and the engine off, turn the compressor on and wait until the air system is fully charged.

**NOTE :** With the *Air Locker(s)* disengaged, the air source (i.e., compressor) should not have to recharge over time. Intermittent recharging without *Air Locker* use usually indicates a leak at the solenoid fittings or at the compressor tank O-ring seal.

- Actuate the *Air Locker(s)*.
- The compressor should not come on again for a period of at least 15min. Air system recharging within that time period would indicate that a leak is present in the system.

**NOTE :** If an alternate air source (e.g., an air cylinder or a belt driven air pump) is used instead of a compressor, the air system will have to be leak tested with a pressure gauge and a shut-off valve in series before the solenoid input.

- If a leak is found to be present, spray a soap and water mixture onto all air fittings in the system while the compressor is fully charged. Bubbles should appear at any leak points.
- Check that leaky fittings have been adequately tightened.
- Disassemble, clean threads, and reapply thread sealant if leaking persists.

### 7.2 Testing the Air Locker Actuation

To test that your air system, electrical system, and your *Air Locker* differential is functioning correctly:

- Support the vehicle such that the wheels are free to rotate (e.g., on axle stands, a chassis hoist, etc.)
- Leave the parking brake off, the transmission in neutral, and the *Air Locker* switch 'OFF'.

## 7 Testing & Final Assembly

- Turn the ignition to the 'ON' position (leaving the motor off). The large illuminating symbol on the *Air Locker* switch cover should be 'OFF'.
- Turn the compressor (or alternate air source) on to charge the air supply up to its maximum pressure.
- Rotate one wheel by hand.
- The wheel should rotate freely and the opposite wheel should be turning in the opposite direction without any resistance or mechanical noise from within the differential.
- Turn the *Air Locker* switch to the 'ON' position. The illuminated symbol on the switch cover should light up.
- Rotate the same wheel again.
- Both wheels should rotate together.
- Turn the switch off again.
- Rotate the same wheel.
- The wheels should again rotate in opposite directions.

### 7.3 Re-Sealing & Filling the Differential

**NOTE :** Consult the *ARB Air Locker Operating & Service Manual* for recommendations on differential lubricant specifications.

- Replace the differential cover using gasket sealant or a new standard differential cover gasket for your make of vehicle.
- Refill the differential until level with the filler hole.
- Rotate the differential center 2 full turns.
- Check the oil level and add oil if necessary.
- Replace filler plug (apply thread sealant to filler plug before inserting if it is a threaded type plug).
- Wipe differential housing clean of any oil or grease which may collect dirt or other abrasive particles.

## 7 Testing & Final Assembly

### 7.4 Post-Installation Check List

Now that the *Air Locker* installation has been completed, ARB recommends that you take the time to complete the following check list just to insure that you haven't missed any of the vital steps.

- The air system has been leak tested.
- Thread locking compound was used on the ring gear bolts.
- All torque settings comply with the vehicle manufacturer's specs and were set with an accurate torque wrench.
- Differential fluid complies with ARB recommendations and has been filled to the correct level.
- All air lines and wiring have been securely cable tied to resist snagging.
- Switch(es) have been securely mounted within operator reach, yet well away from danger of accidental engagement.
- Switch(es) function properly and illuminate to indicate that *Air Locker(s)* are engaged.
- All operators who are to use the *Air Locker* have read, and fully understand the *ARB Air Locker Operating & Service Manual*.
- The *Air Locker* Warning Sticker has been located within close proximity of the actuator switch(es).

INSTALLATION PERFORMED BY: \_\_\_\_\_

DATE OF INSTALLATION: \_\_\_\_\_

ODOMETER READING: \_\_\_\_\_

ARB AIR LOCKER SERIAL No: \_\_\_\_\_





## 8 Parts List

**RD180**

Nissan R180A,27 SPL,3.69 & UP

### 8.1 Exploded Assembly Diagram (See itemized parts list overleaf)

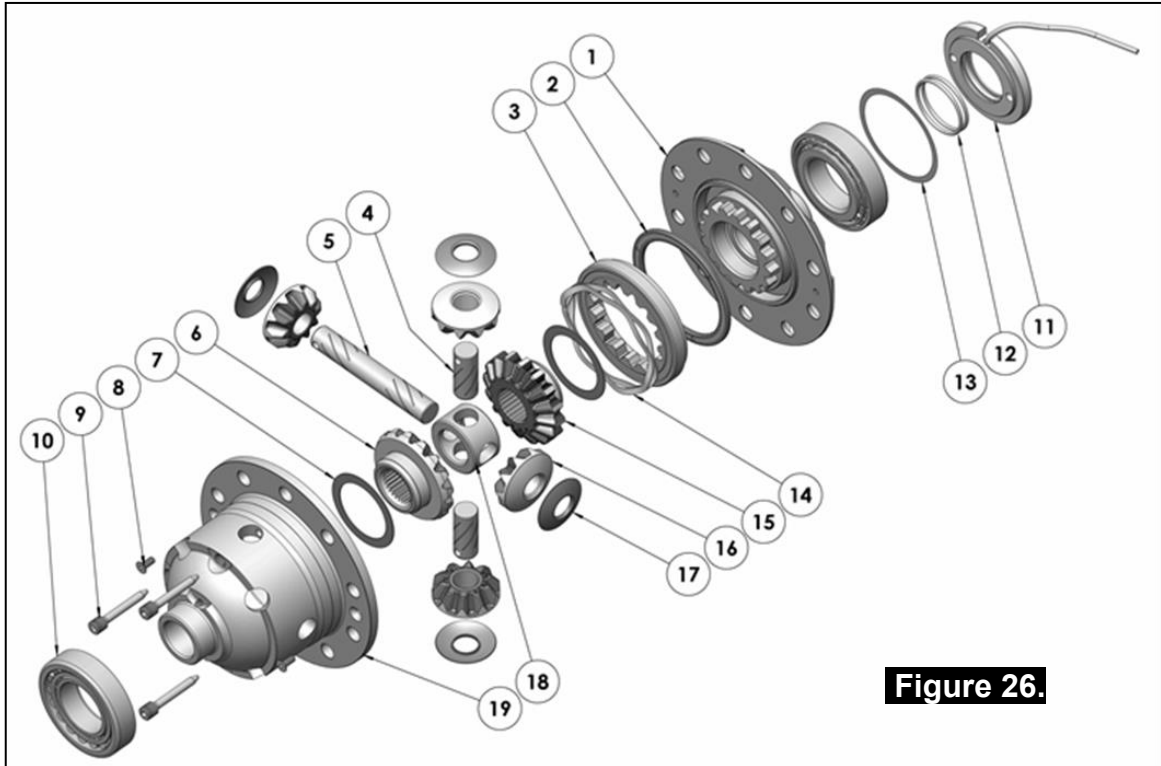

**Figure 26.**

### 8.2 Specifications

Axle Spline	27 tooth, Ø27.8mm [1.09"]
Ratio Supported	3.69 & Up
Ring Gear ID	115.0mm [4.53"]
Ring Gear Bolts	10 bolts on Ø142mm [5.59"]
Ring Gear Bolts Size	12mm
Ring Gear Torque	169Nm [125 ft-lb]
Backlash	0.10-0.15mm [0.004"-0.006"]
Bearing Cap Torque	136Nm [100 ft-lb]

## 8 Parts List

### 8.3 Itemized Parts List

(See exploded diagram Figure 26.)

ITEM #	QTY	DESCRIPTION	PART #	NOTES
1	1	FLANGE CAP KIT	028516SP	
2	1	BONDED SEAL	160701SP	
3	1	CLUTCH GEAR & WAVESPRING KIT	050903SP	
4	2	SHORT CROSS SHAFT	061402SP	
5	1	LONG CROSS SHAFT	061302SP	
6	1	SIDE GEAR	SEE NOTE	2
7	2	SIDE GEAR THRUST WASHER	SEE NOTE	3
8	1	COUNTERSUNK SCREW (PK OF 2)	200213SP	
9	1	RETAINING PIN SET (PK OF 4)	120601SP	
10	*	TAPERED ROLLER BEARING	NOT SUPPLIED	
11	1	SEAL HOUSING KIT	081819SP	
12	1	SEAL HOUSING O-RINGS (PK OF 2)	160206-2	1
13	1	SHIM KIT	SHK008	
14	1	WAVESPRING	150702SP	
15	1	SPLINED SIDE GEAR	SEE NOTE	2
16	4	PINION GEAR	SEE NOTE	2
17	4	PINION THRUST WASHER	SEE NOTE	3
18	1	SPIDER BLOCK	070503SP	
19	1	DIFFERENTIAL CASE	013116SP	
*	1	BULKHEAD FITTING (BANJO TYPE)	170114	4
*	1	AIR LINE (6mm DIA X 6m LONG)	170314SP	4
*	1	SOLENOID VALVE (12V)	180103	
*	1	SWITCH FR LOCKER	180223SP	
*	1	CABLE TIE (PK OF 25)	180305	
*	1	OPERATING & SERVICE MANUAL	210200	
*	1	INSTALLATION GUIDE	2102180	

\* *Not illustrated in exploded view*

### NOTES

- 1 For replacement O-rings use only BS130 Viton 75.
- 2 Available only as complete 6 gear set # 728J091
- 3 Available only as complete thrust washer kit #730J01
- 4 All diffs produced before serial #17070001 came with 5mm air connection system.  
For information contact ARB.
- For ratios of 3.54:1 and down, refer to RD181 ([Section 2.181](#))

Part No. 2102180  
Revision 11/07/2025  
Copyright © 2015 by ARB Corporation Limited

