



# RD198

VW AMAROK REAR

---

AIR OPERATED  
LOCKING DIFFERENTIAL  
INSTALLATION GUIDE

---

No liability is assumed for damages resulting in the use of the information contained herein.  
*ARB AIR LOCKER* Locking Differentials and *AIR LOCKER* are trademarks of ARB Corporation Limited.  
Other product names used herein are for identification purposes only and may be trademarks of their respective owners.

---

# **ARB 4x4 ACCESSORIES**

## **Corporate Head Office**

**42-44 Garden St  
Kilsyth, Victoria  
AUSTRALIA  
3137**

**Tel: +61 (3) 9761 6622  
Fax: +61 (3) 9761 6807**

**Australian enquiries  
North & South American enquiries  
Other international enquiries**

**[sales@arb.com.au](mailto:sales@arb.com.au)  
[sales@arbusa.com](mailto:sales@arbusa.com)  
[exports@arb.com.au](mailto:exports@arb.com.au)**

---

**[www.arb.com.au](http://www.arb.com.au)**

## Table of Contents:

<b>1</b>	<b>Introduction</b>	<b>3</b>
1.1	Pre-Installation Preparation	3
1.2	Tool-Kit Recommendations	4
<b>2</b>	<b>Removing the Existing Differential</b>	<b>5</b>
2.1	Vehicle Support	5
2.2	Differential Fluid Drain	5
2.3	Removing the Axles	5
2.4	Marking the Bearing Caps	7
2.5	Checking the Current Backlash Amount	8
2.6	Removing the Differential Carrier	9
<b>3</b>	<b>Installing the Air Locker</b>	<b>11</b>
3.1	Drilling and Tapping the Bulkhead Port	11
3.2	Assembling the Seal Housing	12
3.3	Approximate Backlash Shimming	13
3.4	Calculation & Selection of Backlash Shims	15
3.5	Installing the Carrier Bearings	16
3.6	Mounting the Ring Gear	16
3.7	Preload Shim Measurement	18
3.8	Setting up the Bulkhead Fitting	20
3.9	Profiling the Seal Housing Tube	22
3.10	Bench Testing the Air Locker	23
3.11	Reinstalling Differential and Axles	24
3.12	OE Diff Lock Replacement	24
<b>4</b>	<b>Installing the Air System</b>	<b>25</b>
4.1	Mounting the Solenoid	25
4.2	Running & Securing the Air Line	27
4.3	Connection to the Bulkhead Fitting	28
<b>5</b>	<b>Mounting &amp; Connecting the Electrical System</b>	<b>30</b>
5.1	Mounting the Actuator Switch(es)	30
5.2	Wiring the Actuator System	31
<b>6</b>	<b>Testing &amp; Final Assembly</b>	<b>34</b>
6.1	Leak Testing	34
6.2	Testing the Air Locker Actuation	34
6.3	Filling the Differential	35
6.4	Post-Installation Check List	36
<b>7</b>	<b>Parts List</b>	<b>37</b>
7.1	Exploded Assembly Diagram	37
7.2	Specifications	37
7.3	Itemized Parts List	38



# 1 Introduction

## **IMPORTANT :**

**BEFORE ATTEMPTING TO DISMANTLE YOUR VEHICLE FOR THIS INSTALLATION, PLEASE READ THIS INSTALLATION GUIDE IN ITS ENTIRETY, AS WELL AS ALL APPLICABLE SECTIONS OF YOUR VEHICLE MANUFACTURER'S SERVICE MANUAL.**

### 1.1 Pre-Installation Preparation

This booklet is to be used in conjunction with your vehicle manufacturer's service manual. ARB endeavors to account for every possible variation in vehicle model when publishing its installation guides, and guides are updated regularly as new model information becomes available, however, the rapid and globally varied release of some vehicles makes it difficult to insure that your vehicle model has been accurately accounted for. In the case of any technical discrepancies between this guide and your service manual, we strongly advise that you adhere to the specifications and techniques as documented in your service manual.

Although your *ARB Air Locker* comes complete with all the step by step instructions you will need to supplement your vehicle manufacturer's service manual and install your new differential, ARB recommends that you have your *Air Locker* installed by a trained professional. Many ARB distributors around the world have been fully instructed in *Air Locker* installations by ARB, and have gained a wealth of experience and skill from years of performing similar installations.

Once you begin this installation your vehicle will be immobile until all steps of the installation are complete. Make sure your *Air Locker* kit is the correct model for your vehicle and that it contains all of the parts listed on back cover of this booklet. Also be sure you have appropriately equipped yourself with all the necessary tools, parts, and materials to complete this installation (see Section 1.2 *Tool-Kit Recommendations*), and that you have allowed for an appropriate amount of vehicle down time.

#### **HINT :**

Place a ✓ mark inside each of the  symbols as you complete each step. It is very important NOT to miss any of the steps!



# 1 Introduction

## 1.2 Tool-Kit Recommendations

Below is a list of tools and supplies you may need to complete this installation. Requirements for your vehicle may vary. Please consult your vehicle service manual for additional recommendations.

### 1.2.1 Tools

- Standard automotive sizes (metric and/or imperial) of sockets, wrenches, Allan keys, and drills.
- A dial indicator or other suitable measuring tool for checking ring & pinion backlash.
- A differential housing spreader, to facilitate removal of the carrier. (e.g., ARB Differential Spreader #0770003)
- A razor knife suitable for cutting nylon tubing.
- A torque wrench. (See your vehicle service manual for the required torque range.)
- A lubricant drain reservoir.
- A 11.2mm [7/16"] drill and ¼"NPT tap for bulkhead fitting installation.
- An automotive bearing puller (e.g., ARB Bearing Puller #0770001) or a differential carrier bearing puller.
- A suitable shim driver (e.g., ARB Shim Driver #0770004)
- A slide hammer.
- A bearing press or arbor press.

### 1.2.2 Supplies

- Thread lubricant/sealant compound for pressure fittings (e.g., LOCTITE #567 Teflon past)
- Thread locking compound (e.g., LOCTITE #272)
- A gasket sealant or replacement gasket for your third member.
- A sufficient volume of differential oil to completely refill your housing. (See the *ARB Air Locker Operating and Service Manual* for recommended lubricants)
- A soap and water mixture to test for air leaks.

## 2 Removing the Existing Differential

### 2.1 Vehicle Support

- Safely secure the vehicle on a hoist. We recommend supporting the vehicle on a chassis hoist to keep the differential area at a convenient working height and to leave the wheels and axles free to be rotated and removed.
- Once supported off the ground, release the parking brake and leave the vehicle in neutral. Chock the wheels if necessary.

### 2.2 Differential Fluid Drain

**HINT :** This is a good time to check for metal particles in your oil, on your drain plug, or in the bottom of the housing which may indicate a worn bearing or differential component.

- Clean around the differential cover plate seal to prevent dirt from entering the differential.
- Position a fluid drain reservoir under the differential and loosen all differential cover plate retaining bolts.
- If a drain plug exists, remove it and completely drain all differential oil from the housing.
- If no drain plug exists then the oil can be drained by loosening the cover bolts and gently prying the cover away at the bottom until oil runs out.

**HINT :** If a drain plug does not exist then it would be a good idea to drill and tap for a tapered oil drain plug to assist with future oil changes.

- Once drained, remove the differential cover plate.

## 2 Removing the Existing Differential

### 2.3 Removal of the Axles

- Remove the wheels, and brakes according to your vehicle manufacturer's service manual.
- Remove both axle shafts according to your vehicle manufacturer's service manual.

**NOTE :** The axle oil seals are delicate and can be easily damaged. Support the weight of the axle shaft when drawing them out of their sockets in the housing.

#### **IMPORTANT :**

Collision damage or heavy off-road use of your vehicle in the past may have resulted in some degree of bending in the axle. Any misalignment of the axle tubes may result in excessive wear and/or failure of your differential and axle shafts. ARB strongly recommends that you have your axle assembly inspected for concentricity and straightness before installing your *Air Locker*.



## 2 Removing the Existing Differential

### 2.4 Marking the Bearing Caps

- Using a small pointed center punch, gently mark the bearing caps in a way that will enable you to know which cap is 'LEFT' and which cap is 'RIGHT', which way is 'UP' and which way is 'DOWN'. (Fig.1.)

**HINT :** Many installers choose to make one punch mark on the left hand side of the left hand bearing cap and a similar mark on the housing at close proximity to the cap mark. The right hand side is then designated with two punch marks on the right hand side of the cap and two similar punch marks on the housing.



## 2 Removing the Existing Differential

### 2.5 Checking the Current Backlash Amount

#### **IMPORTANT:**

This step is a precautionary measure recommended by ARB due to the fact that some after market ring and pinion sets have been manufactured to run with different backlash settings than those specified by your vehicle manufacturer. Although ARB must recommend you set backlash according to your service manual guidelines, we also advise that you compare the backlash measurements taken here to the recommended backlash settings in your vehicle service manual. Measurements found to be outside of your service manual recommendations may indicate the need to deviate from those settings in order to achieve quiet running with a good contact mark.

Refer to your vehicle service manual or your local authorized ARB installer for more information.

- Set a dial indicator on one of the ring gear teeth. (Fig.2.)

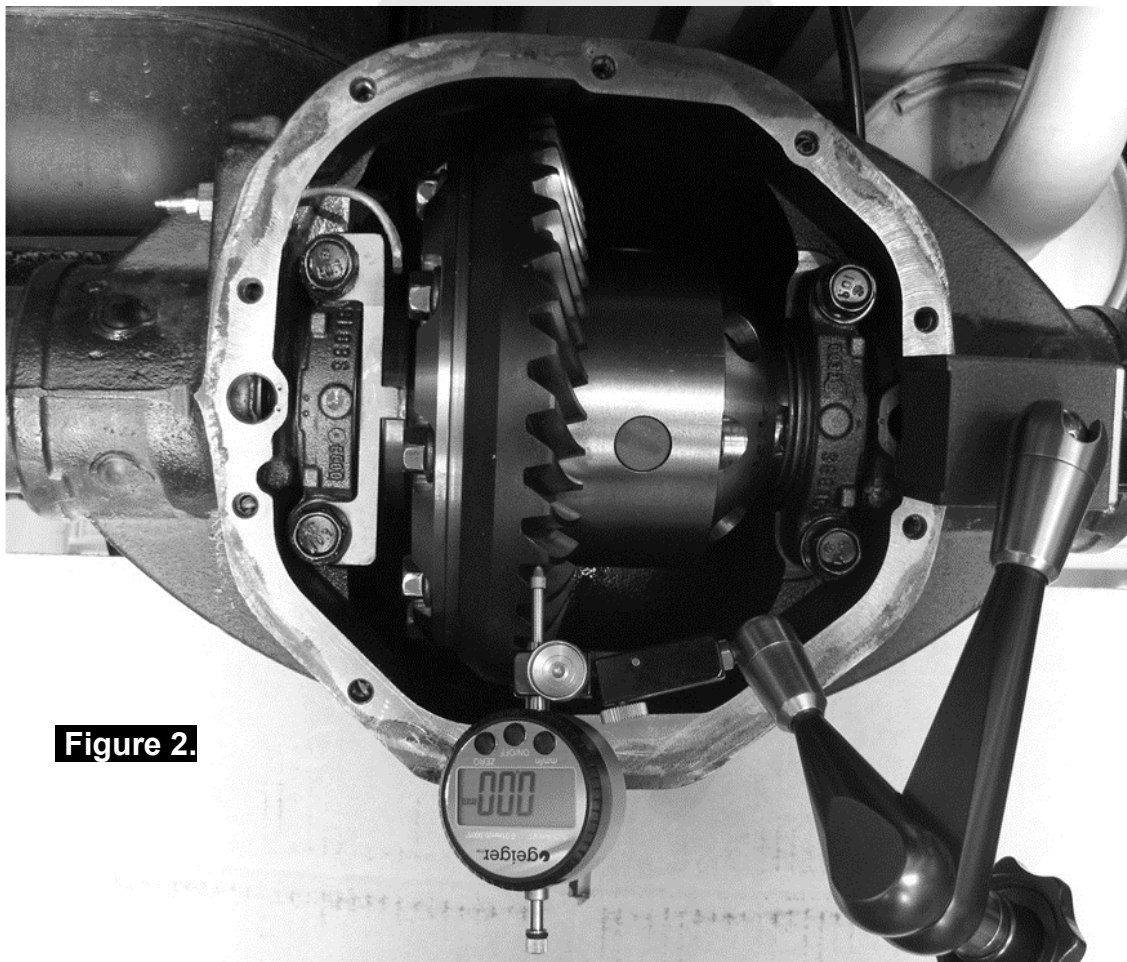

**Figure 2.**

## 2 Removing the Existing Differential

- While supporting the pinion gear by holding the pinion flange, rotate the differential in both directions while observing the maximum variation in depth from the indicator (i.e., the highest value minus the lowest value). This value is referred to as the ring and pinion backlash.
- Rotate the differential center 90° and measure again for accuracy.
- Record the average of all measurements.

### 2.6 Removing the differential carrier

#### **IMPORTANT:**

#### **YOU MUST SPREAD THE HOUSING ON CAST IRON MODELS**

**Spreading the differential housing with a differential case spreader is a step which is critical to set up bearing pre-load on cast iron differential housings (See Figure 3.). Improper pre-load will result in undue bearing wear, increased stresses in the differential center, increased running noise, and ultimately, ring and pinion gear damage.**

- Remove both bearing caps.
  - Carefully spread the housing (Fig.3.) enough to remove the differential center. (Refer to your vehicle's service manual).
- NOTE :** Do not spread the housing more than 0.50mm [0.020"].
- HINT :** Be sure not to mix up the left and right hand bearing cups. Later it will be necessary to know which cup came from which side.
- Once the housing has been adequately spread, the differential may be removed by pulling forward on the differential carrier.

## 2 Removing the Existing Differential

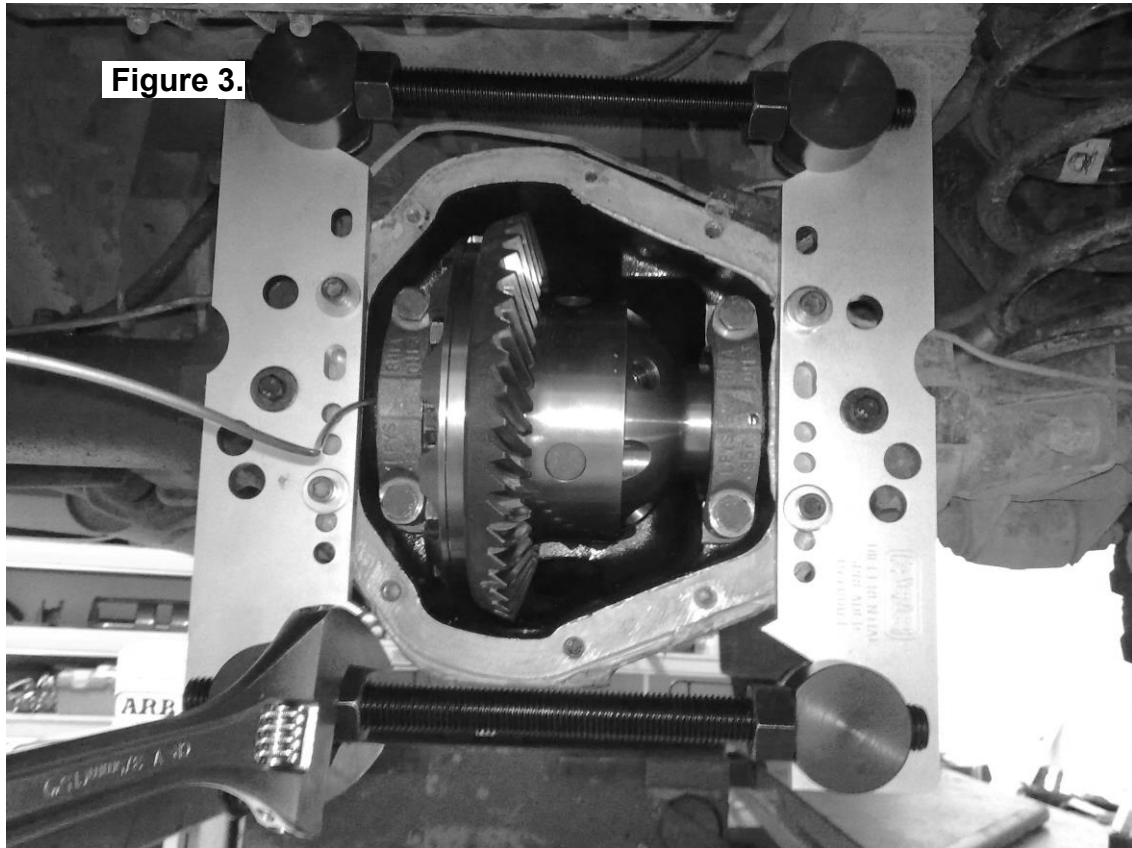

**NOTE :** The differential center is heavy and quite difficult to handle when covered in oil. Take care not to drop it.

- Relieve any tension on the spreader immediately after the differential has been removed.

### 3 Installing the Air Locker

#### 3.1 Drilling and Tapping the Bulkhead Port

An air line port must be drilled and tapped through the differential housing to mount the bulkhead fitting into.

- Cover the drive pinion and axle tube areas with a rag to protect them from metal filings.
- To find the location shown (Fig.4. & 5.) on the outside of the differential housing that will be clear of the *Air Locker* once the seal housing tube has been installed, drill a small pilot hole from the inside out as shown.

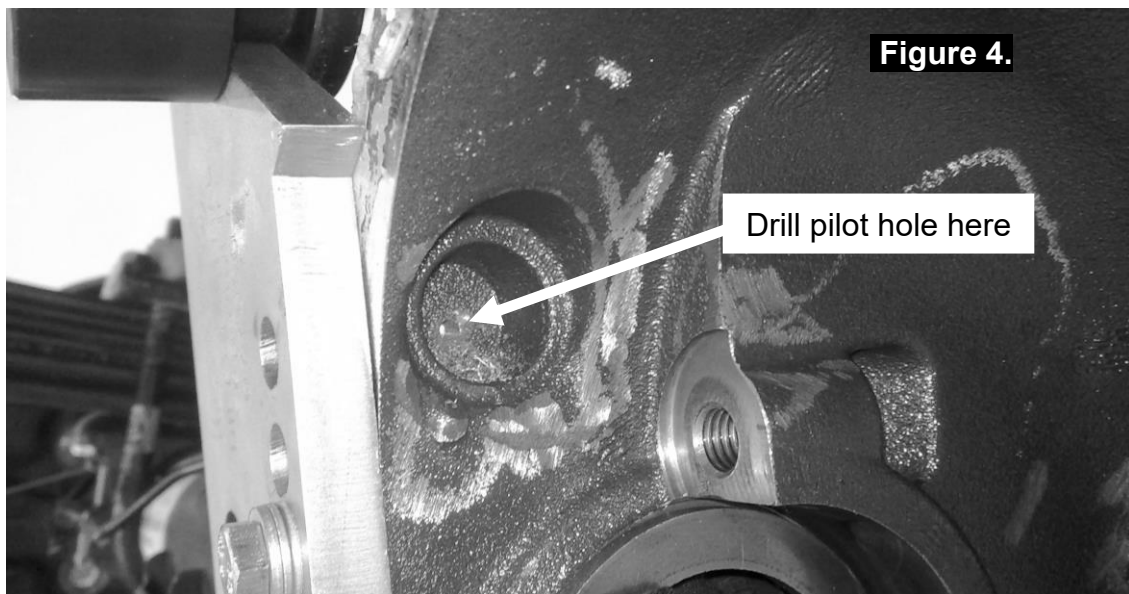

### 3 Installing the Air Locker

- Drill an 11.2mm [7/16"] diameter hole through the differential housing square to the outside surface.
- Tap the hole from the outside using ¼"NPT thread tap.
- Remove any sharp edges that may chip off from around the hole and fall into the housing.
- Very carefully, remove the rags and inspect with a service light inside the housing to ensure no metal filings are left behind.

#### 3.2 Assembling the Seal Housing

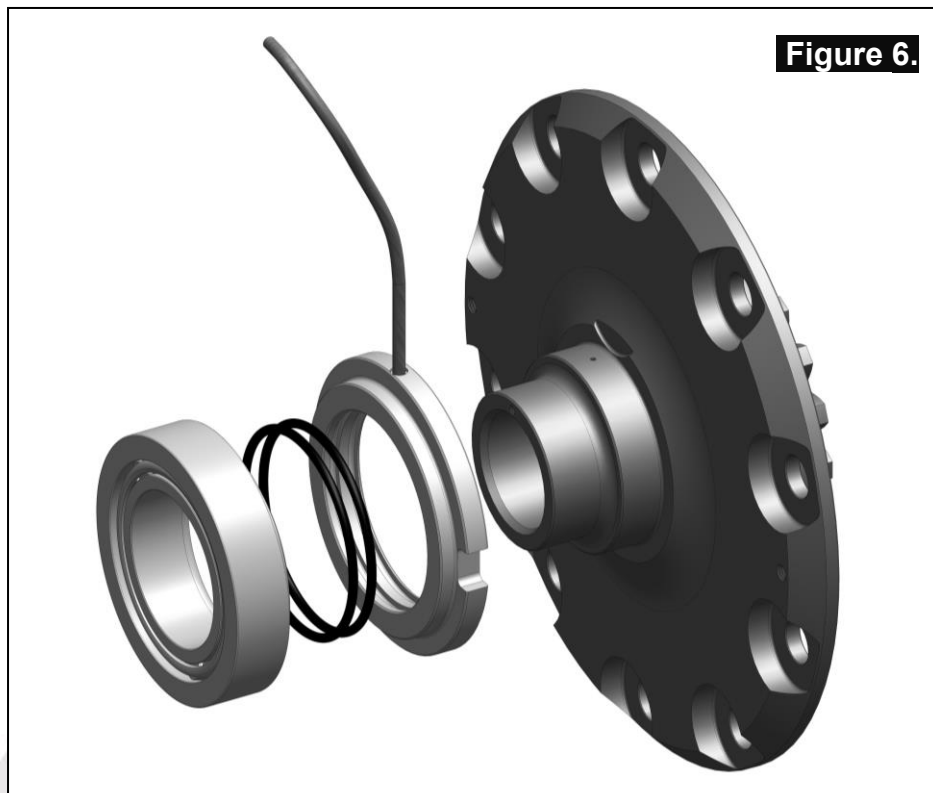

Figure 6.

- Make sure the grooves and airway of the seal housing are clean and free from any contaminants (e.g. water, dirt, metal filings, etc.).
- Inspect the seal housing O-rings (supplied) for dirt, damage or other conditions which might cause leaks.
- Generously lubricate the O-rings with oil prior to assembly, then insert them into the grooves of the seal housing.

**NOTE :** When assembling the O-rings, be careful not to leave them twisted when seated in the grooves as this could cause excessive wear and leakage.

### 3 Installing the Air Locker

- Lubricate the seal housing running surface on the *Air Locker* carrier with oil.
- Carefully install the seal housing by sliding it all of the way onto the seal housing journal with a gentle twisting motion. This will allow the O-rings to engage gently (Fig.6.).

#### 3.3 Approximate Backlash Shimming

In order to reproduce a similar preload and ring and pinion backlash in your *Air Locker* to that of your existing differential, measurements need to be taken so that a shim thickness can be calculated.

- Secure the differential to a workbench.
- Remove the bolts that hold the ring gear in place.
- Using a plastic or copper hammer, tap in a circle around the ring gear to separate it from the differential carrier.
- Remove the original bearings and shims from the differential center using a bearing puller.

**NOTE :** Keep the bearings and shims separated so that they can be identified as to which end of the differential they came from.

- Examine the bearing cups and cones from Figure 7. for damage or wear and, if necessary, discard them and replace with the same size and type of bearings.

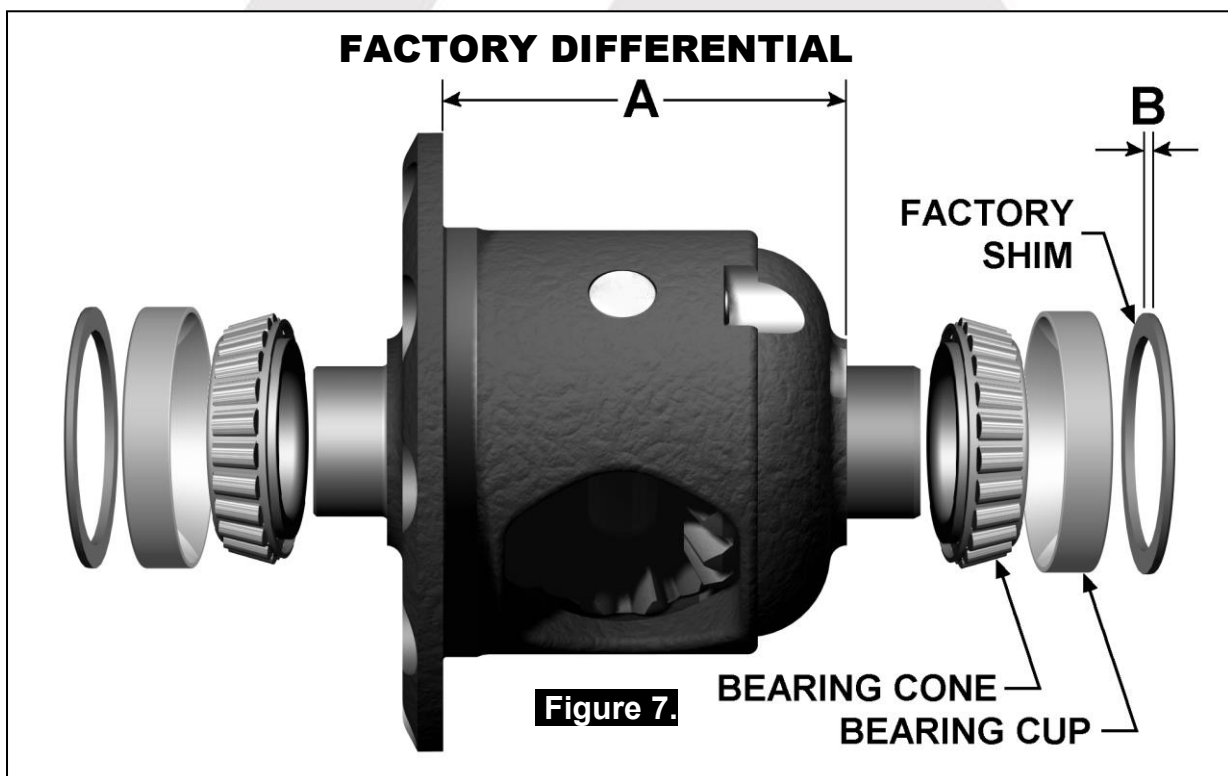

### 3 Installing the Air Locker

- Using a caliper or similarly accurate measurement method (i.e., able to take accurate measurements within 0.04mm [0.0015"]), measure the distance from the shoulder of the bearing journal to the ring gear mounting face (shown as 'A' in Figure 7.) and record this measurement as 'A'.
- Measure the thickness of the factory shim removed from the end of the differential carrier (shown as 'B' in Figure 7.) and record this measurement as 'B'.

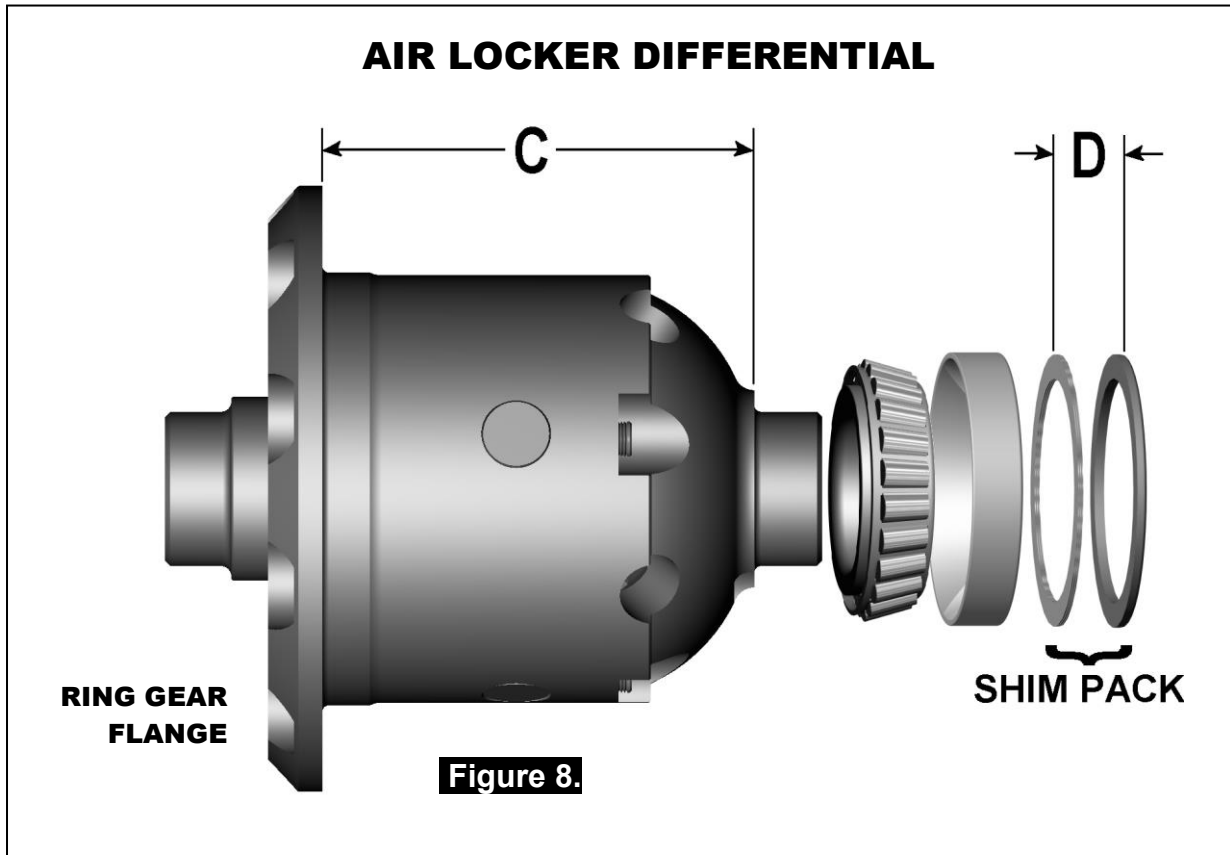

- Measure the distance from the *Air Locker* bearing shoulder to the ring gear mounting face (shown as 'C' in Figure 8.) and record this measurement as 'C'.

### 3 Installing the Air Locker

#### 3.4 Calculation & Selection of Backlash Shims

Ideally, the measurement you recorded as 'C' from the *Air Locker* differential will closely match 'A' on the existing differential (within 0.1mm [0.004"] ) and then the factory shim can be reused, however, quite often these measurements will vary slightly between one factory differential and the next.

If this is the case you must create a new shim pack thickness by using the measurements you recorded earlier to find a desired measurement for 'D' in Figure 8.

Use the following calculation:

$$A + B - C = D \text{ (Replacement Shim Pack)}$$

**HINT :** If your calculations are correct then the following calculation will also be true:

$$A + B - C - D = \text{ZERO}$$

Create a shim pack to match the thickness calculated as 'D'.

To achieve the desired shim thickness you can:

- Machine down the factory shim thickness.
- Add shims between the factory shim and the bearing cup.

**HINT :** A selection of shims of this size have been supplied with your *Air Locker* kit.

- Purchase new factory shims at the desired thickness.
- Use a universal shim kit available from most drive train specialists.
- Add small amounts of shim between the bearing cone and the bearing seat.

**NOTE :** NEVER machine the *Air Locker*.

### 3 Installing the Air Locker

#### 3.5 Installing the Carrier Bearings

- Apply a thin film of high pressure grease to the bearing journals of the *Air Locker*, then press the bearing cones onto the bearing journals as shown in Figure 9.

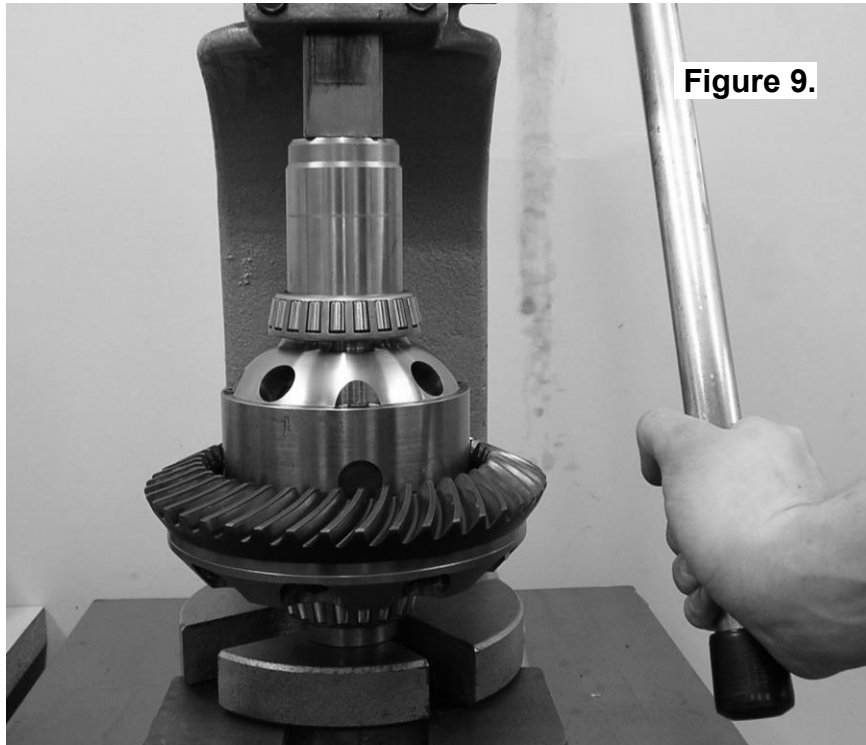

#### 3.6 Mounting the Ring Gear

- Apply a thin film of high pressure grease to the ring gear shoulder of the *Air Locker* to prevent seizing.
- Thoroughly clean any thread locking compound or other foreign matter from the holes of the ring gear, the threads of the ring gear bolts, the mating surfaces of the ring gear and the *Air Locker* flange.

**HINT :** Rubbing the ring gear mounting face with a flat oil stone before installation will remove any high spots around the threads.

- Heat the ring gear to between 80 and 100°C (175 - 212°F) in hot water or in an oven to slightly expand the gear and facilitate assembly.

### 3 Installing the Air Locker

**NOTE :** **NEVER HEAT GEARS WITH A FLAME!** This could damage the hardened surface of the gear and result in premature wear or failure.

- Dry the gear and tapped holes with compressed air (if wet).
- Install the ring gear onto the *Air Locker* by aligning the tapped holes and then gently tapping it around in a circle with a soft mallet or hammer. Avoid using the bolts to pull the ring gear down as this puts excess strain on the bolts and the differential flange.
- Apply a thread locking compound to the thread of each ring gear bolt before inserting it. Do not apply locking compound directly into the threaded hole as this could prevent the bolt from reaching its full depth.

**NOTE :** On some models, the crown wheel bolts cannot be reused and should therefore be replaced. Refer to your vehicle manufacturer's service manual for details.

- Tighten the ring gear bolts in a star pattern with a torque wrench (Fig. 10.) set to your vehicle manufacturer's specified torque.

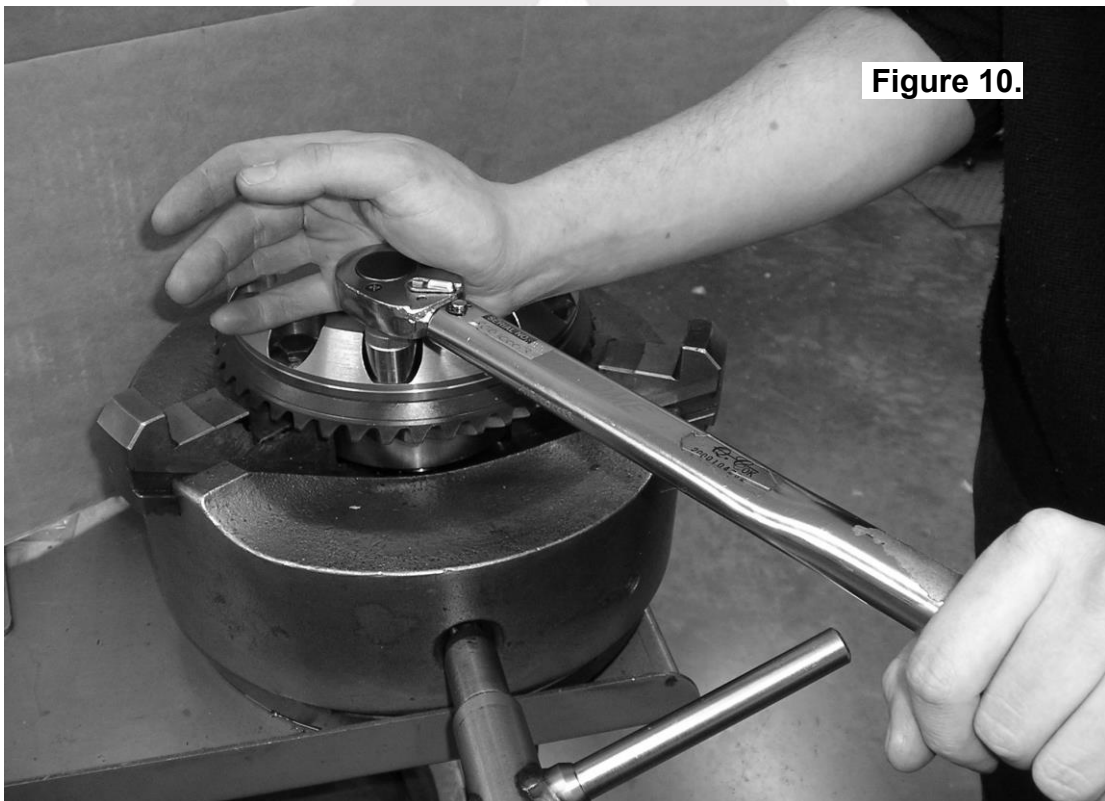

**Figure 10.**

#### 3.7 Preload Shim Measurement

### 3 Installing the Air Locker

In order to preload the tapered roller bearings in your *Air Locker*, measurements need to be taken so that a value can be calculated for the total shim thickness 'E' in Figure 11.

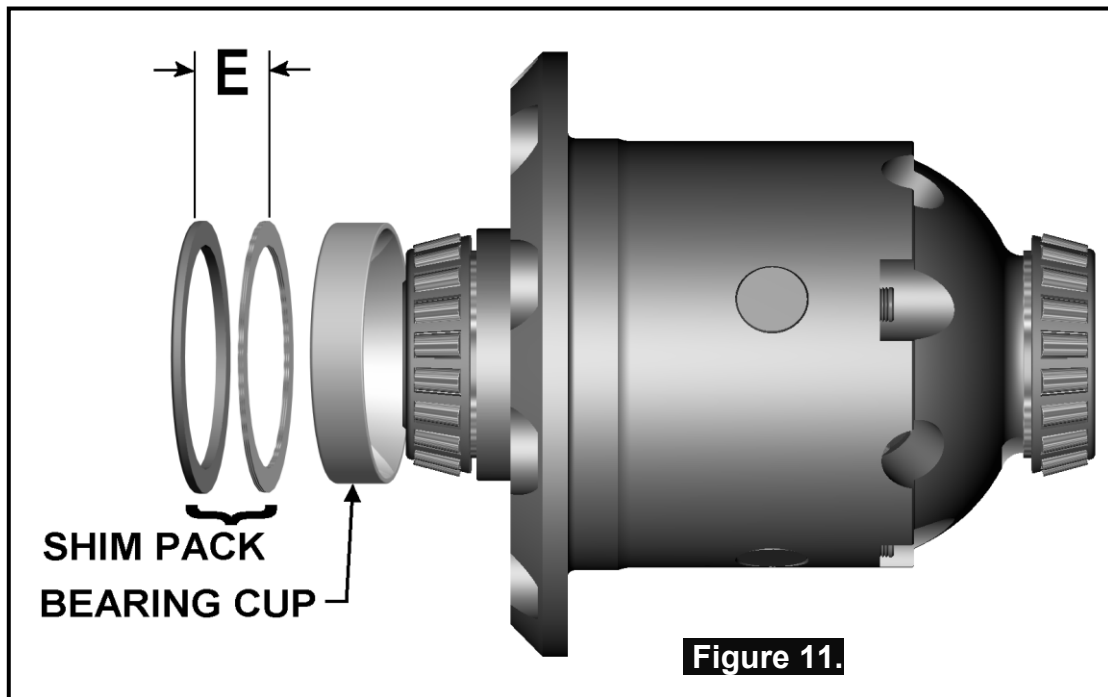

Figure 11.

- Hold the bearing cups in place over their matching bearing cones.
- Insert and hold the *Air Locker* into the differential housing.
- Insert the shim pack determined earlier as 'D' between the bearing cup and the differential housing (right hand side as shown in Fig.8.)
- Push (or lightly pry) the *Air Locker* hard across to the right-hand side, and measure the gap (also called the 'end float') between the bearing cup and the housing with a feeler gauge (See Fig 12.).
- Record this measurement.
- Consult your vehicle manufacturer's service manual to determine the carrier bearing preload amount specified for your vehicle.

**NOTE :**

**If your service manual specifies preload in terms of a torque value measured off the drive pinion flange, then assume a preload amount of 0.25mm [0.01"] for the following calculations. Once you have assembled the housing to check the final backlash (Refer to Section 3.12 *Checking the Backlash*) you should verify that your preload is correct using a torque wrench and your service manual's table of values.**



### 3 Installing the Air Locker

Figure 12.

- Add the specified preload amount to the end float measurement determined with the feeler gauge to determine a shim amount for 'E' (Refer to Figure 11.).

**PRELOAD + END FLOAT = SHIM PACK**

- Create a shim pack 'E' to closely match the calculated amount.

To achieve this desired shim thickness you can:

- Machine down the factory shim thickness.
- Add shims between the factory shim and the bearing cup.
- Purchase new factory shims at the desired thickness.
- Use a universal shim kit available from most drive train specialists.

**NOTE :** Do not add shims between the bearing cone and the bearing seat and NEVER machine the *Air Locker*.

#### 3.8 Setting up the Bulkhead Fitting

### 3 Installing the Air Locker

- Apply thread sealant to the outside threads of the bulkhead body.
- Screw the bulkhead body into the tapped hole, and lightly tighten using a 14mm [9/16"] spanner.
- Wipe the area clean of any excess thread sealant (inside and outside of the housing).
- Without using sharp, jagged tools such as pliers (your hands are the best tool for this job), bend the seal housing tube to approximate the finished profile. This will allow the tube to be trimmed to a length that would allow it to protrude from the bulkhead fitting. (Fig.13.)

**NOTE :** Use an automotive brake line tubing cutter to cut the seal housing tube. Never a hacksaw as this will leave metal filings in the air system.

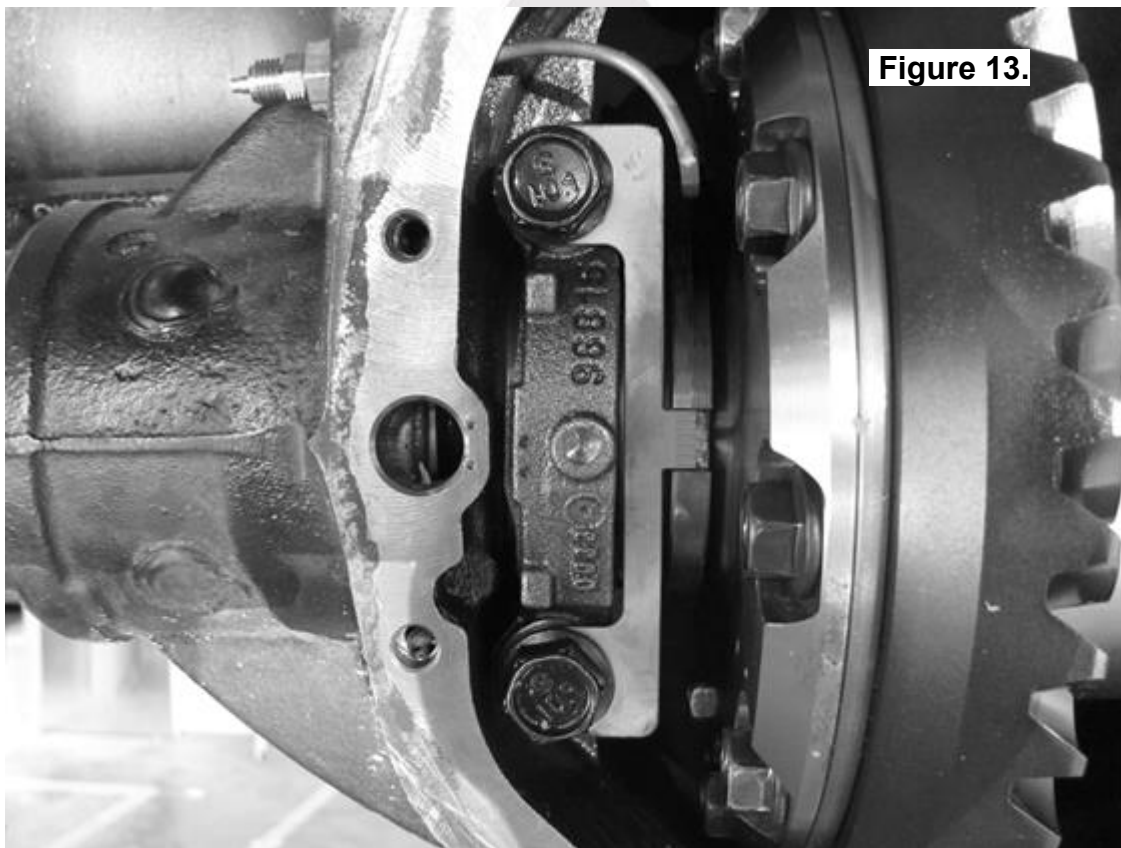

- Insert the free end of the seal housing tube into the bulkhead fitting until it protrudes approximately 8mm [5/16"] through the other side.

### 3 Installing the Air Locker

- From the outside of the housing, assemble one of the small O-rings over the top of the short length of seal housing tube protruding through the bulkhead fitting.
- Install the brass spacer.
- Install the second small O-ring after the spacer.
- While holding the seal housing tube into the bulkhead fitting, insert the chamfered end of the center compression nut over the extended tube as shown in the assembly diagram (Fig. 14.), and screw it into the bulkhead body, and tighten using Pozidriv #3 screwdriver.

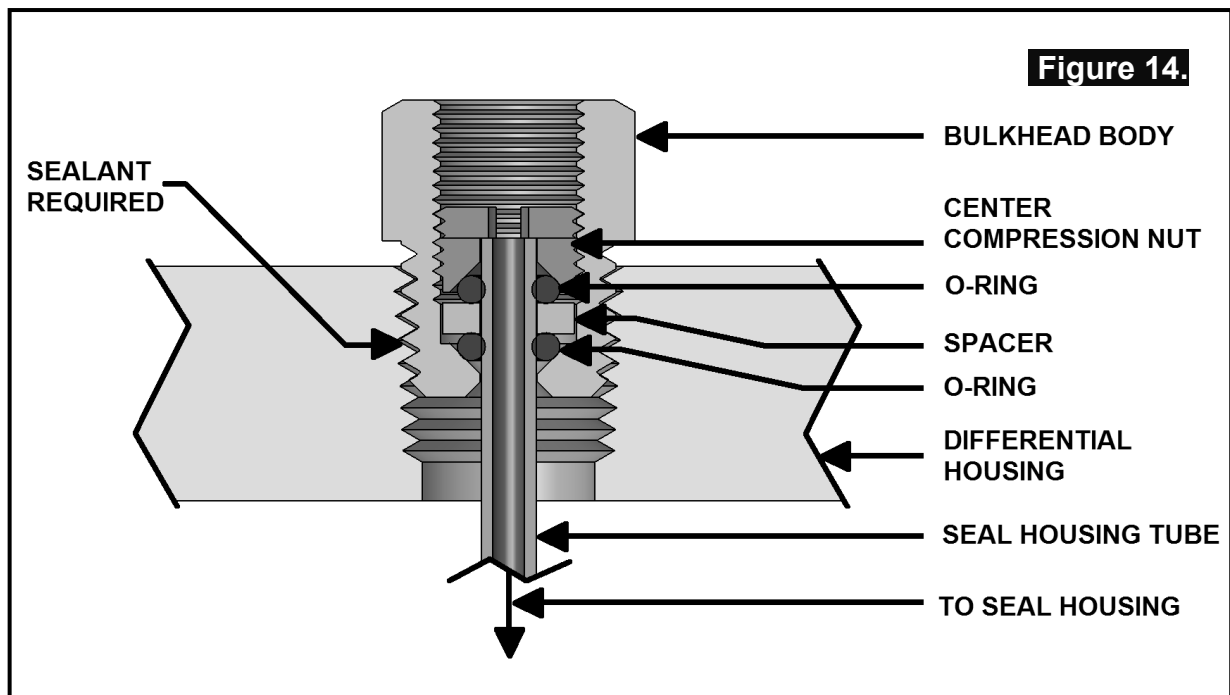

**NOTE :** Make sure the seal housing tube is all of the way into the center compression nut while you are tightening it.

**NOTE :** Firmly tighten the center compression nut so that a good seal is formed around the tube.

#### 3.9 Profiling the Seal Housing Tube

### 3 Installing the Air Locker

- With the seal housing tube now firmly secured into the bulkhead fitting, bend the tube so that it closely follows the profile of the differential without interfering with the bearing cap, diff housing or *Air Locker* (Fig. 15.).

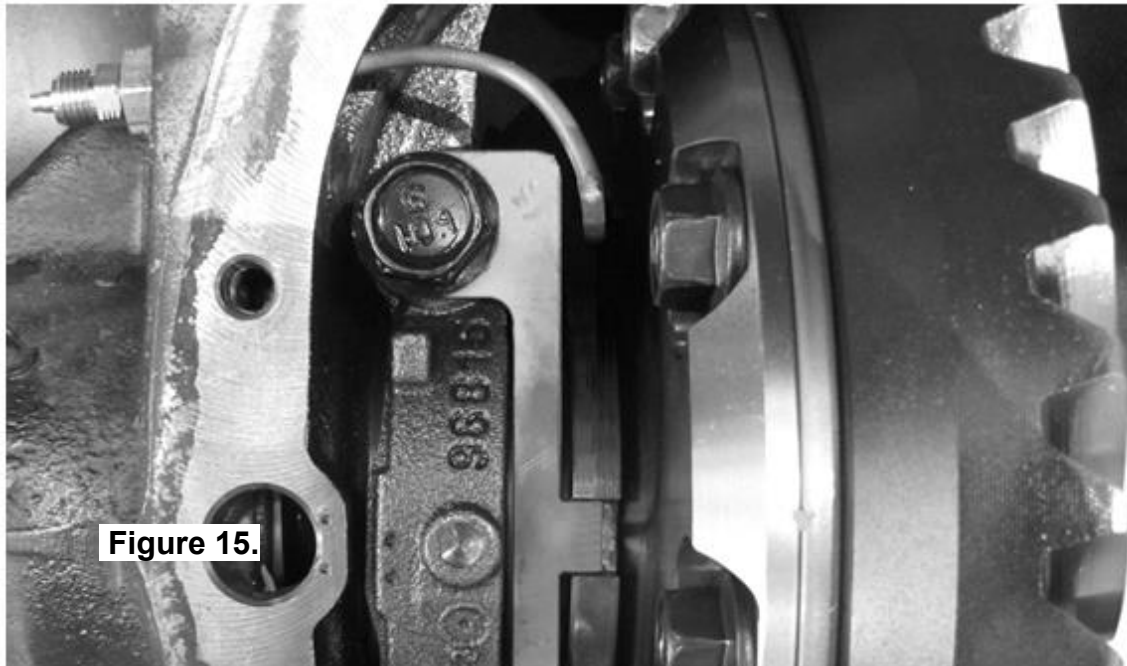

#### 3.10 Bench Testing the Air Locker

### 3 Installing the Air Locker

- To test the *Air Locker*, when 620kPa [90 PSI] shop air is applied to the seal housing tube, the *Air Locker* should engage.
- Check all fittings and the seal housing for air leaks.
- Rotate the differential carrier by turning the pinion flange whilst applying air pressure.

**NOTE :** An accurate way to test for air leaks is to fit a shut-off valve to an air pressure gauge (Available as ARB part #0770005). Charge with shop air until 620 KPA [90 PSI] is reached, shut the valve off, disconnect the air hose, and watch to see if there is any drop in pressure. Any gradual pressure drop indicates an air leak. (Fig. 16.)

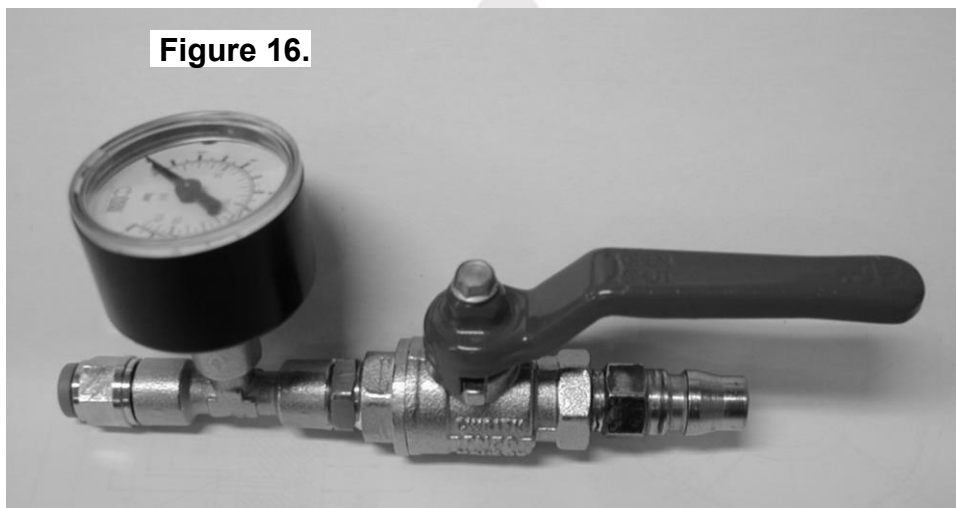

- If a leak is found to be present, spray a soap and water mixture onto the bulkhead air fitting. Bubbles should appear at any leak points.

**NOTE :** Do not spray this soapy mixture inside the differential.

- Check that leaky fittings have been adequately tightened.
- Disassemble, clean threads, and reapply thread sealant if leaking persists.
- If a leak is found at the seal housing, carefully remove and refit. Be very careful with the O-rings and check they have not been damaged during installation.

## 3 Installing the Air Locker

### 3.11 Reinstalling Differential and Axles

- Install the axles and cover plate as detailed in your vehicle service manual.

**NOTE :** Be careful not to damage the axle shaft oil seals when installing the axle. Support the axle's entire weight where possible.

- Torque down the axle bolts to manufactures specifications.

### 3.12 OE Diff Lock Replacement

Fitting the *Air Locker* will render the factory Diff Lock switch unusable, and may cause warning lights to appear on the dashboard or issues with the traction control system.

ARB recommends speaking to your authorized VW dealer and having the OE Diff Lock electronically removed from the vehicles ECU. This is a process that can be reversed at any time in the future, should the customer wish.

## 4 Installing the Air System

### 4.1 Mounting the Solenoid

#### 4.1.1 Connection to an ARB Air Compressor (Fig. 17.)

- Remove one of the 1/8" BSP plugs from its port in the compressor tank.
- Apply Teflon paste to the 1/8" BSP nipple on the solenoid and insert it into the port and tighten. The solenoid should be rotated into a position which does not obstruct any other ports on the compressor tank.

**NOTE :** The coil and stem of the solenoid can be removed to make installation easier.

**NOTE :** The solenoid is marked with two #1 ports. If space is tight, a second solenoid can be "daisy-chained" off the first one by removing the plug from the redundant #1 port and screwing the nipple from the second solenoid into it (Fig. 17.).

**NOTE :** The solenoid exhausts compressed air through the center of the black retaining cap when the *Air Locker* is disengaged. Make sure this orifice cannot be obstructed.

- Assemble the 6mm push-in fitting into the solenoid outlet port (stamped "2") and hand tighten.

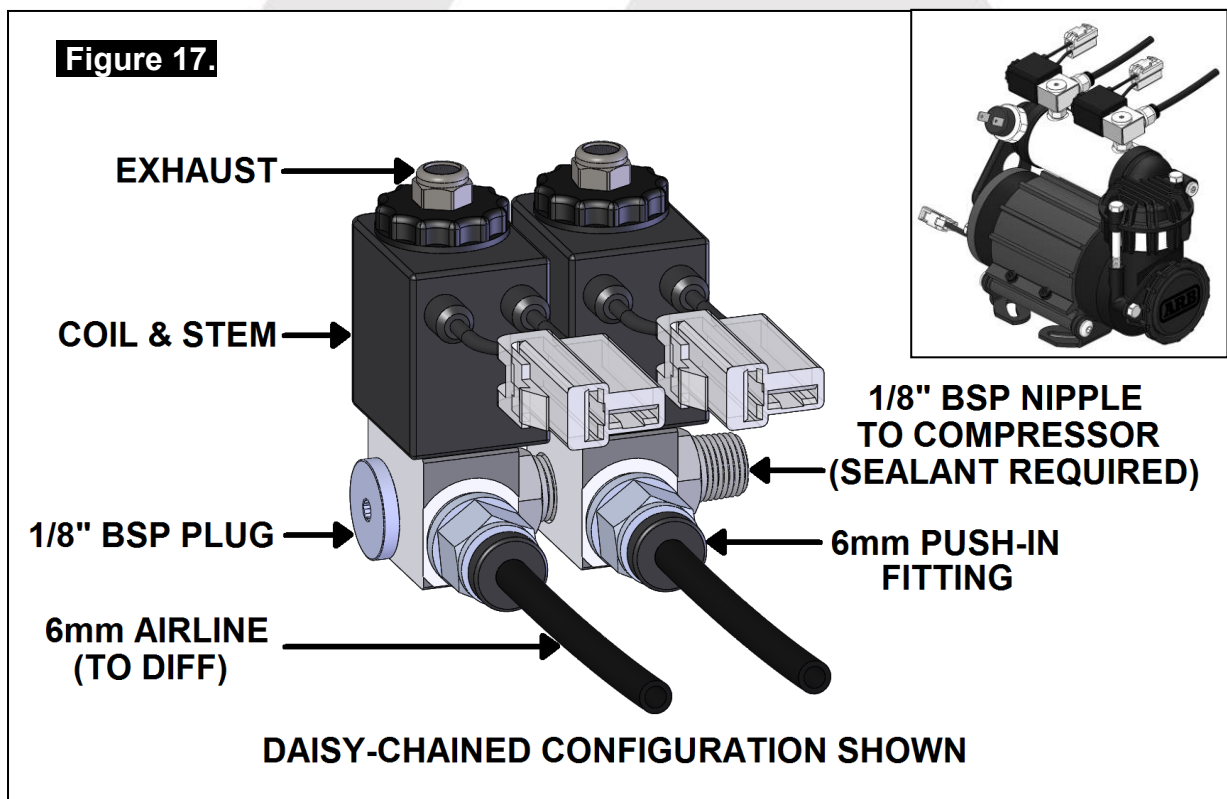

## 4 Installing the Air System

### 4.1.2 Connection to an Alternate Air Source

---

For ease of installation, quality of air supply, and a high level of dependability from your *Air Locker(s)*, ARB strongly recommends use of a genuine ARB Air Compressor, however, the *Air Locker* air system can be operated on any alternate air source that meets each of the following guidelines:

- Must supply a minimum of 586 kPa [85 PSI].
- The air source should have a tank capacity which enables it to actuate the *Air Locker(s)* in one charge so that no hesitation is experienced when locking one or two differentials.

**HINT :** A good way to insure that you have the necessary capacity is to make sure you can engage, disengage, and then reengage your *Air Locker(s)* without the air source having to regenerate (e.g., without the compressor turning on to refill the tank).

- Must supply clean air, free of rust, dirt, water, or other foreign matter.
- Must match the 1/8" BSP porting of the *Air Locker* solenoid.
- Mount solenoid within close proximity of the air supply and secure it from the effects of vibration and shock.
- Connect the air supply to the 1/8" BSP inlet port of the solenoid (stamped "1" on the solenoid body) using thread sealant.

#### **IMPORTANT :**

**ARB cannot warrant your *Air Locker(s)* against damage caused as a result of using an alternate air supply. If you have any doubts as to the suitability of your air system to use in an *Air Locker* system, consult your ARB distributor.**

## 4 Installing the Air System

### 4.2 Running and Securing the Air Line

The path taken by the air line from your air source (i.e., compressor) to your *Air Locker* is unique to your vehicle and the position of your air source. Plan ahead carefully when running the air line and always follow these guidelines:

- Account for axle travel when running the line from the axle to a fixed point on the vehicle. Leave enough slack in the air line to allow for maximum suspension travel in both directions.
- Avoid leaving large lengths of air line hanging underneath the vehicle where they may get tangled on rocks, sticks, etc.

**HINT :** **Cable tying the air line to one of your flexible brake lines will account for axle travel and should help keep your line from getting snagged.**

- Run the air line all the way from the compressor to the differential before trimming either end of the line to length. This will save complications that may arise if the air line has to be removed.
- Make sure the line does not contact sharp edges or abrasive surfaces that may damage the air line over time.
- Do not run the air line around tight bends that may kink the air line and restrict or block the air flow.
- Keep the air line well away from your vehicle's exhaust components. Air lines will melt if subjected to extreme heat.
- Do not run more air line than necessary. Excess line volume created when coiling the left over hose, using unusually large diameter hose, etc., will increase drain on the compressor tank resulting in the compressor running more often than needed.
- Support the air line by tying it back with cable ties wherever possible.
- At the solenoid end of the air line, trim the line to length with a sharp knife.
- To attach the air line to the push-in fitting of the solenoid; insert the line firmly into the fitting, pull outward on the flange of the fitting while holding the line as far into the fitting as possible, and then gently pull outward on the air line to clamp the line in place.

## 4 Installing the Air System

**NOTE :** To remove the air line from the push-in fitting; push the air line as far into the fitting as possible and hold, push inward on the flange, and then pull the air line free of the fitting.

### 4.3 Connection to the Bulkhead Fitting

- Trim the air line to length using a sharp knife.
- Assemble an aluminium washer onto the banjo bolt and insert through the banjo fitting. Assemble second aluminium washer and tighten into bulkhead fitting using a 14mm [9/16"] spanner. (Fig.18.)
- Apply thread sealant to the tapered thread of the compression fitting body and screw into the banjo fitting. Tighten using a 12mm spanner.
- Insert the outer compression nut and ferrule over the air line. Ferrule should be orientated as per Fig.18.

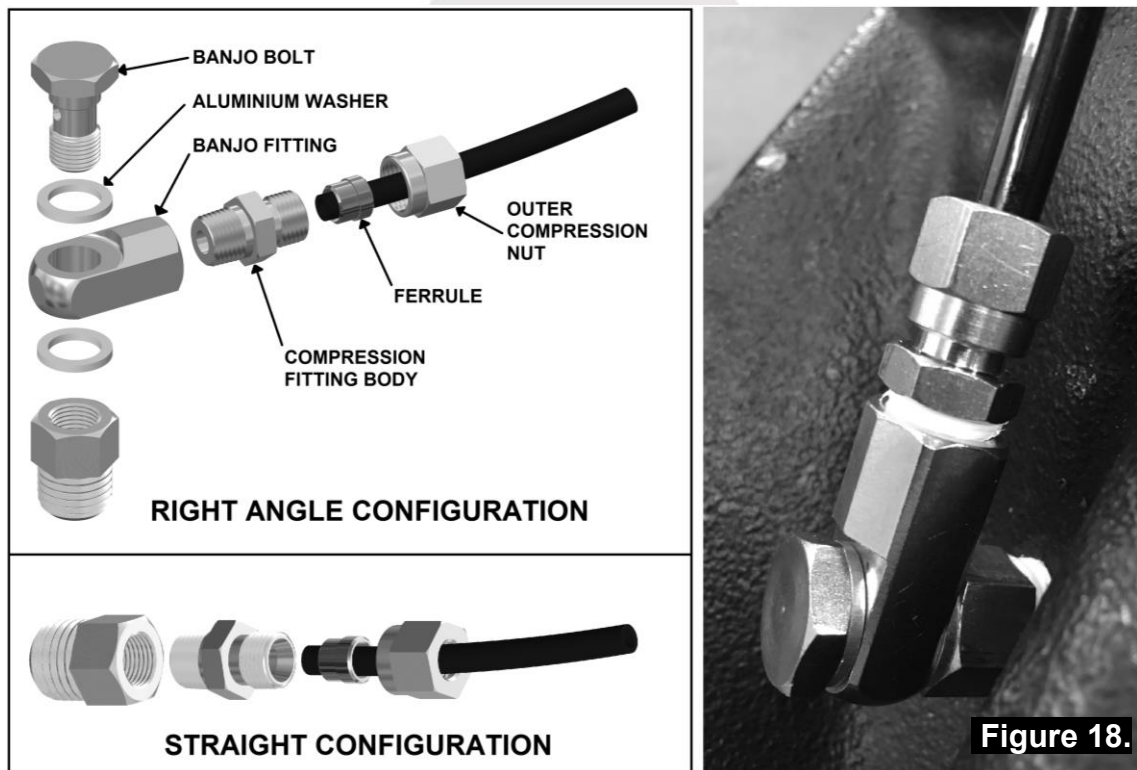

## 4 Installing the Air System

- Push the airline into the compression fitting body and screw the outer nut down onto it. Using a 12mm spanner, tighten the outer nut onto the compression fitting body.

**NOTE :** Some force is required to crush the ferrule, however the outer compression nut will tighten against a stop. Over tightening will not create a better seal.

- Secure any loose sections of tube with a cable tie.

**NOTE :** When right angle routing of the tube is not required, screw the compression fitting body straight into the bulkhead fitting body (Fig.18.).



## 5 Mounting & Connecting the Electrical System

### 5.1 Mounting the Actuator Switch(es)

*Air Locker* actuator switch(es) can be easily panel mounted inside the vehicle in a 21mm x 36.5mm [0.83" x 1.44"] rectangular cutout.

**NOTE :** Only attach the cover plate to the face of the switch once the switch has been mounted and wired correctly as the cover plates are designed to be difficult to remove.

For reasons of safety and for ease of operation, the *Air Locker* actuator switch(es) should be mounted in a location picked to best suit the operator. Make sure you have taken the following points into consideration:

- Switch(es) MUST be mounted and should never be allowed to simply dangle from the wiring loom during vehicle use.
- Switch(es) should be within easy reach of the driver. Ideally, any *Air Locker* switch should be able to be operated without physical effort or distraction to the driver.
- Switch(es) should be mounted within the line of sight of the driver so that switch position ('ON' or 'OFF') can be visually determined by the rocker position and the illumination state.
- The position of the switch(es) should best eliminate any possibility of accidental operation by the driver or one of the passengers.
- Switch cutout position(s) must be located in an area with a minimum of 50mm [2"] of clearance behind the face of the cutout.
- Switch(es) should not be mounted where they will be exposed to water (e.g., in the lower section of an inner door panel).
- ARB recommends that you apply the *Air Locker* Warning Sticker (ARB part # 210101) within close visual proximity of the switch location.

**NOTE :** If no adequate position can be found on existing dashboard panels, a surface mounted bracket (Fig.19.) may be purchased from your ARB *Air Locker* distributor to suit 1, 2, or 3 switches.

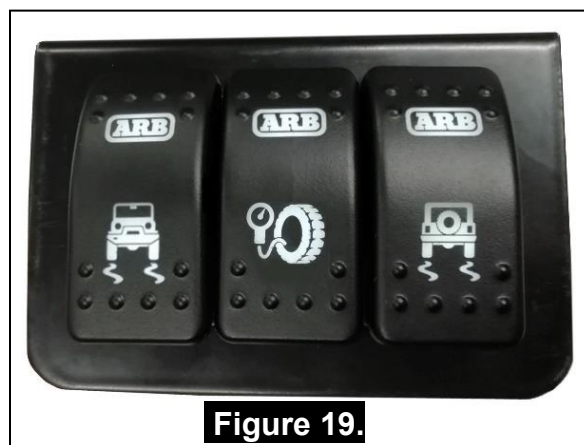

# 5 Mounting & Connecting the Electrical System

## 5.2 Wiring the Actuator System

### 5.2.1 Connection to an ARB AIR COMPRESSOR

When wiring the *Air Locker* actuator switch(es) and solenoid(s) to an ARB Air Compressor, all connections can easily be set up directly from the supplied wiring loom. (Fig. 20.)

**NOTE :** 180409 model loom shown for reference only. Refer to your ARB Air Compressor Installation Guide for details on configuring your installation.

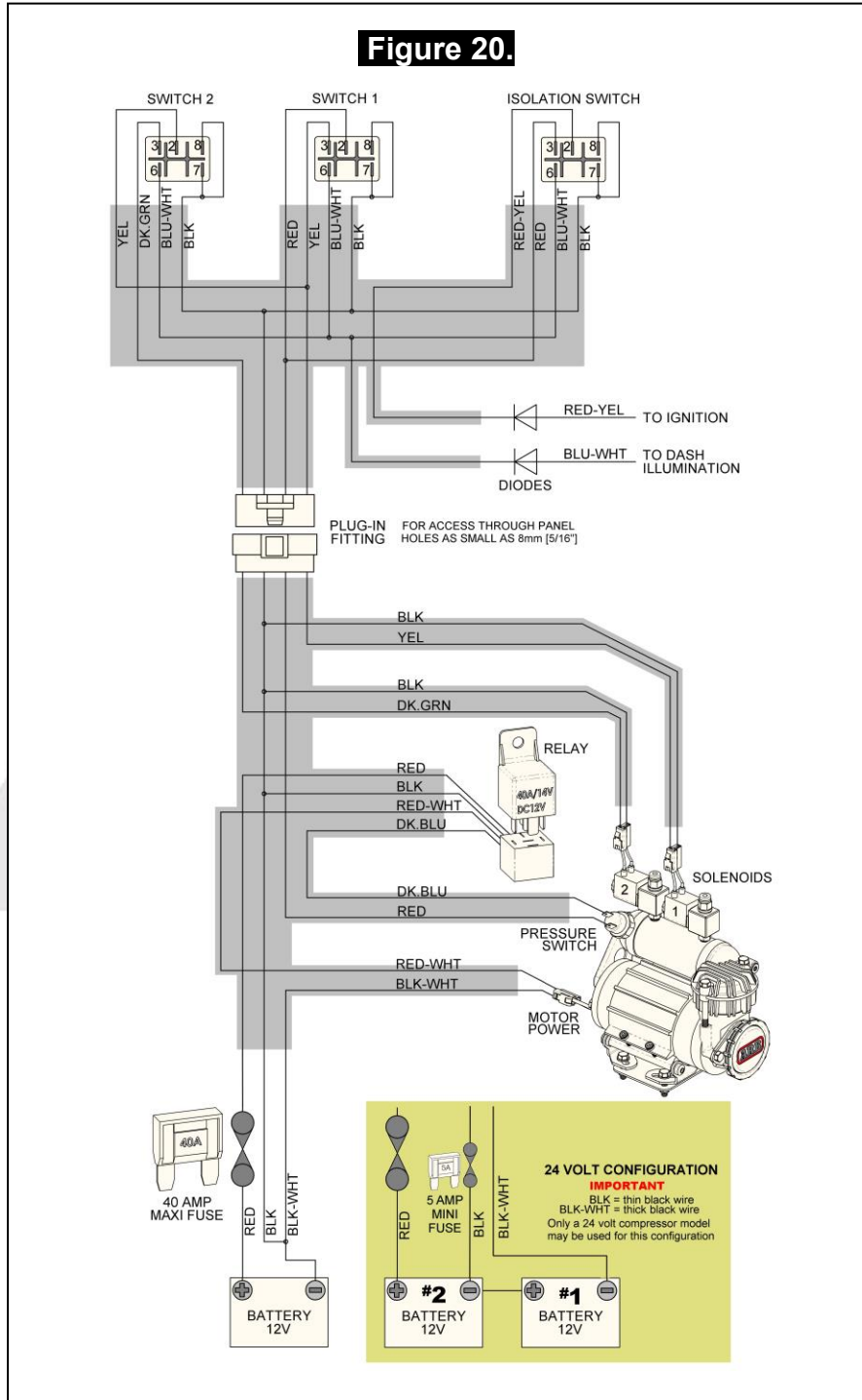

## 5 Mounting & Connecting the Electrical System

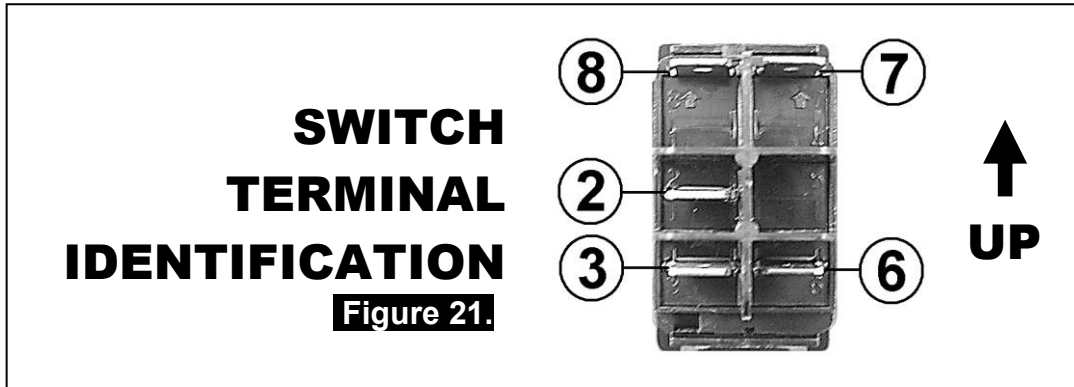

### 5.2.2 Connection to an Alternate Air Source

When connecting the actuation switch to an alternate air source, the switch(es) should be wired according to figures 22. and 23. depending on whether one or two *Air Lockers* will be installed in the vehicle.

#### 5.2.2.1 Single Air Locker System

- If only one *Air Locker* is to be installed in the system, the switch and solenoid should be wired according to figure 22. regardless of whether the Air Locker has been installed in the front or rear axle of the vehicle.
- Attach the appropriate switch cover (i.e., 'FRONT' or 'REAR') to the switch.

**NOTE :** Refer to figure 21. for the correct switch terminal identification and switch orientation.

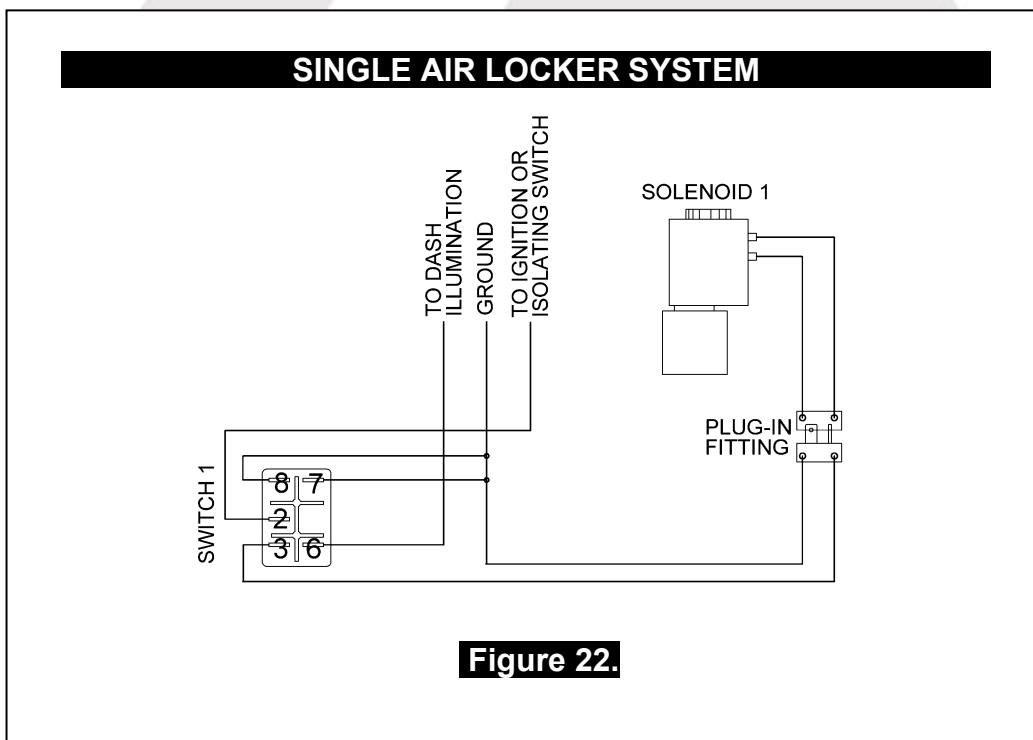

## 5 Mounting & Connecting the Electrical System

### 5.2.2.2 Dual Air Locker System

- If two *Air Lockers* are to be installed in the system, ARB recommends that the switches and solenoids be wired according to figure 23. For safety reasons, this configuration allows SOLENOID 2 to be actuated only if SOLENOID 1 is already on.
- Attach the “REAR AIR LOCKER” switch cover to SWITCH 1, and the “FRONT AIR LOCKER” switch cover to SWITCH 2.

**NOTE :** Refer to figure 21. for the correct switch terminal identification and switch orientation.

- Configure SOLENOID 1 as the air line leading to the rear axle *Air Locker*, and SOLENOID 2 as the air line leading to the front axle *Air Locker*.

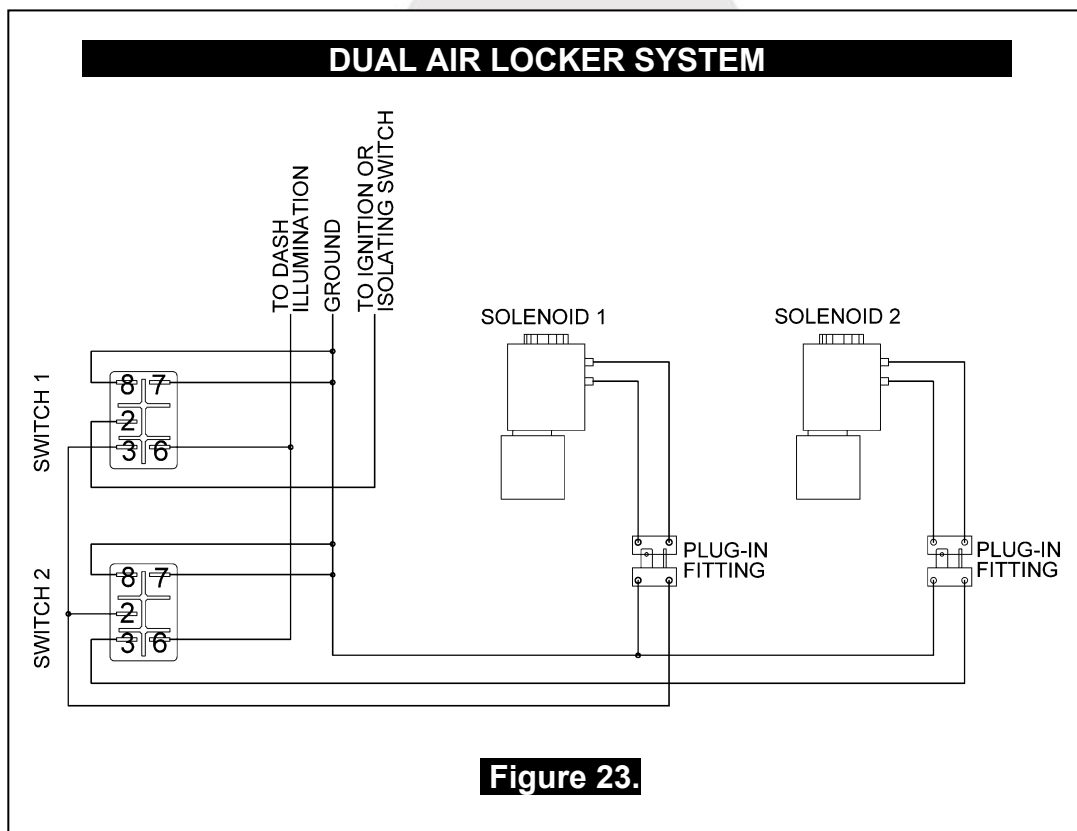

## 6 Testing & Final Assembly

### 6.1 Leak Testing

- With the vehicle parked and the engine off, turn the compressor on and wait until the air system is fully charged.

**NOTE :** With the *Air Locker(s)* disengaged, the air source (i.e., compressor) should not have to recharge over time. Intermittent recharging without *Air Locker* use usually indicates a leak at the solenoid fittings or at the compressor tank O-ring seal.

- Actuate the *Air Locker(s)*.
- The compressor should not come on again for a period of at least 15min. Air system recharging within that time period would indicate that a leak is present in the system.

**NOTE :** If an alternate air source (e.g., an air cylinder or a belt driven air pump) is used instead of a compressor, the air system will have to be leak tested with a pressure gauge and a shut-off valve in series before the solenoid input. (Fig.16.)

- If a leak is found to be present, spray a soap and water mixture onto all air fittings in the system while the compressor is fully charged. Bubbles should appear at any leak points.
- Check that leaky fittings have been adequately tightened.
- Disassemble, clean threads, and reapply thread sealant if leaking persists.

### 6.2 Testing the Air Locker Actuation

To test that your air system, electrical system, and your *Air Locker* differential is functioning correctly:

- Support the vehicle such that the wheels are free to rotate (e.g., on axle stands, a chassis hoist, etc.)
- Leave the parking brake off, the transmission in neutral, and the *Air Locker* switch 'OFF'.
- Turn the ignition to the 'ON' position (leaving the motor off). The large illuminating symbol on the *Air Locker* switch cover should be 'OFF'.

## 6 Testing & Final Assembly

- Turn the compressor (or alternate air source) on to charge the air supply up to its maximum pressure.
- Rotate one wheel by hand.
- The wheel should rotate freely and the opposite wheel should be turning in the opposite direction without any resistance or mechanical noise from within the differential.
- Turn the *Air Locker* switch to the 'ON' position. The illuminated symbol on the switch cover should light up.
- Rotate the same wheel again.
- Both wheels should rotate together.
- Turn the switch off again.
- Rotate the same wheel.
- The wheels should again rotate in opposite directions.

### 6.3 Filling the Differential

**NOTE :** Consult the *ARB Air Locker Operating & Service Manual* for recommendations on differential lubricant specifications.

- Refill the differential until level with the filler hole.
- Rotate the differential center 2 full turns.
- Check the oil level and add oil if necessary.
- Apply thread sealant to filler plug before inserting.
- Replace the filler plug.
- Clean the differential housing of any oil or grease that may collect dirt or other abrasive particles.

## 6 Testing & Final Assembly

### 6.4 Post-Installation Check List

Now that the *Air Locker* installation has been completed, ARB recommends that you take the time to complete the following check list just to insure that you haven't missed any of the vital steps.

- The air system has been leak tested.
- Thread locking compound was used on the ring gear bolts.
- All torque settings comply with the vehicle manufacturer's specs and were set with an accurate torque wrench.
- Differential fluid complies with ARB recommendations and has been filled to the correct level.
- All air lines and wiring have been securely cable tied to resist snagging.
- Switch(es) have been securely mounted within operator reach, yet well away from danger of accidental engagement.
- Switch(es) function properly and illuminate to indicate *that Air Locker(s)* are engaged.
- All operators who are to use the *Air Locker* have read, and fully understand the *ARB Air Locker Operating & Service Manual*.
- The *Air Locker* Warning Sticker has been located within close proximity of the actuator switch(es).

INSTALLATION PERFORMED BY: \_\_\_\_\_

DATE OF INSTALLATION: \_\_\_\_\_

ODOMETER READING: \_\_\_\_\_

ARB AIR LOCKER SERIAL No.: \_\_\_\_\_



## 7 Parts List

**RD198**

VW Amarok Rear

### 7.1 Exploded Assembly Diagram

(See itemized parts list overleaf)

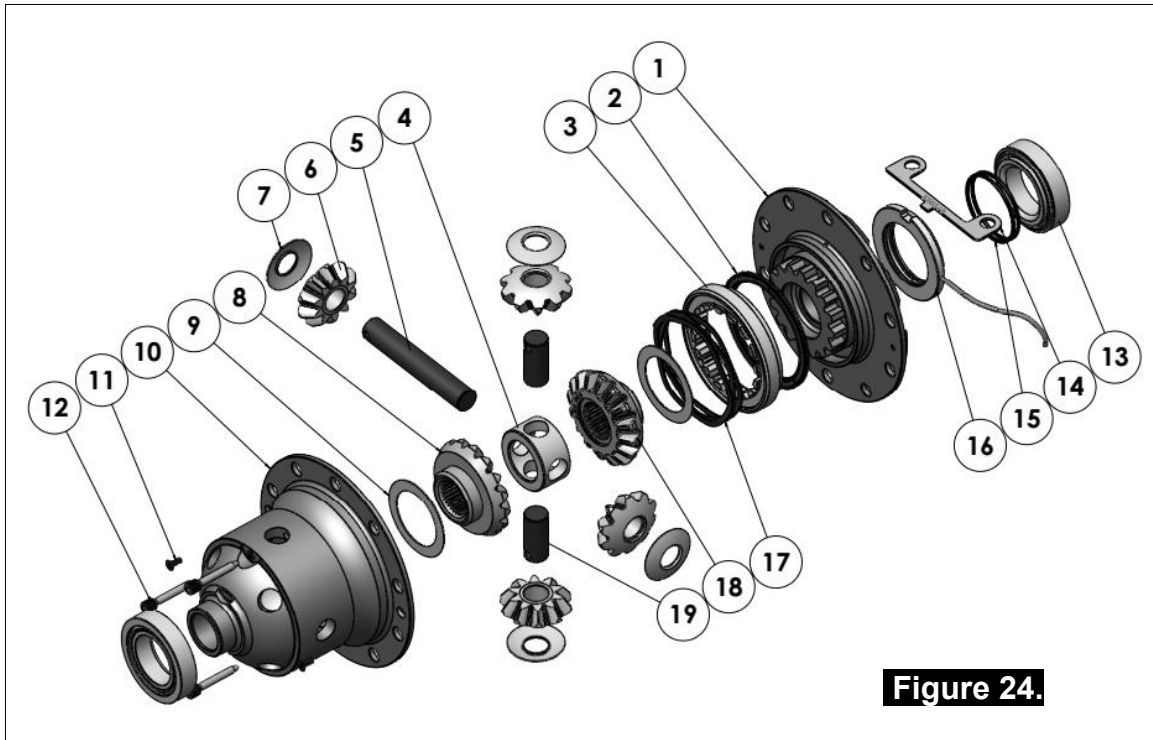

**Figure 24.**

### 7.2 Specifications

Axle Spline	30 tooth, Ø33.3mm [1.31"]
Ratio Supported	All
Ring Gear ID	143.4mm [5.64"]
Ring Gear OD	226.0mm [8.9"]
Ring Gear Bolts	10 bolts on Ø170.0mm [6.69"]
Ring Gear Torque	108Nm [80 ft-lb]
Backlash	0.12-0.18mm [0.003-0.005"]
Bearing Cap Torque	88Nm [65 ft-lb]

## 7 Parts List

### 7.3 Itemized Parts List

(See exploded diagram Figure 24.)

ITEM #	QTY	DESCRIPTION	PART #	NOTES
01	1	FLANGE CAP KIT	027330SP	
02	1	BONDED SEAL	160702SP	
03	1	CLUTCH GEAR & WAVESPRING KIT	050901SP	
04	1	SPIDER BLOCK	070201SP	
05	1	LONG CROSS SHAFT	060204SP	
06	4	PINION GEAR	SEE NOTE	2
07	4	PINION THRUST WASHER	SEE NOTE	3
08	1	SIDE GEAR	SEE NOTE	2
09	2	SIDE GEAR THRUST WASHER	SEE NOTE	3
10	1	DIFFERENTIAL CASE	013030SP	
11	1	COUNTERSUNK SCREW (PK OF 2)	200213SP	
12	1	RETAINING PIN SET (PK OF 4)	120601SP	
13	-	TAPERED ROLLER BEARING	NOT SUPPLIED	
14	1	SEAL HOUSING BRACKET	220210	
15	1	SEAL HOUSING O-RINGS (PK OF 2)	160248-2	
16	1	SEAL HOUSING KIT	081817SP	1
17	1	WAVESPRING	150701SP	
18	1	SPLINED SIDE GEAR	SEE NOTE	2
*	2	SHORT CROSS SHAFT	060403SP	
*	1	SHIM KIT	SHK008	
*	1	SEAL HOUSING BRACKET	220210	
*	1	BULKHEAD FITTING KIT (BANJO TYPE)	170114	4
*	1	AIR LINE (6mm DIA X 6m LONG)	170314SP	4
*	1	SOLENOID VALVE (12V)	180103	
*	1	SWITCH RR LOCKER	180224SP	
*	1	CABLE TIE (PK OF 25)	180305	
*	1	OPERATING & SERVICE MANUAL	210200	
*	1	INSTALLATION GUIDE	2102198	

\* *Not illustrated in exploded view*

### NOTES

- 1 For replacement O-rings use only BS140 Viton 75.
- 2 Available only as complete 6 gear set # 728H051
- 3 Available only as complete thrust washer kit #730H01
- 4 All diffs produced before serial #17070001 came with 5mm air connection system.  
For information contact ARB.

Part No. 2102198  
Revision 11/07/2025  
Copyright © 2015 by ARB Corporation Limited

