



---

# RD253

**TOYOTA 9.5" RR, 32 SPL,  
OE LOCKER REPLACEMENT**

---

**AIR OPERATED  
LOCKING DIFFERENTIAL  
INSTALLATION GUIDE**

---

No liability is assumed for damages resulting in the use of the information contained herein.  
ARB Air Locker Locking Differentials and Air Locker are trademarks of ARB Corporation Limited.  
Other product names used herein are for identification purposes only and may be trademarks of their respective owners.



---

# **ARB 4x4 ACCESSORIES**

## **Corporate Head Office**

**42-44 Garden St  
Kilsyth, Victoria  
AUSTRALIA  
3137**

**Tel: +61 (3) 9761 6622  
Fax: +61 (3) 9761 6807**

**Australian enquiries  
North and South American enquiries  
Other international enquiries**

**sales@arb.com.au  
sales@arb.com.au  
exports@arb.com.au**

---

**www.arb.com.au**

# Table of Contents:

<b>1</b>	<b>Introduction</b>	<b>3</b>
1.1	Pre-Installation Preparation	3
1.2	Tool-Kit Recommendations	4
<b>2</b>	<b>Removing the Existing Differential</b>	<b>5</b>
2.1	Vehicle Support	5
2.2	Differential Fluid Drain	5
2.3	Removing the Axles and Differential	5
2.4	Removing OE Locker Mechanism	5
2.5	Marking the Bearing Caps	8
2.6	Checking the Current Backlash Amount	8
2.7	Spreading the Differential Housing	10
<b>3</b>	<b>Bench Measurement</b>	<b>11</b>
3.1	Approximate Backlash Shimming	11
3.2	Calculation & Selection of Shims	13
<b>4</b>	<b>Installing the Air Locker</b>	<b>14</b>
4.1	Installing the Carrier Bearings	14
4.2	Mounting the Ring Gear	15
4.3	Assembling the Seal Housing	16
4.4	Calculation & Selection of Pre-Load Shims	17
4.5	Final Air Locker Assembly	18
4.6	Final Backlash Checking	18
4.7	Profiling the Seal Housing Tube	20
4.8	Setting up the Bulkhead Fitting	23
4.9	Bench Testing the Air Locker	24
4.10	Reinstalling the Differential and Axles	25
<b>5</b>	<b>Installing the Air System</b>	<b>26</b>
5.1	Mounting the Solenoid	26
5.2	Running & Securing the Air Line	28
5.3	Connection to the Bulkhead Fitting	29
<b>6</b>	<b>Mounting &amp; Connecting the Electrical System</b>	<b>30</b>
6.1	Rear Differential Lock Sensor Replacement	30
6.2	Wiring Modifications	31
<b>7</b>	<b>Testing &amp; Final Assembly</b>	<b>37</b>
7.1	Leak Testing	37
7.2	Testing the Air Locker Actuation	37
7.3	Filling the Differential	38
7.4	Post-Installation Check List	39
<b>8</b>	<b>Parts List</b>	<b>41</b>
8.1	Exploded Assembly Diagram	41
8.2	Specifications	41
8.3	Itemized Parts List	42



# 1 Introduction

## **IMPORTANT :**

**BEFORE ATTEMPTING TO DISMANTLE YOUR VEHICLE FOR THIS INSTALLATION, PLEASE READ THIS INSTALLATION GUIDE IN ITS ENTIRETY, AS WELL AS ALL APPLICABLE SECTIONS OF YOUR VEHICLE MANUFACTURER'S SERVICE MANUAL.**

### 1.1 Pre-Installation Preparation

This booklet is to be used in conjunction with your vehicle manufacturer's service manual. ARB endeavors to account for every possible variation in vehicle model when publishing its installation guides, and guides are updated regularly as new model information becomes available, however, the rapid and globally varied release of some vehicles makes it difficult to insure that your vehicle model has been accurately accounted for. In the case of any technical discrepancies between this guide and your service manual, we strongly advise that you adhere to the specifications and techniques as documented in your service manual.

Although your *ARB Air Locker* comes complete with all the step by step instructions you will need to supplement your vehicle manufacturer's service manual and install your new differential, ARB recommends that you have your *Air Locker* installed by a trained professional. Many ARB distributors around the world have been fully instructed in *Air Locker* installations by ARB, and have gained a wealth of experience and skill from years of performing similar installations.

Once you begin this installation your vehicle will be immobile until all steps of the installation are complete. Make sure your *Air Locker* kit is the correct model for your vehicle and that it contains all of the parts listed on back cover of this booklet. Also be sure you have appropriately equipped yourself with all the necessary tools, parts, and materials to complete this installation (see section 1.2 *Tool-Kit Recommendations*), and that you have allowed for an appropriate amount of vehicle down time.

#### **HINT :**

Place a ✓ mark inside each of the  symbols as you complete each step. It is very important NOT to miss any of the steps!

# 1 Introduction

## 1.2 Tool-Kit Recommendations

Below is a list of tools and supplies you may need to complete this installation. Requirements for your vehicle may vary. Please consult your vehicle service manual for additional recommendations.

### 1.2.1 Tools

- Standard automotive sizes (metric and/or imperial) of sockets, wrenches, Allen keys, and drills. Automotive wiring tools.
- A dial indicator or other suitable measuring tool for checking ring & pinion backlash.
- A standard automotive feeler gauge.
- Automotive brake tubing cutters to cut the copper tubing.
- A razor knife to cut the nylon tubing.
- A differential housing spreader, to facilitate removal of the carrier. (e.g., ARB Differential Spreader #0770003)
- A torque wrench. (See vehicle service manual for required torque range.)
- A lubricant drain reservoir.
- Suitable measuring tools to measure a differential for pre-load and/or backlash shimming. (See Section 3 *Bench Measurement*)
- An 11.2mm [7/16"] drill and ¼" NPT tap for bulkhead fitting installation.
- An automotive bearing puller (e.g., ARB Bearing Puller #0770001) or a differential carrier bearing puller.
- A bearing press or arbor press.
- Shim driver (e.g., ARB Shim Driver #0770004).

### 1.2.2 Supplies

- Thread lubricant/sealant compound for pressure fittings (e.g., LOCTITE #567 Teflon paste)
- Thread locking compound (e.g., LOCTITE #272)
- Either a replacement gasket, or gasket sealant.
- A sufficient volume of differential oil to completely refill your housing. (see the *ARB Air Locker Operating and Service Manual* for recommended lubricants)
- A soap and water mixture to test for air leaks.
- A selection of differential bearing shims to set-up pre-load and backlash. (See section 3 *Bench Measurement*)

## 2 Removing the Existing Differential

### 2.1 Vehicle Support

- Safely secure the vehicle on a hoist. We recommend supporting the vehicle on a chassis hoist to keep the differential area at a convenient working height and to leave the wheels and axles free to be rotated and removed.
- Once supported off the ground, release the parking brake and leave the vehicle in neutral. Chock the wheels if necessary.

### 2.2 Differential Fluid Drain

- Clean around the third member flange seal to prevent dirt from entering the differential.
- Position a fluid drain reservoir under the differential.
- Remove fluid drain plug to empty all differential oil.

**HINT :** This is a good time to check for metal particles in your oil which may indicate a worn bearing or differential component.

## 2 Removing the Existing Differential

### 2.3 Removing the Axles and Differential

Remove the axles according to your vehicle's service manual.

**NOTE :** Toyota OE Diff Lock must be engaged (rotate dashboard switch to lock rear diff, and rotate wheel to ensure diff is locked) before removing short axle shaft. Failure to do this will result in OE locking collar becoming jammed.

Disconnect the drive shaft from the flange of the differential.

Remove the third member from the differential housing. (Refer to your vehicle's service manual)

**NOTE :** Keep OE Diff locked to aid removal of third member. Unlock once diff has been removed.

**NOTE :** The differential housing is heavy and quite difficult to handle when covered in oil. Do not drop it!

#### **IMPORTANT :**

Collision damage or heavy off-road use of your vehicle in the past may have resulted in some degree of bending in the axle. Any misalignment of the axle tubes may result in excessive wear and/or failure of your differential and axle shafts. ARB strongly recommends that you have your axle assembly inspected for concentricity and straightness before installing your *Air Locker*.

### 2.4 Removing OE Locker Mechanism

The OE Diff Lock motor and limit switch will need to be removed to enable fitment of the *Air Locker*. They will be replaced by supplied blanking plates. (Fig. 1.)

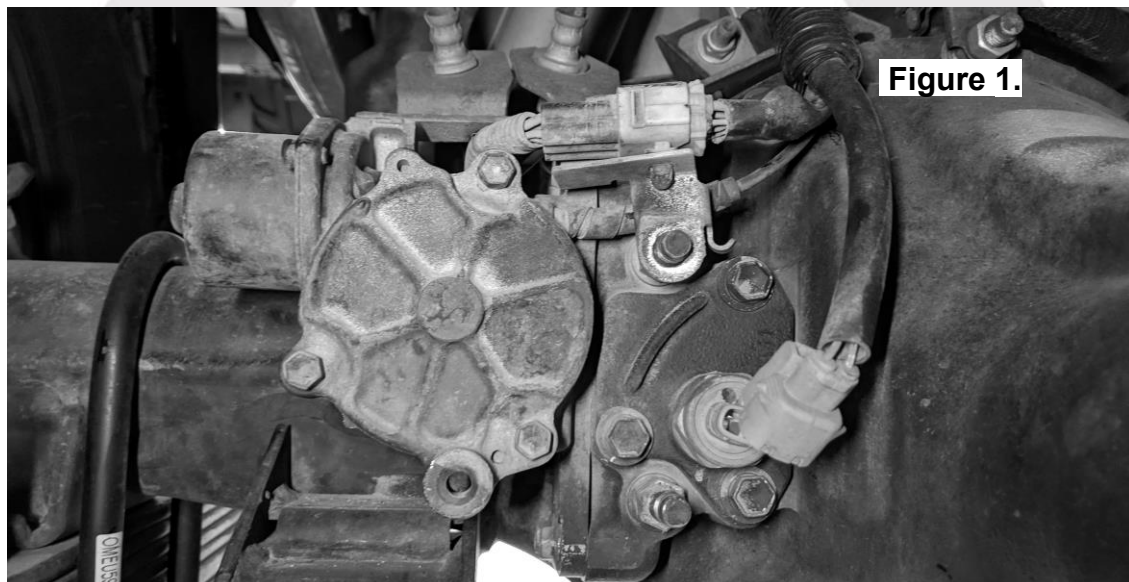
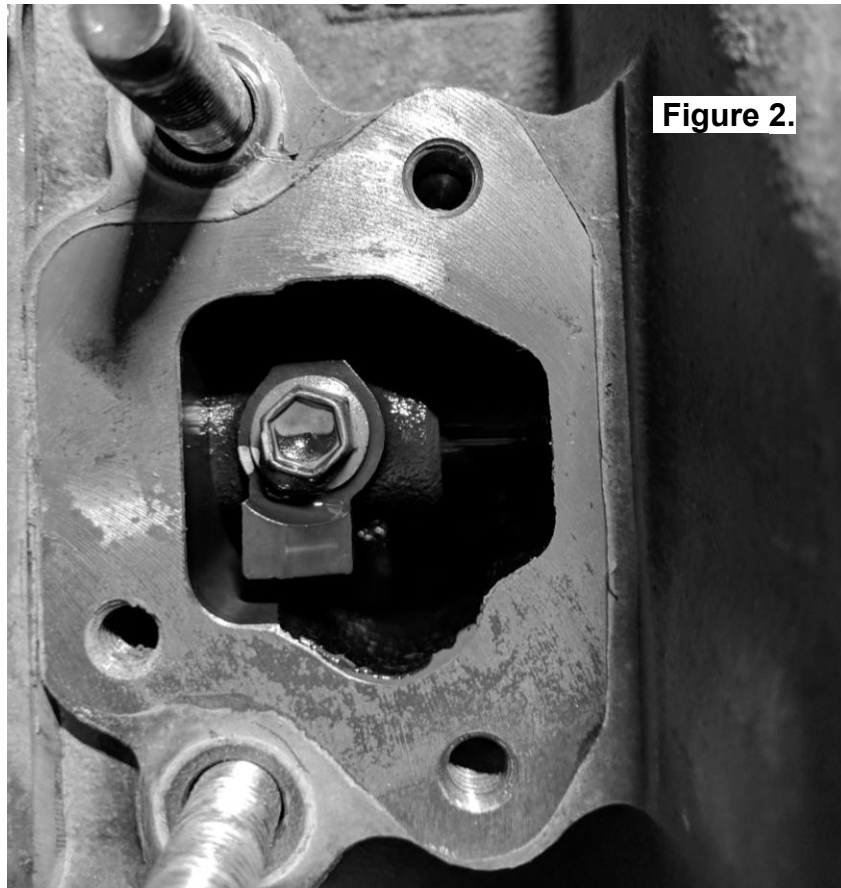

Figure 1.

## 2 Removing the Existing Differential

- Undo the 3 bolts that hold the limit switch bracket in position. Remove the bracket and switch from the diff.
- Unbolt the screw that is retaining the engagement fork to the motor shaft (Fig. 2.).



- Undo the 4 bolts holding the motor onto the housing and remove the motor. The locking gear engagement fork can be removed once it is clear of the motor shaft.

## 2 Removing the Existing Differential

### 2.5 Marking the Bearing Caps

- Using a pointed center punch, gently mark the differential housing and the bearing caps in a way that will enable you to correctly position the cap during reassembly. (Fig.3.)



### 2.6 Checking the Current Backlash Amount

#### **IMPORTANT:**

This step is a precautionary measure recommended by ARB due to the fact that some aftermarket ring and pinion sets have been manufactured to run with different backlash settings than those specified by your vehicle manufacturer. Although ARB must recommend you set backlash according to your service manual guidelines, we also advise that you compare the backlash measurements taken here to the recommended backlash settings in your vehicle service manual. Measurements found to be outside of your service manual recommendations may indicate the need to deviate from those settings in order to achieve quiet running with a good contact mark.

Refer to your vehicle service manual or your local authorized ARB installer for more information.

## 2 Removing the Existing Differential

- Set a depth indicator on one of the ring gear teeth as in Figure 4.

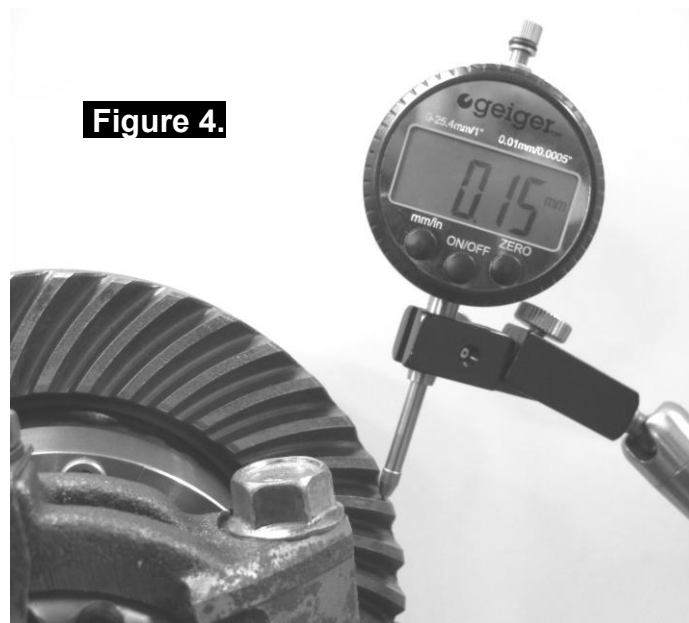

- While supporting the pinion gear by holding the drive shaft, rotate the differential in both directions while observing the maximum variation in depth from the indicator (i.e., the highest value minus the lowest value). This value is referred to as the ring and pinion backlash.
- Rotate the differential center 90° and measure again for accuracy.
- Record the average of all measurements.

## 2 Removing the Existing Differential

### 2.7 Spreading the Differential Housing

#### **IMPORTANT:**

Spreading the differential housing with a differential case spreader is a step which is critical to set up bearing pre-load when a differential is installed. Improper pre-load will result in undue bearing wear, increased stresses in the differential center, increased running noise, and ultimately, ring and pinion gear damage.

- Unbolt and remove the bearing caps.
- Setup the differential spreader and a dial indicator and carefully spread the differential housing (Fig.5.) just enough to remove the differential carrier (Refer to your vehicle's service manual).

**NOTE :** Never spread the housing more than 0.5mm [0.020"].

- Once the housing has been adequately spread, the differential may be removed by pulling forward on the differential center.
- Remove spreader tension.

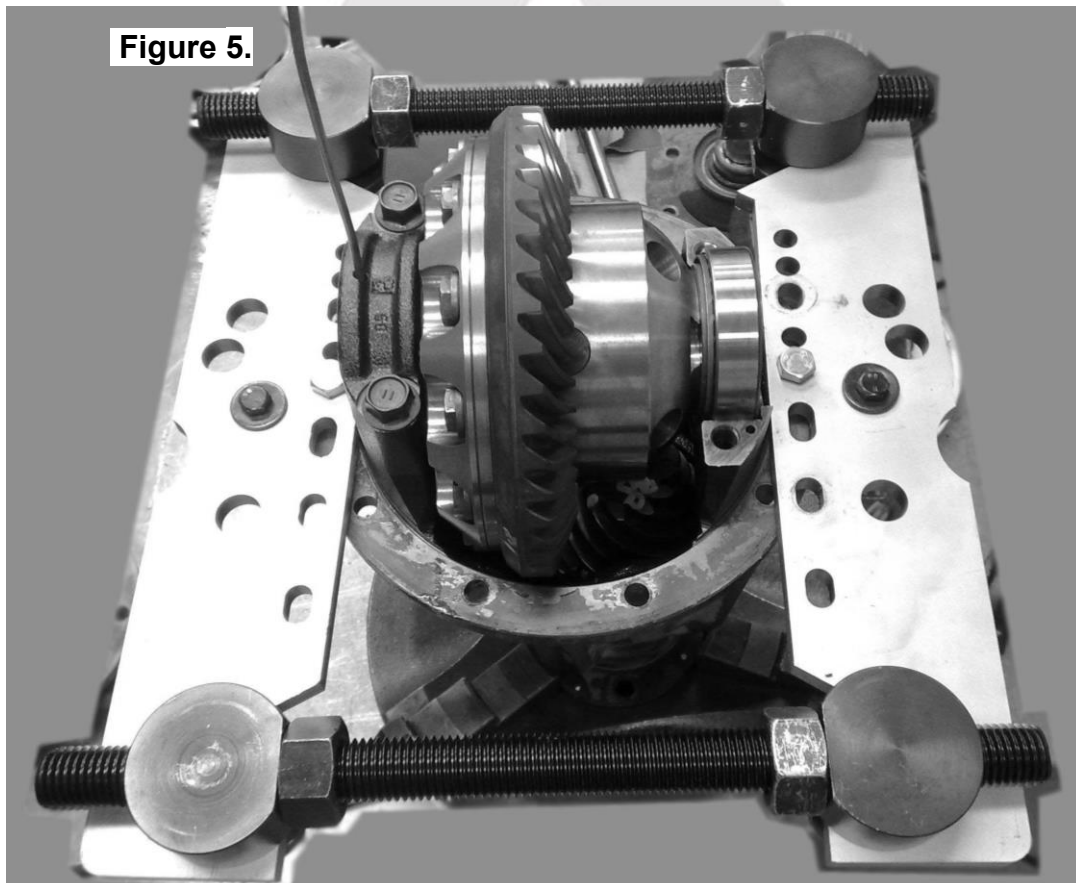

## 3 Bench Measurement

### 3.1 Approximate Backlash Shimming

In order to reproduce a similar pre-load and ring and pinion backlash in your *Air Locker* to that of your original differential, measurements need to be taken so that a shim thickness can be calculated.

- Secure the original differential to a work bench.
- Remove the bolts that hold the ring gear in place.
- Using a plastic or copper hammer, tap in a circle around the ring gear to separate it from the differential carrier.
- Remove the original bearings and shims from the differential center using a bearing puller.

**NOTE :** Keep the bearings and shims separated so that they can be identified as to which end of the differential they came from.

- Examine the bearing cups and cones from Figure 6. for damage or wear and, if necessary, discard them and replace with the same size and type of bearings.

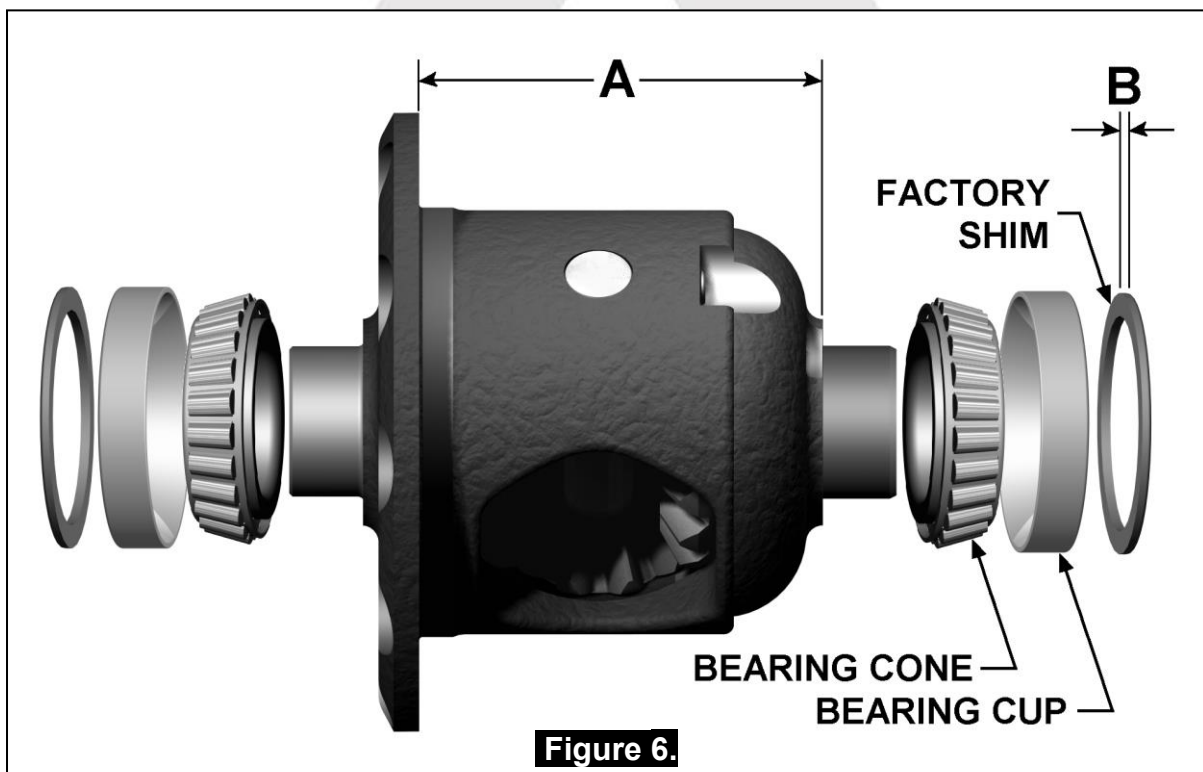

### 3 Bench Measurement

- Using a caliper or similarly accurate measurement method (i.e., able to take accurate measurements within 0.04mm [0.0015"]), measure the distance from the shoulder of the bearing journal to the ring gear mounting face (shown as 'A' in Fig.6.) and record this measurement as 'A'.
- Measure the thickness of the factory shim removed from the end of the differential carrier (shown as 'B' in Fig.6.) and record this measurement as 'B'.

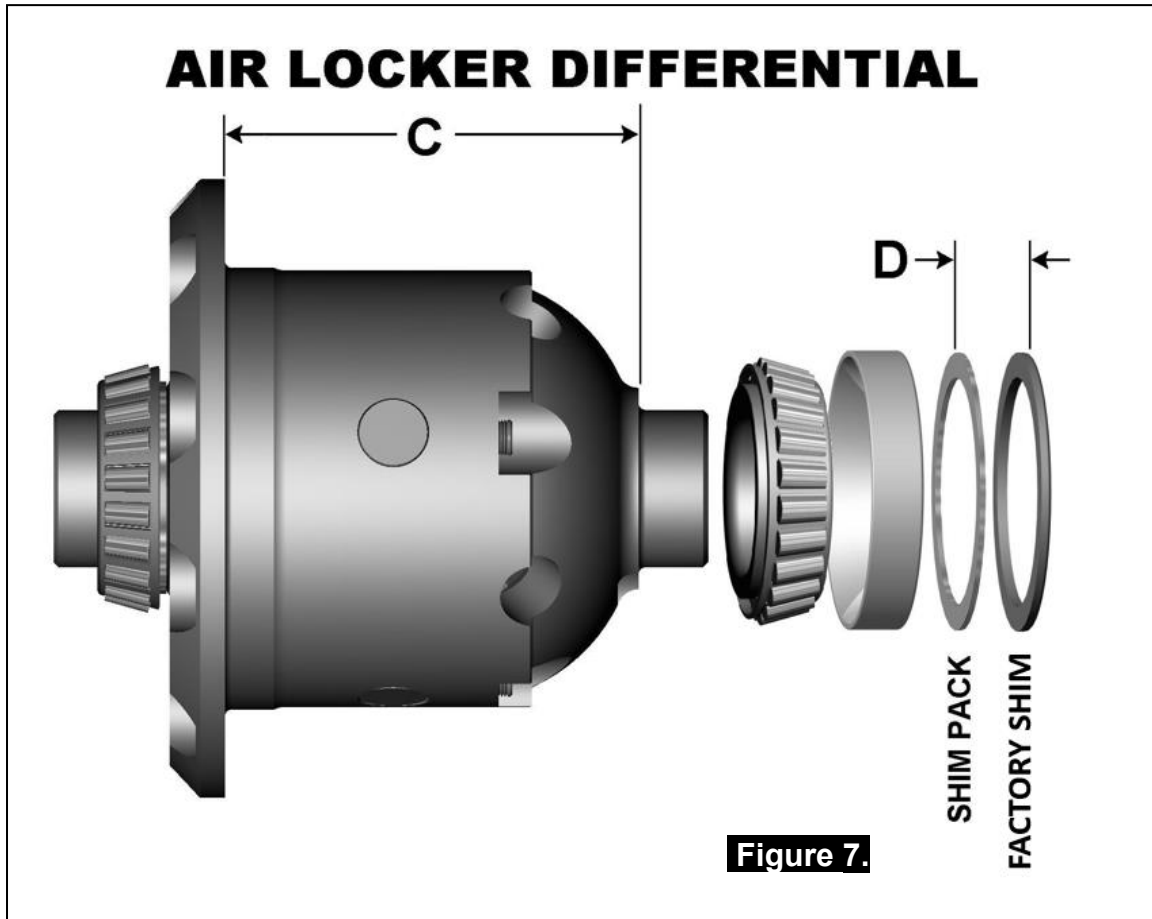

- Measure the distance from the *Air Locker* bearing shoulder to the ring gear mounting face (shown as 'C' in Fig.7.) and record this measurement as 'C'.

### 3 Bench Measurement

#### 3.2 Calculation & Selection of Shims

Ideally, the measurement you recorded as 'C' from the *Air Locker* differential will closely match 'A' on the existing differential (within 0.1mm [0.004"]) and then the factory shim can be reused, however, quite often these measurements will vary slightly between one factory differential and the next.

If this is the case you must create a new shim pack thickness by using the measurements you recorded earlier to find a desired measurement for 'D' in Figure 7.

Use the following calculation:

$$A + B - C = D \text{ (Replacement Shim Pack)}$$

**HINT :** If your calculations are correct then the following equation will also be true:

$$A + B - C - D = \text{ZERO}$$

Create a shim pack to match the thickness calculated as 'D'.

To achieve the desired shim thickness you can:

- Machine down the factory shim thickness.
- Add shims between the factory shim and the bearing cup.

**HINT :** A selection of shims of this size have been supplied with your *Air Locker* kit.

- Purchase new factory shims at the desired thickness.
- Use a universal shim kit available from most drive train specialists.

**NOTE :** NEVER machine the *Air Locker*.

## 4 Installing the Air Locker

### 4.1 Installing the Carrier Bearings

- With the *Air Locker* well supported in an arbor press, apply a thin film of high pressure grease to both bearing journals.
- Press one of the tapered roller bearing cones onto the ring gear side bearing journal first until the bearing seats firmly against the bearing journal shoulder.
- Invert the *Air Locker* and press the second bearing cone onto the diff case side bearing journal until the bearing seats firmly against the bearing journal shoulder (Fig. 8.).

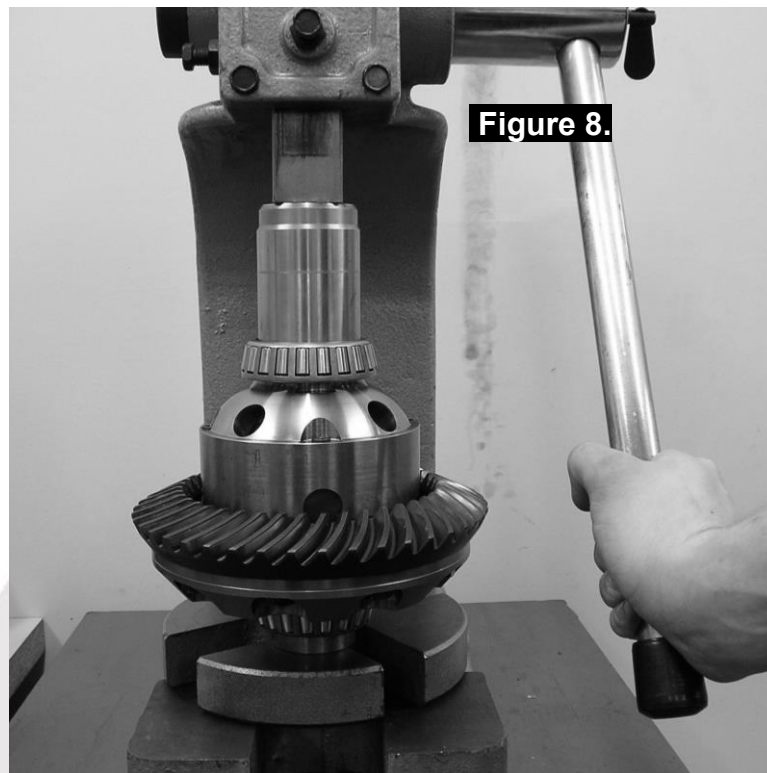

**NOTE :** Never re-use any bearings which are damaged or worn.

## 4 Installing the Air Locker

### 4.2 Mounting the Ring Gear

- Apply a thin film of high-pressure grease to the ring gear shoulder of the *Air Locker* to prevent seizing.
- Thoroughly clean any thread locking compound or other foreign matter from the holes of the ring gear, the threads of the ring gear bolts, and the mating surfaces of the ring gear and the *Air Locker* flange.

**NOTE :** Rubbing the ring gear mounting face with a flat oil stone before installation will remove any high spots around the threads.

- Heat the ring gear to between 80 and 100°C (175 - 212°F) in an oven or in hot water to slightly expand the gear and facilitate assembly.

**NOTE :** NEVER HEAT GEARS WITH A FLAME! This could damage the hardened surface of the gear and result in premature wear or failure.

- Dry the ring gear with compressed air (if wet), paying particular attention to the threaded holes.
- Install the ring gear onto the *Air Locker* by aligning the holes in the flange with the tapped holes in the ring gear, then gently tapping it around in a circle with a plastic or copper hammer.

**NOTE :** Avoid using the bolts to pull down the ring gear as this puts excess strain on the bolts and the differential flange.

- Apply a thread locking compound (e.g. Loctite 272) to the thread of each ring gear bolt before inserting it.

**NOTE :** Do not apply threading compound directly into the threaded hole as this could prevent the bolt from reaching its full depth.

- Tighten the ring gear bolts in a star pattern with a torque wrench according to your vehicle manufacturer's specified torque.

## 4 Installing the Air Locker

### 4.3 Assembling the Seal Housing

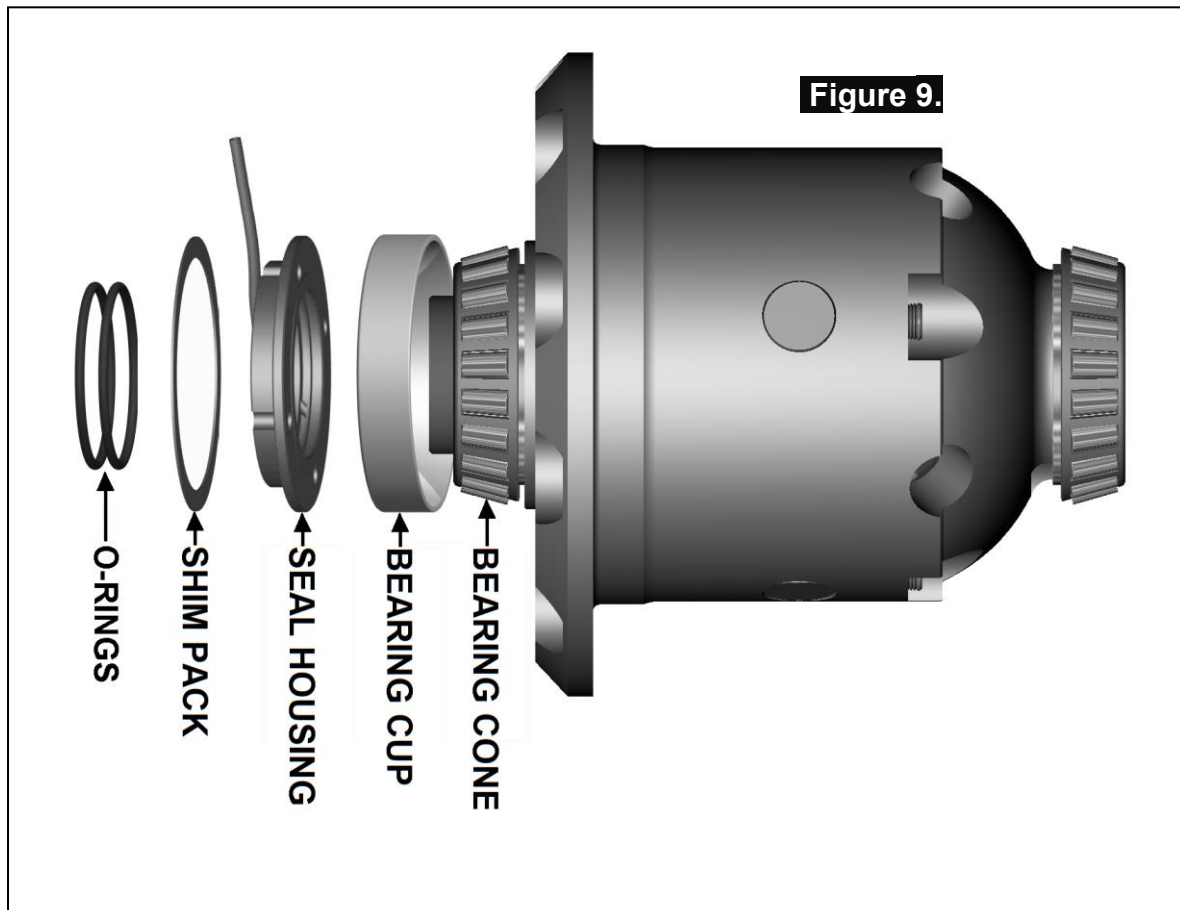

- Make sure the grooves and airway of the seal housing are clean and free from any contaminants (e.g. water, dirt, metal filings, etc.).
- Inspect the seal housing O-rings (supplied) for dirt, damage or other conditions which might cause leaks.
- Generously lubricate the O-rings with oil prior to assembly, then insert them into the grooves of the seal housing.

**NOTE :** When assembling the O-rings, be careful not to leave them twisted when seated in the grooves as this could cause excessive wear and leakage.

- Lubricate the seal housing running surface on the *Air Locker* carrier with oil. Assemble the bearing cup onto the left-hand side of the *Air Locker*.
- Carefully install the seal housing by sliding it all of the way onto the bearing journal with a gentle twisting motion (Fig. 9.). This will allow the O-rings to engage gently.

## 4 Installing the Air Locker

### 4.4 Calculation & Selection of Pre-Load Shims

In order to pre-load the tapered roller bearings in your *Air Locker*, measurements need to be taken so that a value can be calculated for the shim thickness 'E' in Figure 10.

- Hold the bearing cup and shim pack 'D' (Fig.5.) in place, and insert the *Air Locker* into the housing.
- Push the *Air Locker* hard across against the bearing and shim pack 'D', and measure the gap between the end of the seal housing assembly and the bearing seat of the differential housing with a feeler gauge.
- Consult your vehicle manufacturer's service manual to determine the carrier bearing pre-load amount specified for your vehicle.
- Add the specified pre-load amount to the measurement taken with the feeler gauge to determine a shim amount for 'E' in Figure 10.

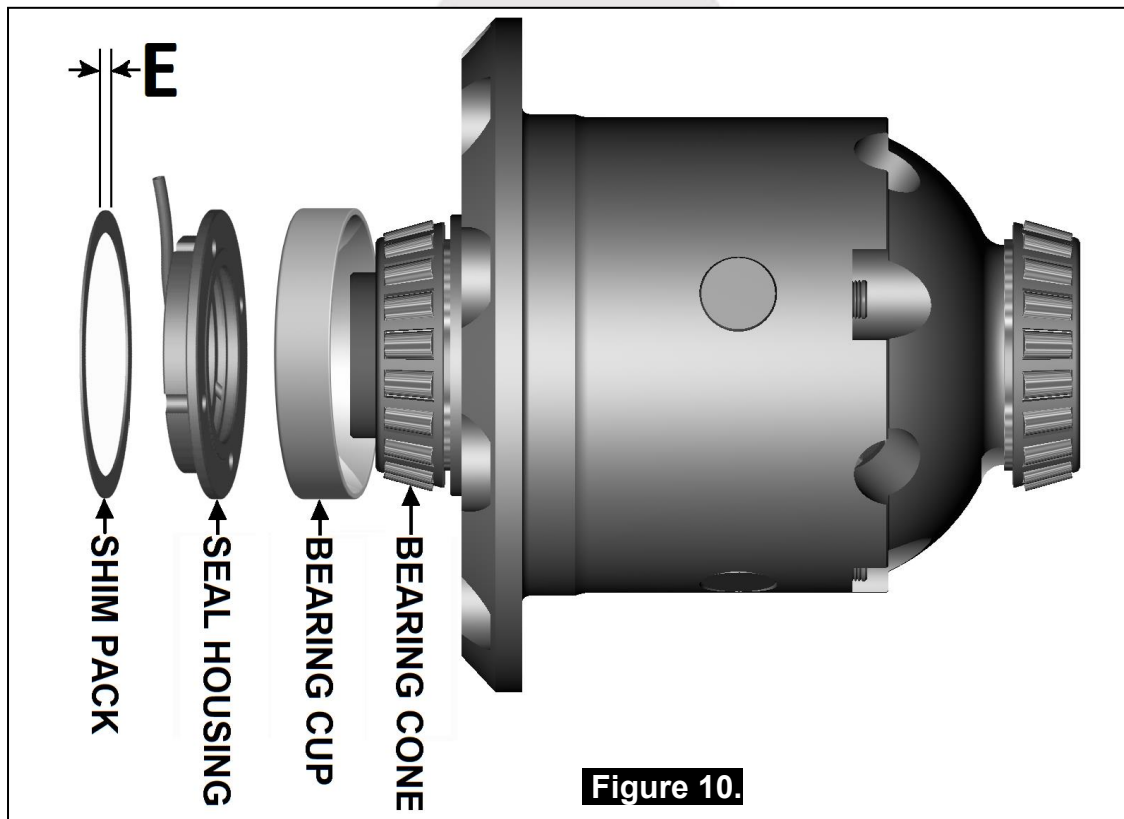

Figure 10.

**PRE-LOAD + END FLOAT = SHIM PACK**

- Select suitable shims from the shim kit supplied with your *Air Locker* to make up a shim pack of this thickness. (Refer to section 3.2 for methods of shim adjustment).

## 4 Installing the Air Locker

### 4.5 Final Air Locker Assembly

- Spread the differential housing again (Refer to section 2.6).
- Hold shim pack 'E' (Refer to section 4.4) in position on the *Air Locker*.
- Reinstall the *Air Locker* into the differential housing.
- Place the seal housing bearing cap in place to align the seal housing.
- Using a Shim Driver, lightly tap shim pack 'D' into place on the right-hand side between the bearing cup and the bearing seat of the axle assembly.

**NOTE :** If the carrier is too difficult to install with the added shim pack then the spreader tension may need to be increased. **Do not spread the housing more than 0.50mm [0.020"]**.

- Relieve all tension on the housing spreader.
- Place the remaining bearing cap in place, and tighten all bearing cap bolts with a torque wrench to the torque specified in your vehicle manufacturer's service manual.

### 4.6 Final Backlash Checking

- Set a depth indicator on one of the ring gear teeth as in Figure 11. While supporting the pinion gear by holding the drive flange, rotate the differential in both directions while observing the maximum variation in depth from the indicator (i.e., the highest value minus the lowest value). This value is referred to as the ring and pinion backlash.
- Rotate the differential center 90° and measure again for accuracy.

Figure 11.

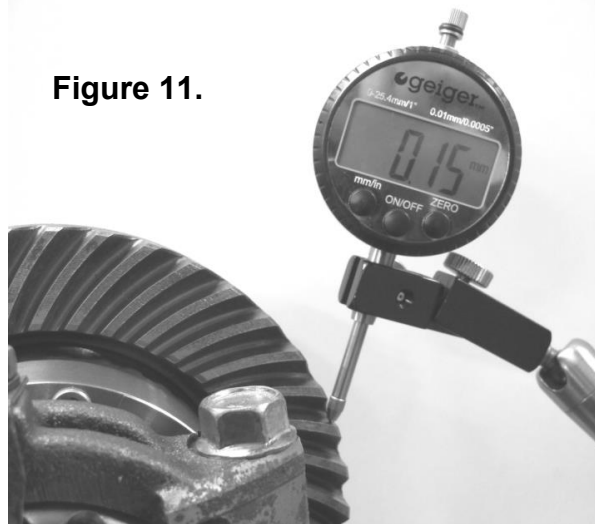

## 4 Installing the Air Locker

- Refer to your vehicle service manual for the specified maximum and minimum amounts of backlash. If the backlash is not within the specifications then the differential will have to be removed and re-shimmed.

### 4.6.1 Re-Shimming the Backlash

---

**NOTE :** This step is only necessary when adjusting for incorrect backlash.

- Reapply the spreader to the differential housing.
- Remove the bearing caps.
- Remove the differential.
- To increase the amount of backlash, reduce the shim thickness 'D' (Fig.7.) and increase the shim thickness 'E' (Fig.10.) by the same amount. Reverse this step to decrease the backlash.
- Remount the differential as before.
- Release spreader tension.
- Check backlash again as before.

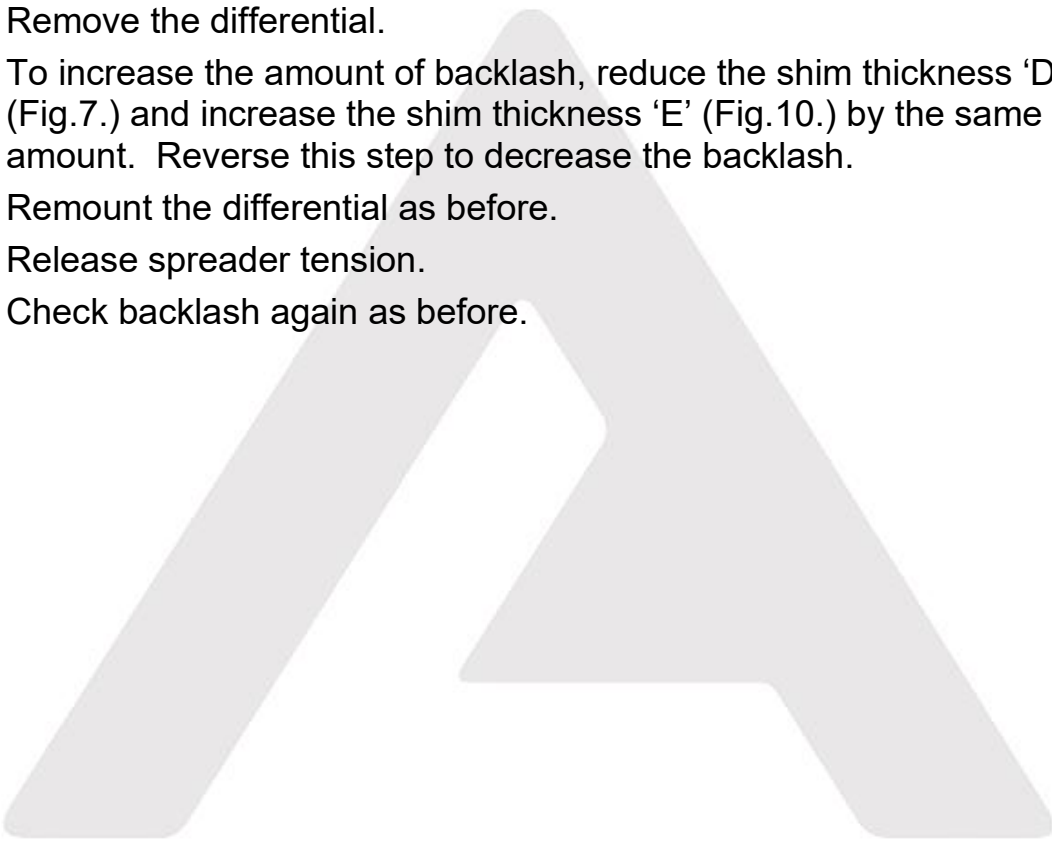

## 4 Installing the Air Locker

### 4.7 Profiling the Seal Housing Tube

The seal housing tube will need to be profiled so that it is clear of both the *Air Locker* as well as the axle housing.

- Without using sharp, jagged tools such as pliers (usually your hands are the best tool for this job), bend the seal housing tube so that it closely follows the profile of the differential. Refer to Fig.12., Fig.13., Fig.14., and Fig. 15. for recommended profile.
- Trim the tube to length using the automotive brake line cutters.



## 4 Installing the Air Locker

Figure 13.



Figure 14.



## 4 Installing the Air Locker

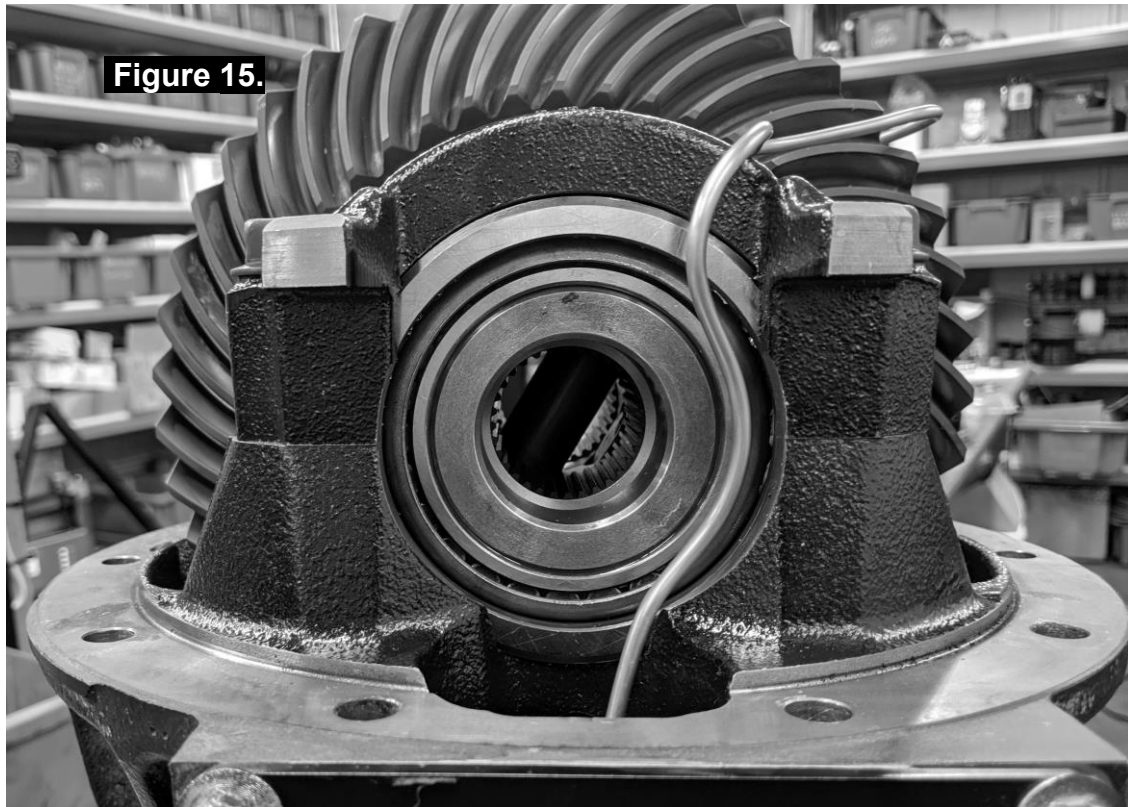

- Check that the contour of the tube will not interfere with the *Air Locker* or the ring gear.
- Direct the tube to exit through the opening left by the removal of the OE locker limit switch.

**NOTE :** It is a good idea to keep the tube away from the bearing caps or any other part of the differential casting as any contact due to vibration or shock may wear the tube and eventually cause a leak.

## 4 Installing the Air Locker

### 4.8 Setting up the Bulkhead Fitting

Two blanking plates (supplied) will need to be bolted to the differential housing to block up the holes left by the removal of the OE Diff Lock motor. One plate is used for the bulkhead fitting, the other is used to support the brake line mounting bracket (Fig. 16.).

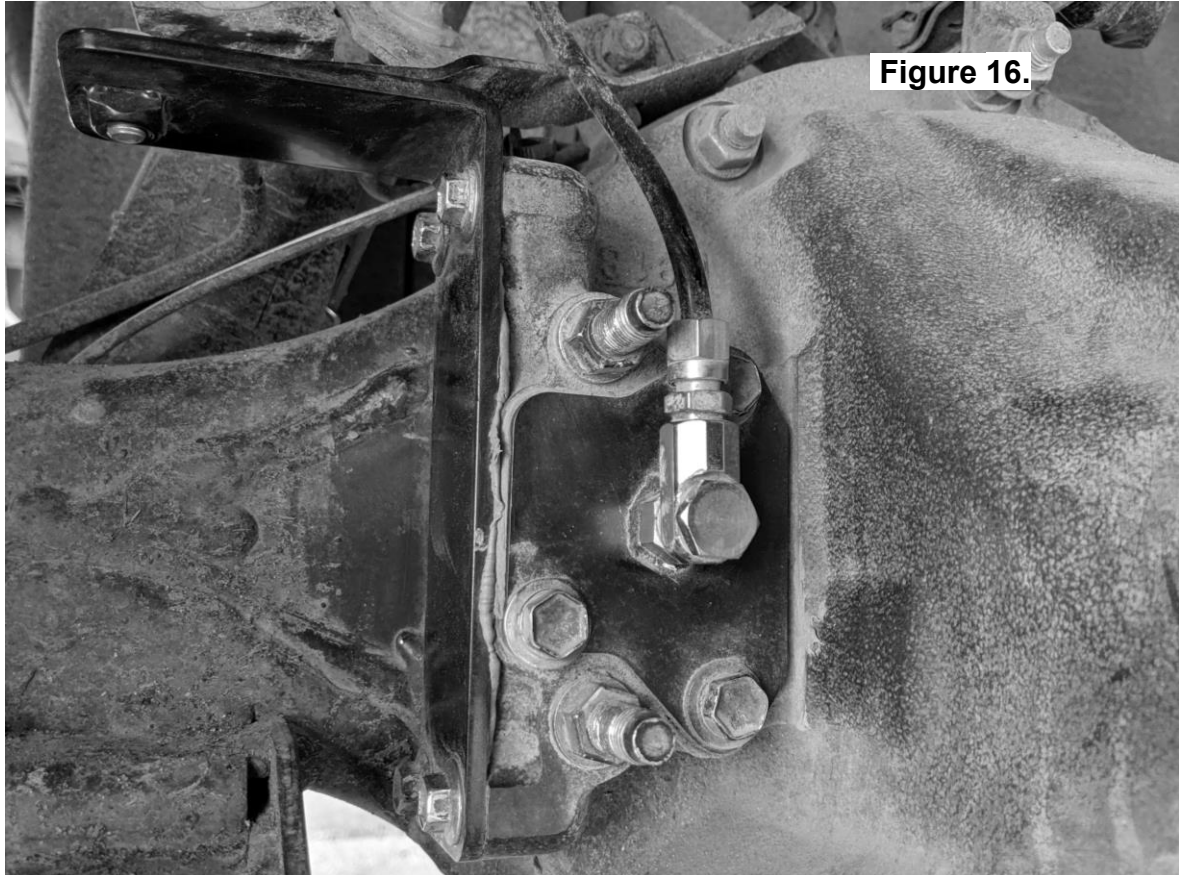

- Apply gasket sealant to both of the blanking plates, and attach to differential housing re-using the factory Toyota bolts.
- Apply thread sealant to the outside threads of the bulkhead body.
- Screw the bulkhead body into the tapped hole, and lightly tighten using a 14mm [9/16"] spanner.
- Wipe the area clean of any excess thread sealant (inside and outside of the housing).
- Insert the free end of the seal housing tube into the bulkhead fitting until it protrudes approximately 8mm [5/16"] through the other side.
- From the outside of the housing, assemble one of the small O-rings over the top of the short length of seal housing tube protruding through the bulkhead fitting.
- Install the brass spacer.
- Install the second small O-ring after the spacer.

## 4 Installing the Air Locker

- While holding the seal housing tube into the bulkhead fitting, insert the chamfered end of the center compression nut over the extended tube as shown in the assembly diagram (Fig. 17.), and screw it into the bulkhead body, and tighten using Pozidriv #3 screwdriver.

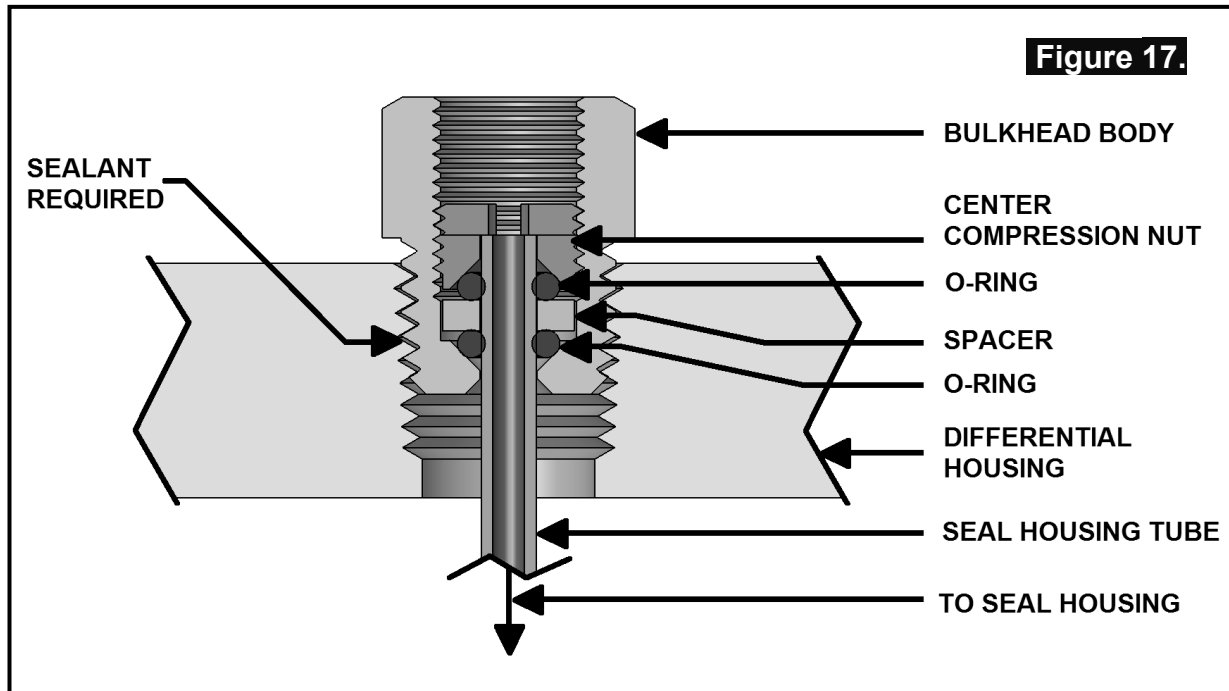

**NOTE :** Make sure the seal housing tube is all of the way into the center compression nut while you are tightening it.

**NOTE :** Firmly tighten the center compression nut so that a good seal is formed around the tube.

- Again check that no part of the seal housing tube comes in contact with the moving differential components. Gently bend the tube away from moving parts if necessary.

### 4.9 Bench Testing the Air Locker

- To test the *Air Locker*; when 620kPa [90 PSI] shop air is applied to the seal housing tube, the *Air Locker* should engage.
- Check all fittings and the seal housing for air leaks.
- Rotate the differential carrier by turning the pinion flange whilst applying air pressure.

## 4 Installing the Air Locker

**NOTE :** An accurate way to test for air leaks is to fit a shut-off valve to an air pressure gauge (ARB part # 0770005). Once 620 KPA [90 PSI] is reached close the valve, disconnect the air hose, and watch to see if there is any drop in pressure. If so, this will indicate an air leak. (Fig.18.)



- If a leak is found to be present, spray a soap and water mixture onto the bulkhead air fitting. Bubbles should appear at any leak points.

**NOTE :** Do not spray this soapy mixture inside the differential.

- Check that leaky fittings have been adequately tightened.
- Disassemble, clean threads, and reapply thread sealant if leaking persists.
- If a leak is found at the seal housing, carefully remove the seal housing assembly and examine the O-rings. Be very careful with the O-rings and check for defects, damage, wear, or presence of foreign material in the O-ring grooves. Replace if necessary.

### 4.10 Reinstalling the Differential and Axles

- Reinstall the third member to the differential housing according to your vehicle service manual. Ensure that the copper tube does not contact the inside of the axle housing, or touch on the ring gear.
- Reinstall the drive shaft.
- Replace the axle seals if necessary and fit to the axles.
- Insert both axles fully into the housing, engaging splines, and then gently tap them inward.

**NOTE :** Be careful not to damage the axle shaft oil seals when installing the axle. Support the axle's entire weight where possible.

- Torque down the axle bolts to manufactures specifications.

## 5 Installing the Air System

### 5.1 Mounting the Solenoid

#### 5.1.1 Connection to an ARB Air Compressor (Fig.19.)

- Remove one of the 1/8" BSP plugs from its port in the compressor tank.
- Apply Teflon paste to the 1/8" BSP nipple on the solenoid and insert it into the port and tighten. The solenoid should be rotated into a position which does not obstruct any other ports on the compressor tank.

**NOTE :** The coil and stem of the solenoid can be removed to make installation easier.

**NOTE :** The solenoid is marked with two #1 ports. If space is tight, a second solenoid can be "daisy-chained" off the first one by removing the plug from the redundant #1 port and screwing the nipple from the second solenoid into it (Fig. 19.).

**NOTE :** The solenoid exhausts compressed air through the center of the black retaining cap when the *Air Locker* is disengaged. Make sure this orifice cannot be obstructed.

- Assemble the 6mm push-in fitting into the solenoid outlet port (stamped "2") and hand tighten.

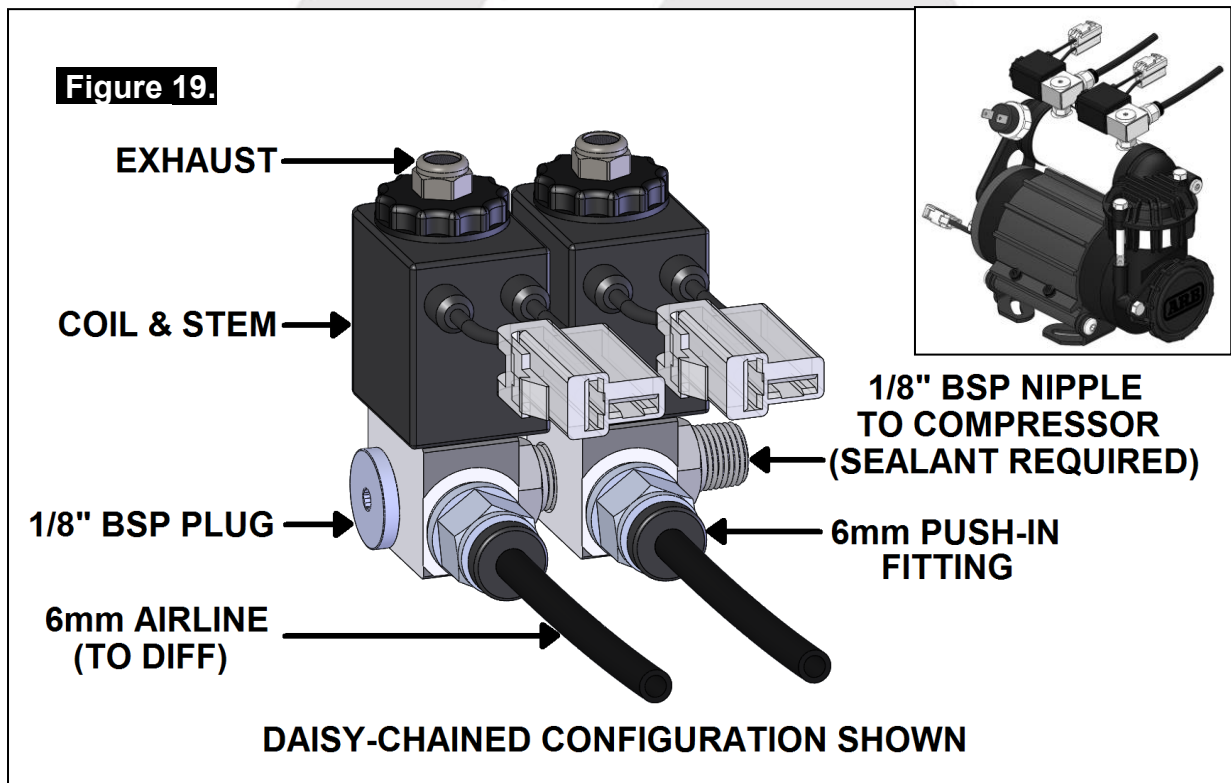

## 5 Installing the Air System

### 5.1.2 Connection to an Alternate Air Source

---

For ease of installation, quality of air supply, and a high level of dependability from your *Air Locker(s)*, ARB strongly recommends use of a genuine ARB Air Compressor, however, the *Air Locker* air system can be operated on any alternate air source that meets each of the following guidelines:

- Must supply a minimum of 85PSI [586kPa].
- The Air source should have a tank capacity that enables it to actuate the *Air Locker(s)* in one charge so that no hesitation is experienced when locking one or two differentials.

**HINT :**     **A good way to insure that you have the necessary capacity is to make sure you can engage, disengage, and then reengage your *Air Locker(s)* without the air source having to regenerate (e.g., without the compressor turning on to refill the tank).**

- Must supply clean air, free of rust, dirt, water, or other foreign matter.
- Must match the 1/8" BSP porting of the *Air Locker* solenoid.
- Mount solenoid within close proximity of the air supply and secure it from the effects of vibration and shock.
- Connect the air supply to the 1/8" BSP inlet port of the solenoid (stamped "1" on the solenoid body) using thread sealant.

#### **IMPORTANT :**

**ARB cannot warrant your *Air Locker(s)* against damage caused as a result of using an alternate air supply. If you have any doubts as to the suitability of your air system to use in an *Air Locker* system, consult your ARB distributor.**

## 5 Installing the Air System

### 5.2 Running and Securing the Air Line

The path taken by the air line from your air source (i.e., compressor) to your *Air Locker* is unique to your vehicle and the position of your air source. Plan ahead carefully when running the air line and always follow these guidelines:

- Account for axle travel when running the line from the axle to a fixed point on the vehicle. Leave enough slack in the air line to allow for maximum suspension travel in both directions.
- Avoid leaving large lengths of air line hanging underneath the vehicle where they may get tangled on rocks, sticks, etc.

**HINT :** **Cable tying the air line to one of your flexible brake lines will account for axle travel and should help keep your line from getting snagged.**

- Run the air line all the way from the compressor to the differential before trimming either end of the line to length. This will save complications that may arise if the air line has to be removed.
- Make sure the line does not contact sharp edges or abrasive surfaces that may damage the air line over time.
- Do not run the air line around tight bends which may kink the air line and restrict or block the air flow.
- Keep the air line well away from your vehicle's exhaust components. Air lines will melt if subjected to extreme heat.
- Do not run more air line than necessary. Excess line volume created when coiling the left over hose, using unusually large diameter hose, etc., will increase drain on the compressor tank resulting in the compressor running more often than needed.
- Support the air line by tying it back with cable ties wherever possible.
- At the solenoid end of the air line, trim the line to length with a sharp knife.

**NOTE :** **To remove the air line from the push-in fitting; while holding the flange of the fitting out, push the air line into the fitting as far as possible, then press the flange inward, then pull the air line free of the fitting.**

- To attach the air line to the push-in fitting of the solenoid; insert the line firmly into the fitting, pull outward on the flange of the fitting while holding the line as far into the fitting as possible, and then gently pull outward on the air line to clamp the line in place.

## 5 Installing the Air System

### 5.3 Connection to the Bulkhead Fitting

- Trim the air line to length using a sharp knife.
- Assemble an aluminium washer onto the banjo bolt and insert through the banjo fitting. Assemble second aluminium washer and tighten into bulkhead fitting using a 14mm [9/16"] spanner. (Fig.19.)
- Apply thread sealant to the tapered thread of the compression fitting body and screw into the banjo fitting. Tighten using a 12mm spanner.
- Insert the outer compression nut and ferrule over the air line. Ferrule should be orientated as per Fig.19.

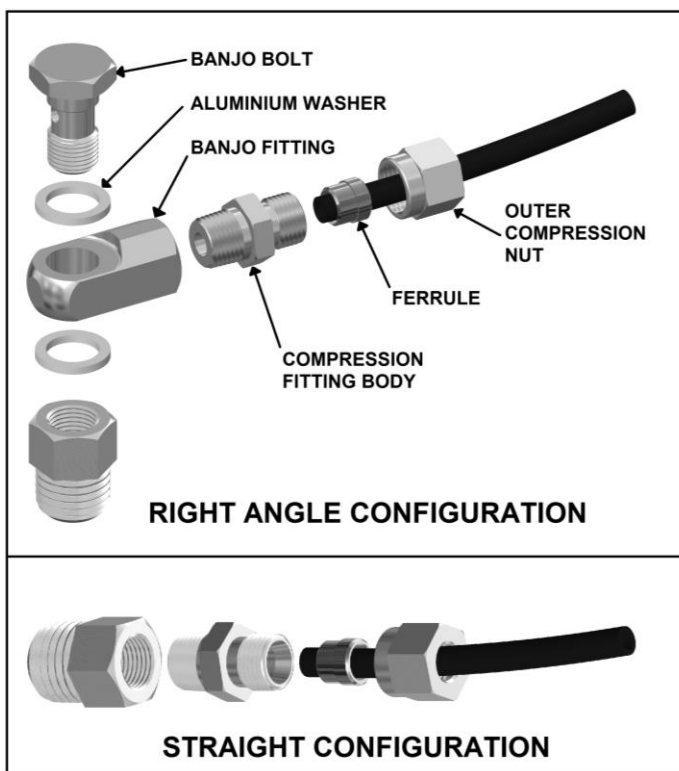

- Push the airline into the compression fitting body and screw the outer nut down onto it. Using a 12mm spanner, tighten the outer nut onto the compression fitting body.

**NOTE :** Some force is required to crush the ferrule, however the outer compression nut will tighten against a stop. Over tightening will not create a better seal.

- Secure any loose sections of tube with a cable tie.

**NOTE :** When right angle routing of the tube is not required, screw the compression fitting body straight into the bulkhead fitting body (Fig.20.).

## 6 Mounting & Connecting the Electrical System

### 6.1 Rear Differential Lock Sensor Replacement

The Toyota Rear Diff Lock contains a sensor that provides a signal to the Toyota 4WD Control Computer when the Diff Lock is engaged. This signal is required before the Toyota 4WD Control Computer will allow the Front Diff to be locked. Since this sensor has been removed during the *Air Locker* installation, the sensor signal needs to be replicated with a relay as shown in Figure 21.

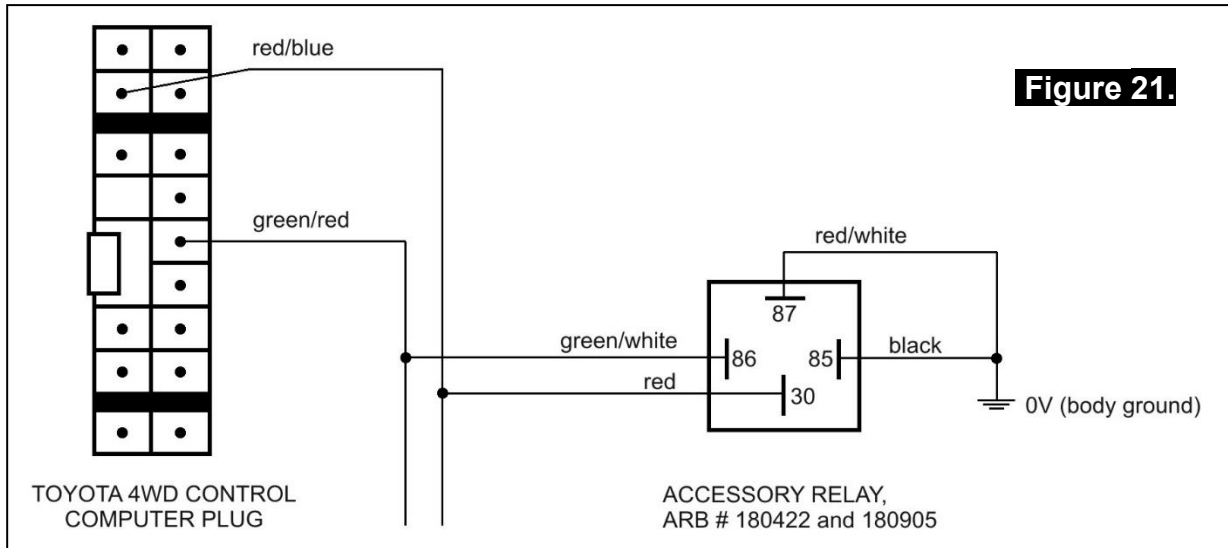

**NOTE :** The Toyota 4WD Control Computer is located on the right side of the vehicle in the footwell area, as shown in Figure 22.

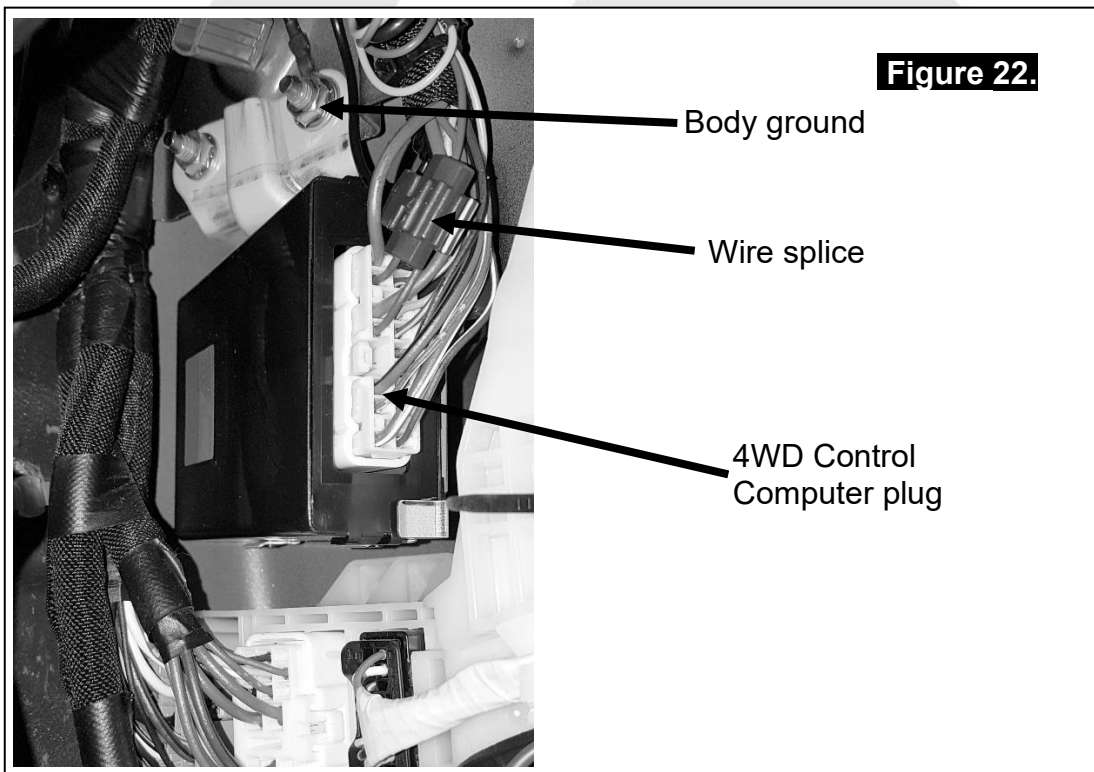

## 6 Mounting & Connecting the Electrical System

### 6.2 Wiring Modifications

#### 6.2.1 Standard Install using Toyota Diff Lock Switch

The Toyota Diff Lock switch should be used instead of the ARB switch as it is not only suitable to switch the ARB *Air Locker* solenoid, but crucially it also provides a signal to the Toyota 4WD Control Computer which then in turn allows the Front Toyota Diff Lock to be activated.

- Install the ARB Compressor wiring harness as per instruction, with the exception of the *Air Locker* switches.
- Access the connector plug on the back of the Toyota Diff Lock switch. To do this, remove the lower dash trim panel (below the steering column) as shown in Figure 23.



## 6 Mounting & Connecting the Electrical System

- Unplug the connector and locate the Green/Red striped wire as shown in Figure 24. This wire receives 12V when the Toyota switch is turned to Rear Diff Lock.

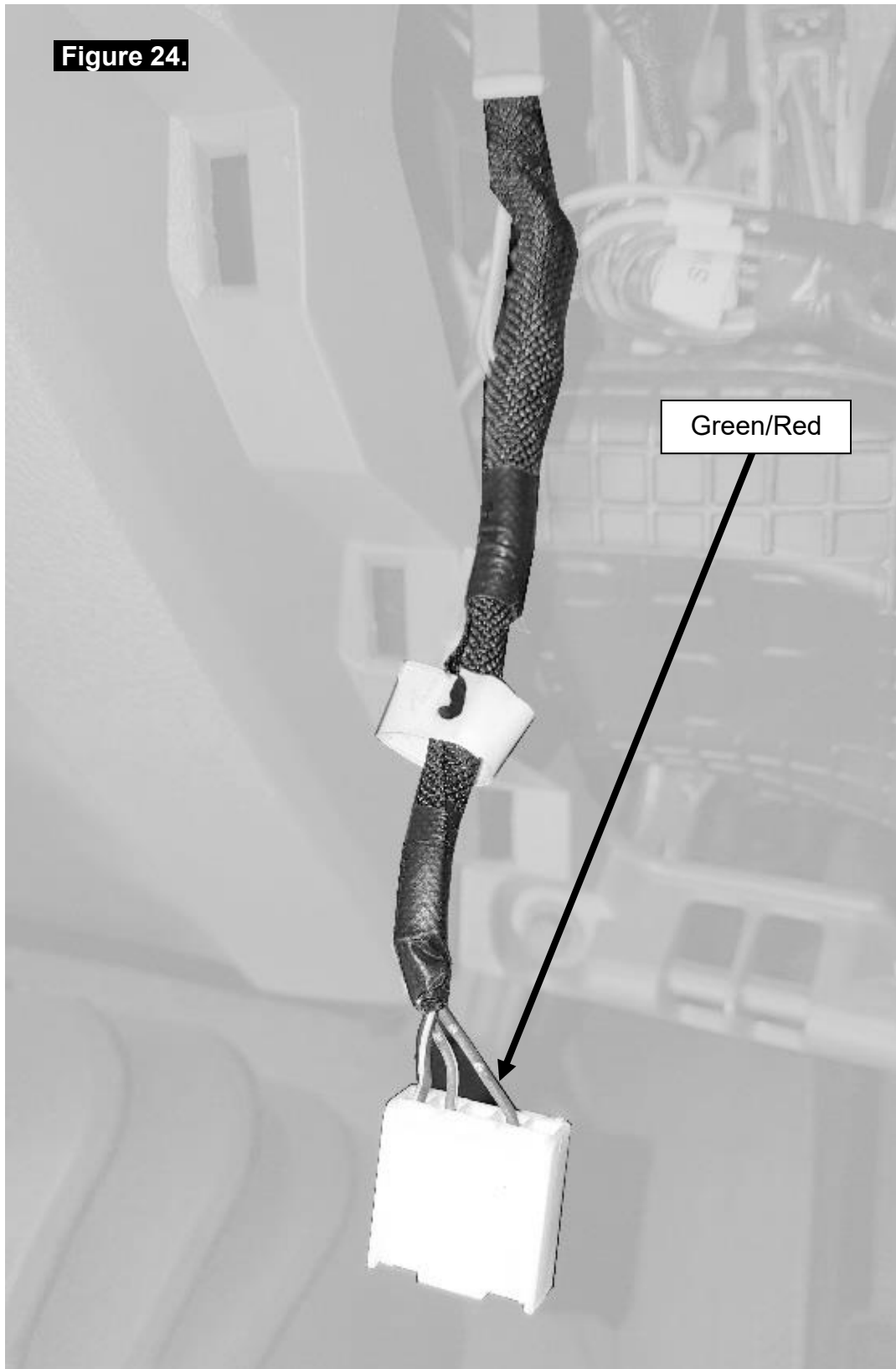

## 6 Mounting & Connecting the Electrical System

- Expose the Green/Red striped wire back from the plug in the loose section of the Toyota Harness.
- Cut the quick connect terminal off the end of the Yellow *Air Locker* switch wire.
- Splice the two wires together using a suitable method, then secure the Yellow wire to the Toyota wiring harness with a cable tie or tape (Figure 25.).

**Figure 25.**



## 6 Mounting & Connecting the Electrical System

### 6.2.2 LINX Install using Toyota Diff Lock Switch

This installation will allow both the Rear ARB *Air Locker* and the Front Toyota Diff Lock to be controlled by both the ARB LINX and the Toyota Diff Lock switch.

Before attempting this installation both of the following need to be completed first:

- The ARB Compressor wiring harness should be installed as per the instructions with the exception of the *Air Locker* switches (front and rear).
- The ARB LINX including the wiring harness, LINX Patch – Air Locker/Compressor (#180420) should be installed as per instructions.

The Toyota Diff Lock switch should be used instead of the ARB switch as it is not only suitable to switch the ARB *Air Locker* solenoid, but crucially it also provides a signal to the Toyota 4WD Control Computer which then in turn allows the front Toyota factory diff lock to be activated

- Access the connector plug on the back of the Toyota diff lock switch. To do this, remove the lower dash trim panel (below the steering column) as shown in Figure 23.
- Unplug the connector to give some slack in the wiring harness. Locate the Green/Red and Green/White striped wires as per Figure 26. When the Toyota switch is turned to Rear Diff Lock it supplies 12V to the Green/Red wire. When turned to Front Diff Lock it supplies 12V to the Green/White wire.

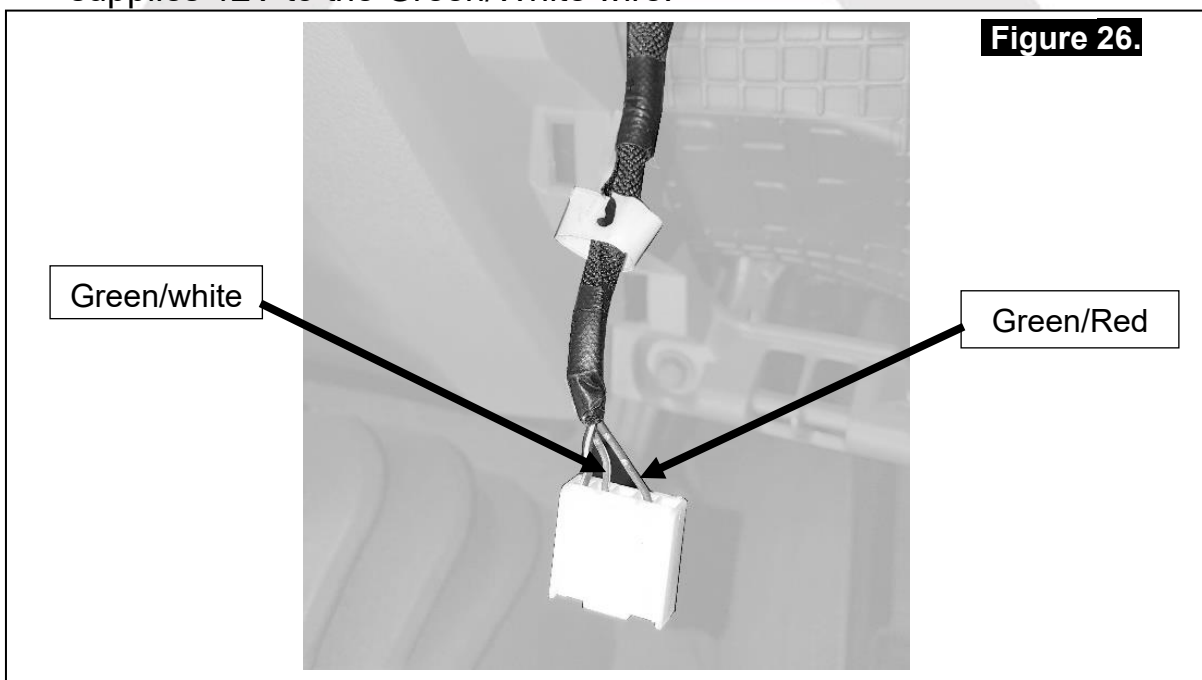



## 6 Mounting & Connecting the Electrical System

- Expose the Green/Red and Green/White striped wires a few centimeters back from the switch plug in the loose section of the Toyota harness.
- Cut the Green/Red wire. Also cut the quick connect terminal off the end of the Yellow *Air Locker* switch wire.
- Join the Green/Red wire on the switch side and the Yellow wire using a suitable method.
- Cut the Green/White wire. Also cut the quick connect terminal off the Green *Air Locker* switch wire.
- Join the Green/White wire on the switch side and the Green wire using a suitable method.

Now the LINX outputs need to be connected to the other side of the cut Green/Red and Green/White wires that go to the Toyota 4WD Control Computer. This will allow for the Front Toyota Diff Lock to be controlled, and the correct Front and Rear Diff Lock symbols to be displayed on the dashboard.

- Join the Green/Red wire to the Yellow/White wire on the LINX patch wiring harness. The firewall plug end of this harness is the most convenient place.
- Also join the Green/White wire to the Green/White wire on the LINX patch wiring harness. Once again, the firewall plug end of this harness is the most convenient place.

## 7 Testing & Final Assembly

### 7.1 Leak Testing

- With the vehicle parked and the engine off, turn the compressor on and wait until the air system is fully charged.

**NOTE :** With the *Air Locker(s)* disengaged, the air source (i.e., compressor) should not have to recharge over time. Intermittent recharging without *Air Locker* use usually indicates a leak at the solenoid fittings or at the compressor tank O-ring seal.

- Actuate the *Air Locker(s)*.
- The compressor should not come on again for a period of at least 15min. Air system recharging within that time period would indicate that a leak is present in the system.

**NOTE :** If an alternate air source (e.g., an air cylinder or a belt driven air pump) is used instead of a compressor, the air system will have to be leak tested with a pressure gauge and a shut-off valve in series before the solenoid input.

- If a leak is found to be present, spray a soap and water mixture onto all air fittings in the system while the compressor is fully charged. Bubbles should appear at any leak points.
- Check that leaky fittings have been adequately tightened.
- Disassemble, clean threads, and reapply thread sealant if leaking persists.

### 7.2 Testing the Air Locker Actuation

To test that your air system, electrical system, and your *Air Locker* differential is functioning correctly:

- Support the vehicle such that the wheels are free to rotate (e.g., on axle stands, a chassis hoist, etc.)
- Leave the parking brake off, the transmission in neutral, and the *Air Locker* switch 'OFF'.
- Turn the ignition to the 'ON' position (leaving the motor off). The large illuminating symbol on the *Air Locker* switch cover should be 'OFF'.
- Turn the compressor (or alternate air source) on to charge the air supply up to its maximum pressure.

## 7 Testing & Final Assembly

- Rotate one wheel by hand.
- The wheel should rotate freely and the opposite wheel should be turning in the opposite direction without any resistance or mechanical noise from within the differential.
- Turn the *Air Locker* switch to the 'ON' position. The illuminated symbol on the switch cover should light up.
- Rotate the same wheel again.
- Both wheels should rotate together.
- Turn the switch off again.
- Rotate the same wheel.
- The wheels should again rotate in opposite directions.

### 7.3 Filling the Differential

**NOTE :** Consult the *ARB Air Locker Operating & Service Manual* for recommendations on differential lubricant specifications.

- Remove the filler plug.
- Refill the differential until level with the filler hole.
- Rotate the differential center 2 full turns.
- Check the oil level and add oil if necessary.
- Replace filler plug (apply thread sealant to filler plug before inserting if it is a threaded type plug).
- Wipe differential housing clean of any oil or grease which may collect dirt or other abrasive particles.

## 7 Testing & Final Assembly

### 7.4 Post-Installation Check List

Now that the *Air Locker* installation has been completed, ARB recommends that you take the time to complete the following check list just to insure that you haven't missed any of the vital steps.

- The air system has been leak tested.
- Thread locking compound was used on the ring gear bolts.
- All torque settings comply with the vehicle manufacturer's specs and were set with an accurate torque wrench.
- Differential fluid complies with ARB recommendations and has been filled to the correct level.
- All air lines and wiring have been securely cable tied to resist snagging.
- Switch(es) have been securely mounted within operator reach, yet well away from danger of accidental engagement.
- Switch(es) function properly and illuminate to indicate that *Air Locker(s)* are engaged.
- All operators who are to use the *Air Locker* have read, and fully understand the *ARB Air Locker Operating & Service Manual*.
- The *Air Locker* Warning Sticker has been located within close proximity of the actuator switch(es).

INSTALLATION PERFORMED BY:

\_\_\_\_\_

DATE OF INSTALLATION:

\_\_\_\_\_

ODOMETER READING:

\_\_\_\_\_

ARB AIR LOCKER SERIAL No:

\_\_\_\_\_





## 8 Parts List

**RD253**

Toyota 9.5" RR, 32 SPL, OE Locker Replacement

### 8.1 Exploded Assembly Diagram (See itemized parts list overleaf)

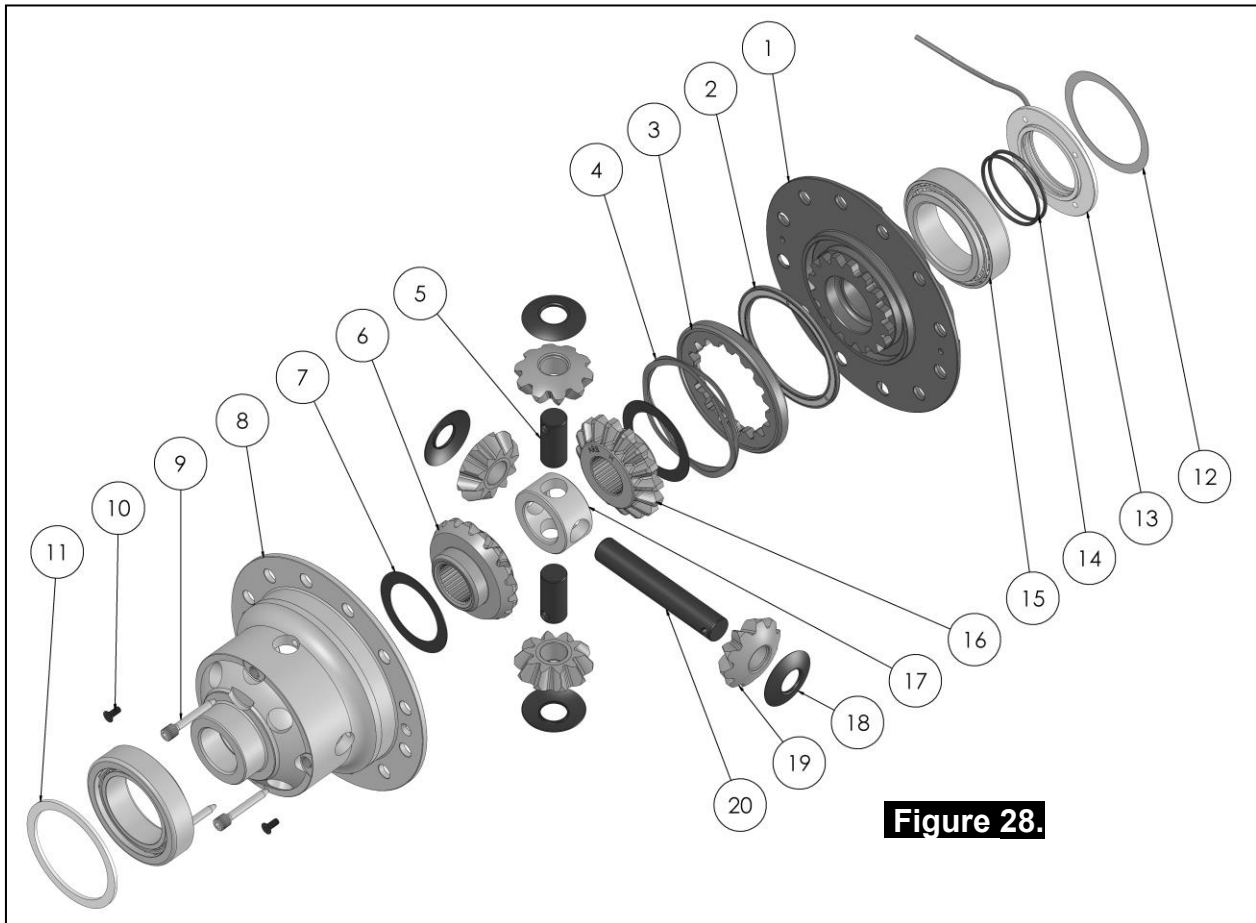

**Figure 28.**

### 8.2 Specifications

Axle Spline	32 tooth, Ø34.8mm [1.37"]
Ratio Supported	All
Ring Gear ID	140.95mm [5.55"]
Ring Gear OD	225mm [8.86"]
Ring Gear Bolts	12 bolts on Ø162.5mm [6.40"]
Ring Gear Torque	137Nm [101 ft-lb]
Backlash	0.15-0.25mm [0.006-0.010"]
Bearing Cap Torque	113Nm [83 ft-lb]

## 8 Parts List

### 8.3 Itemized Parts List

(See exploded diagram figure 28.)

ITEM #	QTY	DESCRIPTION	PART #	NOTES
01	1	FLANGE CAP KIT	027355SP	
02	1	BONDED SEAL	160702SP	
03	1	CLUTCH GEAR & WAVESPRING KIT	050906SP	
04	1	WAVESPRING	150706SP	
05	2	SHORT CROSS SHAFT	060403SP	
06	1	SIDE GEAR	SEE NOTE	2
07	2	SIDE GEAR THRUST WASHER	SEE NOTE	3
08	1	DIFFERENTIAL CASE	013055SP	
09	1	RETAINING PIN SET (PK OF 4)	120601SP	
10	1	COUNTERSUNK SCREW (PK OF 2)	200213SP	
11	1	MASTER SHIM	NOT SUPPLIED	
12	1	SHIM KIT	SHK005	
13	1	SEAL HOUSING KIT	081829SP	
14	1	SEAL HOUSING O-RINGS (PK OF 2)	160248-2	1
15	1	TAPERED ROLLER BEARING	NOT SUPPLIED	
16	1	SPLINED SIDE GEAR	SEE NOTE	2
17	1	SPIDER BLOCK	070201SP	
18	4	PINION THRUST WASHER	SEE NOTE	3
19	4	PINION GEAR	SEE NOTE	2
20	1	LONG CROSS SHAFT	060204SP	
*	1	BHF BLANKING PLATE	220225	
*	1	BRAKE LINE MOUNT PLATE	220227	
*	1	BULKHEAD FITTING KIT (BANJO TYPE)	170114	4
*	1	AIR LINE (6mm DIA X 6m LONG)	170314SP	4
*	1	SOLENOID VALVE (12V)	180103	
*	1	CABLE TIE (PK OF 25)	180305	
*	1	OPERATING & SERVICE MANUAL	210200	
*	1	INSTALLATION GUIDE	2102253	
*	1	SWITCH RR LOCKER	180224SP	

\* *Not illustrated in exploded view*

### NOTES

- 1 For replacement O-rings use only BS140 Viton 75.
- 2 Available only as complete 6 gear set # 728H201
- 3 Available only as complete thrust washer kit #730H01
- 4 All diffs produced before serial #17070001 came with 5mm air connection system.  
For information contact ARB.