



# RD275

**MITSUBISHI TRITON, REAR, 31 SPLINE**

---

**AIR OPERATED  
LOCKING DIFFERENTIAL  
INSTALLATION GUIDE**

---

No liability is assumed for damages resulting in the use of the information contained herein.  
ARB Air Locker Locking Differentials and Air Locker are trademarks of ARB Corporation Limited.  
Other product names used herein are for identification purposes only and may be trademarks of their respective owners.

---

# **ARB 4x4 ACCESSORIES**

## **Corporate Head Office**

**42-44 Garden St  
Kilsyth, Victoria  
AUSTRALIA  
3137**

**Tel: +61 (3) 9761 6622  
Fax: +61 (3) 9761 6807**

**Australian enquiries  
North and South American enquiries  
Other international enquiries**

**sales@arb.com.au  
sales@arb.com.au  
exports@arb.com.au**

---

**www.arb.com.au**

## Table of Contents:

<b>1</b>	<b>Introduction</b>	<b>3</b>
1.1	Pre-Installation Preparation	3
1.2	Tool-Kit Recommendations	4
<b>2</b>	<b>Removing the Existing Differential</b>	<b>5</b>
2.1	Vehicle Support	5
2.2	Differential Fluid Drain	5
2.3	Removing the Axle	5
2.4	Marking the Bearing Caps	6
2.5	Checking the Current Backlash Amount	7
2.6	Spreading the Differential Housing	8
<b>3</b>	<b>Bench Measurement</b>	<b>9</b>
3.1	Approximate Backlash Shimming	9
3.2	Calculation & Selection of Shims	12
<b>4</b>	<b>Installing the Air Locker</b>	<b>13</b>
4.1	Mounting the Ring Gear	13
4.2	Installing the Carrier Bearings	15
4.3	The Bulkhead Port	16
4.4	Assembling the Seal Housing	20
4.5	Calculation & Selection of Pre-Load Shims	21
4.6	Final Air Locker Assembly	22
4.7	Final Backlash Checking	23
4.8	Profiling the Seal Housing Tube	25
4.9	Setting up the Bulkhead Fitting	27
4.10	Bench Testing the Air Locker	28
4.11	Reinstalling the Axles	29
<b>5</b>	<b>Installing the Air System</b>	<b>29</b>
5.1	Mounting the Solenoid	29
5.2	Running & Securing the Air Line	32
5.3	Connection to the Bulkhead Fitting	33
<b>6</b>	<b>Mounting &amp; Connecting the Electrical System</b>	<b>34</b>
6.1	Mounting the Actuator Switch(es)	34
6.2	Wiring the Actuator System	35
<b>7</b>	<b>Testing &amp; Final Assembly</b>	<b>39</b>
7.1	Leak Testing	39
7.2	Testing the Air Locker Actuation	40
7.3	Re-Sealing & Filling the Differential	41
7.4	Disable Diff Lock Switch & Actuator Plug Modification	42
7.5	Post-Installation Check List	48
<b>8</b>	<b>Parts List</b>	<b>50</b>
8.1	Exploded Assembly Diagram	50
8.2	Specifications	50
8.3	Itemized Parts List	51



# 1 Introduction

## **IMPORTANT :**

**BEFORE ATTEMPTING TO DISMANTLE YOUR VEHICLE FOR THIS INSTALLATION, PLEASE READ THIS INSTALLATION GUIDE IN ITS ENTIRETY, AS WELL AS ALL APPLICABLE SECTIONS OF YOUR VEHICLE MANUFACTURER'S SERVICE MANUAL.**

### 1.1 Pre-Installation Preparation

This booklet is to be used in conjunction with your vehicle manufacturer's service manual. ARB endeavors to account for every possible variation in vehicle model when publishing its installation guides, and guides are updated regularly as new model information becomes available, however, the rapid and globally varied release of some vehicles makes it difficult to insure that your vehicle model has been accurately accounted for. In the case of any technical discrepancies between this guide and your service manual, we strongly advise that you adhere to the specifications and techniques as documented in your service manual.

Although your *ARB Air Locker* comes complete with all the step by step instructions you will need to supplement your vehicle manufacturer's service manual and install your new differential, ARB recommends that you have your *Air Locker* installed by a trained professional. Many ARB distributors around the world have been fully instructed in *Air Locker* installations by ARB, and have gained a wealth of experience and skill from years of performing similar installations.

Once you begin this installation your vehicle will be immobile until all steps of the installation are complete. Make sure your *Air Locker* kit is the correct model for your vehicle and that it contains all of the parts listed on back cover of this booklet. Also be sure you have appropriately equipped yourself with all the necessary tools, parts, and materials to complete this installation (see section 1.2 *Tool-Kit Recommendations*), and that you have allowed for an appropriate amount of vehicle down time.

#### **HINT :**

Place a ✓ mark inside each of the  symbols as you complete each step. It is very important NOT to miss any of the steps!

# 1 Introduction

## 1.2 Tool-Kit Recommendations

Below is a list of tools and supplies you may need to complete this installation. Requirements for your vehicle may vary. Please consult your vehicle service manual for additional recommendations.

### 1.2.1 Tools

---

- Standard automotive sizes (metric and/or imperial) of sockets, wrenches, Allen keys, and drills.
- A dial indicator or other suitable measuring tool for checking ring & pinion backlash.
- A standard automotive feeler gauge.
- Automotive brake tubing cutters to cut the steel tubing.
- A razor knife to cut the nylon tubing.
- A differential housing spreader, to facilitate removal and installation of the carrier. (e.g. ARB Spreader #0770003)
- A torque wrench. (See vehicle manual for required torque range.)
- A lubricant drain reservoir.
- Suitable measuring tools to measure a differential for pre-load and/or backlash shimming. (See Section 3 Bench Measurement).
- A 11.2mm [7/16"] drill and ¼" NPT tap for bulkhead fitting installation.
- An automotive bearing puller (e.g. ARB Bearing Puller #0770001) or a differential carrier bearing puller.
- A bearing press or arbor press.
- A suitable shim driver (e.g. ARB Shim Driver #0770004)
- A soft hammer (e.g. raw hide or nylon)

### 1.2.2 Supplies

---

- Thread lubricant/sealant compound (e.g., LOCTITE #567 Teflon Paste)
- Thread locking compound (e.g., LOCTITE #272)
- A replacement gasket, or gasket sealant, for your third member.
- A sufficient volume of differential oil to completely refill your housing. (see the *ARB Air Locker Operating and Service Manual* for recommended lubricants)
- A soap and water mixture to test for air leaks.

## 2 Removing the Existing Differential

### 2.1 Vehicle Support

- Safely secure the vehicle on a hoist. We recommend supporting the vehicle on a chassis hoist to keep the differential area at a convenient working height and to leave the wheels and axles free to be rotated and removed.
- Once supported off the ground, release the parking brake and leave the vehicle in neutral. Chock the wheels if necessary.

### 2.2 Differential Fluid Drain

- Clean around the differential drain plug to prevent dirt from entering the differential.
- Position a fluid drain reservoir under the differential and loosen the differential drain plug.
- Completely drain all differential fluid.
- Once drained, reinstall the drain plug finger tight to prevent drips coming out of the housing and dust getting in.

**HINT :** This is a good time to check for metal particles in your oil and in the bottom of the housing which may indicate a worn bearing or differential component.

### 2.3 Removing the Axle

#### **IMPORTANT :**

Collision damage or heavy off-road use of your vehicle in the past may have resulted in some degree of bending in the axle. Any misalignment of the axle tubes may result in excessive wear and/or failure of your differential and axle shafts. ARB strongly recommends that you have your axle assembly inspected for concentricity and straightness before installing your *Air Locker*.

- Remove the axles according to your vehicle's service manual.
- Disconnect the drive shaft from the flange of the differential.
- Remove the third member from the differential housing. Refer to your vehicle's service manual.

## 2 Removing the Existing Differential

### 2.4 Marking the Bearing Caps

- Using a small pointed center punch, gently mark the bearing caps in a way that will enable you to know which cap is 'LEFT' and which cap is 'RIGHT', which way is 'UP' and which way is 'DOWN'.  
(Fig.1.)

**HINT :** Many installers choose to make one punch mark on the left hand side of the left hand bearing cap and one similar punch mark on the housing at close proximity to the cap mark. The right hand side is then designated with two punch marks on the right hand side of the cap and two similar punch marks on the housing.



## 2 Removing the Existing Differential

### 2.5 Checking the Current Backlash Amount

#### **IMPORTANT:**

This step is a precautionary measure recommended by ARB due to the fact that some after market ring and pinion sets have been manufactured to run with different backlash settings than those specified by your vehicle manufacturer. Although ARB must recommend you set backlash according to your service manual guidelines, we also advise that you compare the backlash measurements taken here to the recommended backlash settings in your vehicle service manual. Measurements found to be outside of your service manual recommendations may indicate the need to deviate from those settings in order to achieve quiet running with a good contact mark.

Refer to your vehicle service manual or your local authorized ARB installer for more information.

- Set a depth indicator on one of the ring gear teeth as in Fig. 2.

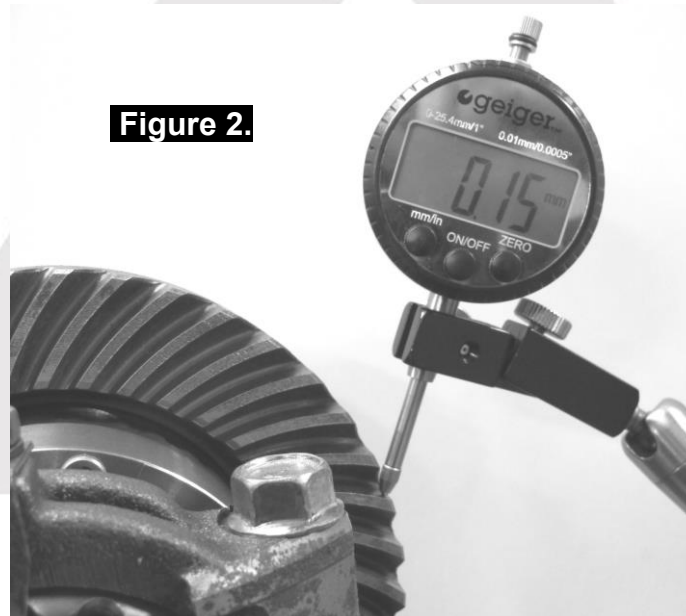

- While supporting the pinion gear by holding the drive shaft, rotate the differential in both directions while observing the maximum variation in depth from the indicator (i.e., the highest value minus the lowest value). This value is referred to as the ring and pinion backlash.
- Rotate the differential center 90° and measure again for accuracy.
- Record the average of all measurements.

## 2 Removing the Existing Differential

### 2.6 Spreading the Differential Housing

#### **IMPORTANT:**

Spreading the differential housing with a differential case spreader is a step which is critical to set up bearing pre-load when a differential is installed. Improper pre-load will result in undue bearing wear, increased stresses in the differential center, increased running noise, and ultimately, ring and pinion gear damage.

- Unbolt and remove the bearing caps from the differential housing.

**HINT :** Be sure not to mix up the left and right hand bearing caps. Later it will be necessary to know which cup came from which bearing and which shim came from which side.

- Setup the differential spreader and a dial indicator and carefully spread the differential housing (Fig.3.) just enough to remove the differential carrier (Refer to your vehicle's service manual).

**NOTE :** Never spread the housing more than 0.50mm [0.020"].

- Once the housing has been adequately spread, the differential may be removed by pulling forward on the differential carrier.



- Release all spreader tension immediately after removing the differential carrier.

## 3 Bench Measurement

### 3.1 Approximate Backlash Shimming

In order to reproduce a similar pre-load and ring and pinion backlash in your *Air Locker* to that of your original differential, measurements need to be taken so that a shim thickness can be calculated.



- Secure the differential to a work bench.
- Remove the bolts that hold the ring gear in place.
- Using a plastic or copper hammer, tap in a circle around the ring gear to separate it from the differential carrier.
- Remove the original bearings from the differential center using a bearing puller (Fig.4.).

**NOTE :** For Triton equipped with a factory locker, the bearing from diff case side is difficult to be removed without damaging it. Source the bearing (part no. NSK HR32910J or Mitsubishi part no. 38440A010P) through bearing wholesaler or Mitsubishi as a spare bearing before attempting removal.

**NOTE :** Keep the bearings and shims separated so that they can be identified as to which end of the differential they came from.

- Examine the bearing cups and cones from Fig.5. for damage or wear and, if necessary, discard them and replace with the same size and type of bearings.

### 3 Bench Measurement

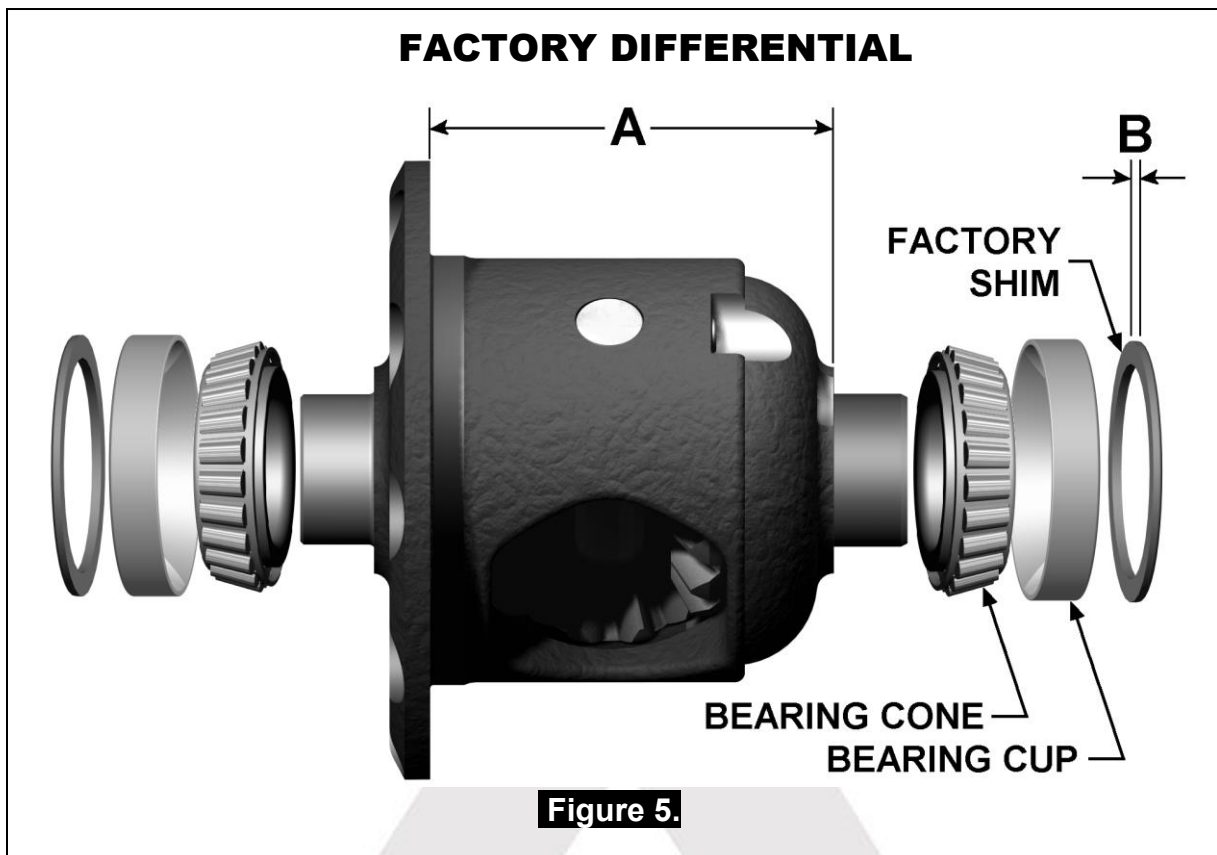

- Using a caliper or similarly accurate measurement method (i.e., able to take accurate measurements within 0.04mm [0.0015"]), measure the distance from the bearing shoulder to the ring gear mounting face (shown as 'A' in Fig.5.) and record this measurement as 'A'.
- Measure the thickness of the factory shim removed from the case side (right hand side) of the differential carrier (shown as 'B' in Fig.5.) and record this measurement as 'B'.
- Measure the distance from the *Air Locker* bearing shoulder to the ring gear mounting face (shown as 'C' in Fig.6.) and record this measurement as 'C'.

### 3 Bench Measurement

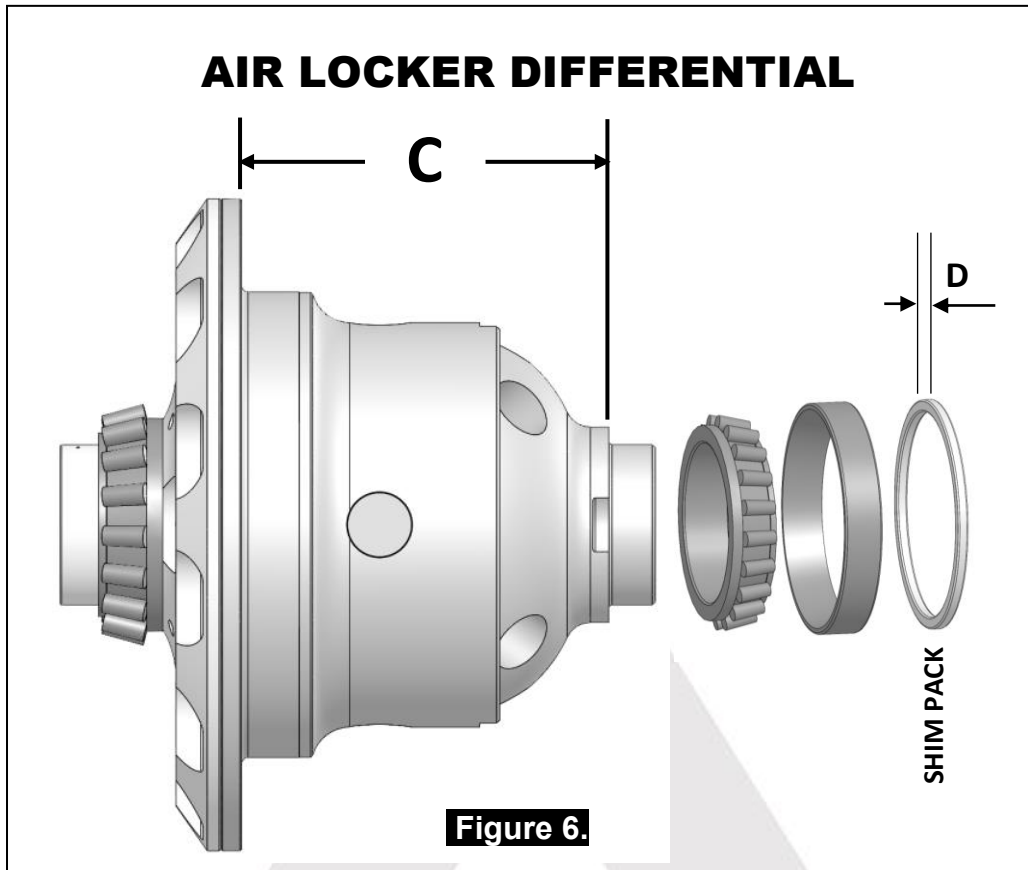

## 3 Bench Measurement

### 3.2 Calculation & Selection of Shims

Ideally, the measurement you recorded as 'A' from the existing differential will closely match 'C' on the *Air Locker* (within 0.1mm [0.004"]). However, quite often these measurements will vary slightly between one factory differential and the next.

If this is the case you must create a new shim pack thickness by using the measurements you recorded earlier to find a desired measurement for 'D' in Fig.6.

Use the following calculation:

$$A + B - C = D$$

**HINT :** If your calculations are correct then the following equation will also be true:

$$A + B - C - D = \text{ZERO}$$

To make a shim pack to match the measurement you calculated as 'D' you can:

- Re-use the factory master shim and select additional shims from the shim kit SHK013 supplied with your Air Locker kit
- Purchase new factory shims at the desired thickness.
- Use a universal shim kit available from most drive train specialists.

**NOTE :** NEVER machine the *Air Locker*.  
NEVER re-use any shims which are damaged or worn.

## 4 Installing the Air Locker

### 4.1 Mounting the Ring Gear

- Apply a thin film of high-pressure grease to the ring gear shoulder of the Air Locker to prevent seizing.
- Thoroughly clean any thread locking compound or other foreign matter from the holes of the ring gear, the threads of the ring gear bolts, the mating surfaces of the ring gear and the Air Locker flange.

**HINT :** Rubbing the ring gear mounting face with a flat oil stone before installation will remove any high spots around the threads.

- Heat the ring gear to between 80 and 100°C (175 - 212°F) in hot water or in an oven to slightly expand the gear and facilitate assembly.

**NOTE :** **NEVER HEAT GEARS WITH A FLAME!** This could damage the hardened surface of the gear and result in premature wear or failure.

- Dry the ring gear with compressed air (if wet), paying particular attention to the threaded holes.
- Install the ring gear onto the Air Locker by aligning the tapped holes and then gently tapping it around in a circle with a soft mallet or hammer.

**NOTE :** Avoid using the bolts to pull down the ring gear as this puts excess strain on the bolts and the differential flange.

- Apply a thread locking compound to the thread of each ring gear bolt before inserting it.

**NOTE :** Do not apply threading compound directly into the threaded hole as this could prevent the bolt from reaching its full depth.

- Tighten the ring gear bolts in a star pattern with a torque wrench (Fig.7.) set to your vehicle manufacturer's specified torque.

## 4 Installing the Air Locker

Figure 7.



## 4 Installing the Air Locker

### 4.2 Installing the Carrier Bearings

- With the *Air Locker* well supported in an arbor press, apply a thin film of high pressure grease to both bearing journals of the *Air Locker* to prevent seizing.
- Allocate the correct bearings to their respective sides on the *Air Locker*.
- Press the ring gear side (left hand side) tapered roller bearing cone onto the bearing journal of the *Air Locker* until the bearing seats firmly against the bearing journal shoulder (Fig.8.).

**NOTE :** Never re-use any bearings which are damaged or worn.

- Invert the *Air Locker* and press the remaining bearing cone onto the case side (right hand side) bearing journal until the bearing seats firmly against the bearing journal shoulder.



Figure 8.

## 4 Installing the Air Locker

### 4.3 The Bulkhead Port

An air line port must be provided through the differential housing to mount the bulkhead fitting into.

#### **IMPORTANT:**

For the vehicle assembled with an OE differential locker, there is no need to drill the bulkhead port, skip to 4.3.2.

#### 4.3.1 Drilling and Tapping the Bulkhead Port

- Mark a spot on the right hand side (opposite the ring gear) toward the top in an area that will be well clear of the Air Locker body, the ring gear, and any other obstructions that could snag the seal housing tube. (Fig. 9.-Fig.13.)

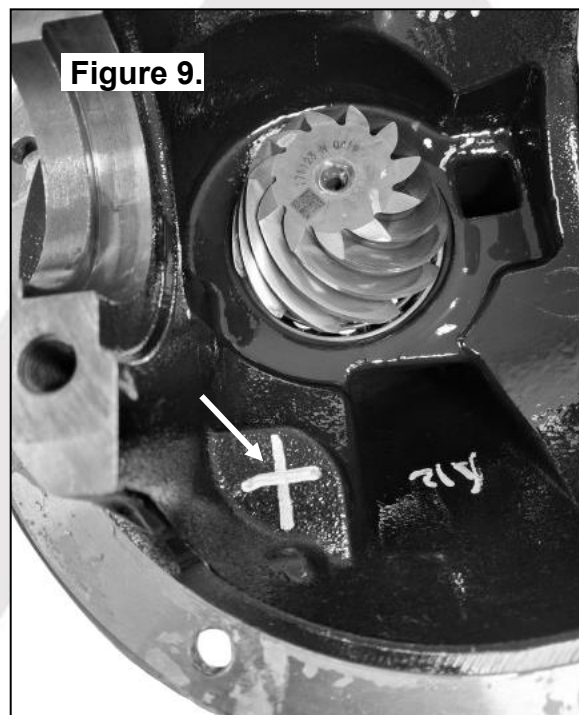

## 4 Installing the Air Locker

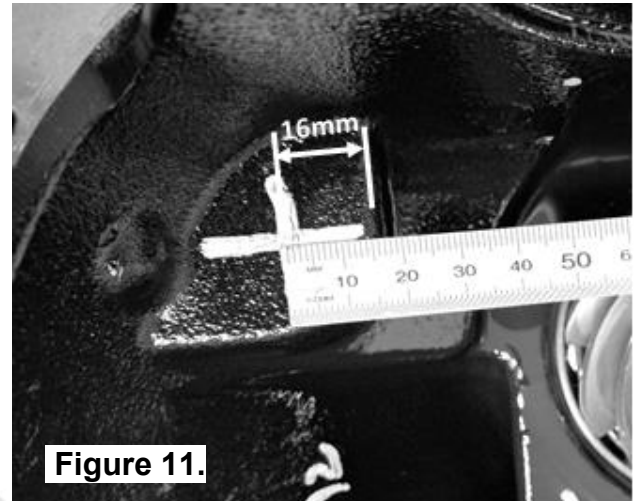
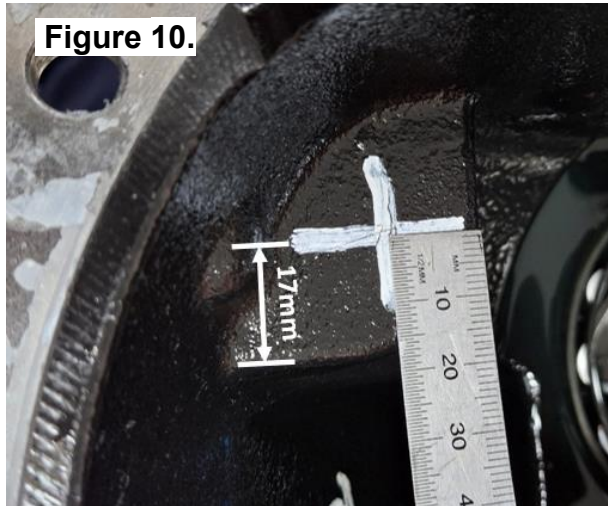

- Cover the drive pinion area with a rag to protect it from metal filings.
- Secure the differential housing to the work bench.
- Drill an 11.2mm [7/16"] diameter hole through the differential housing square to the outside surface.
- Tap the hole from the outside using 1/4"NPT thread tap.
- Remove any sharp edges from the hole that may chip off and fall into the housing.
- Very carefully, remove the rags and inspect with a service light inside the housing to insure no metal filings are left behind.

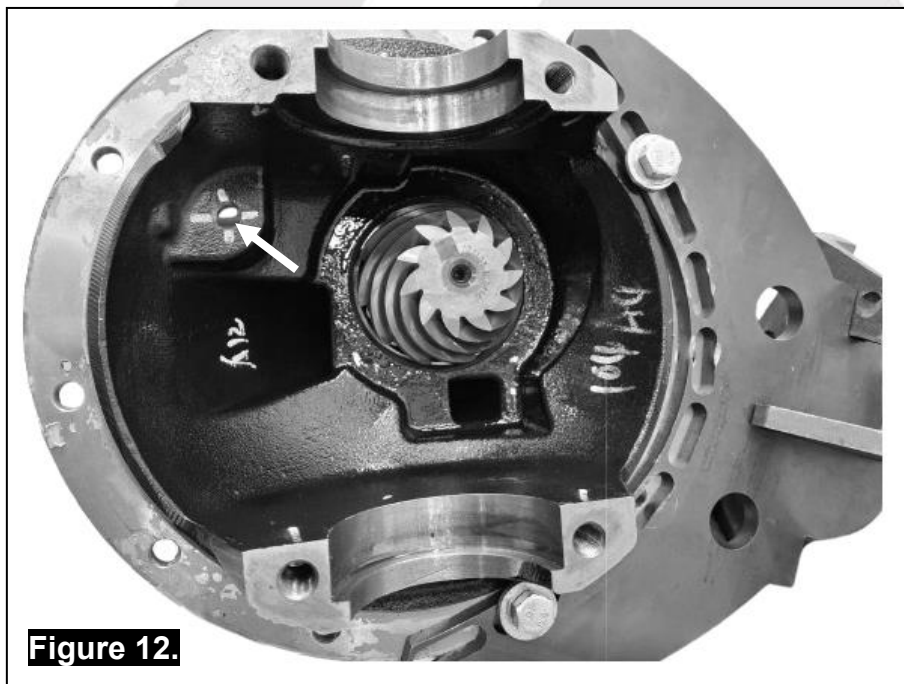

## 4 Installing the Air Locker

**Figure 13.**

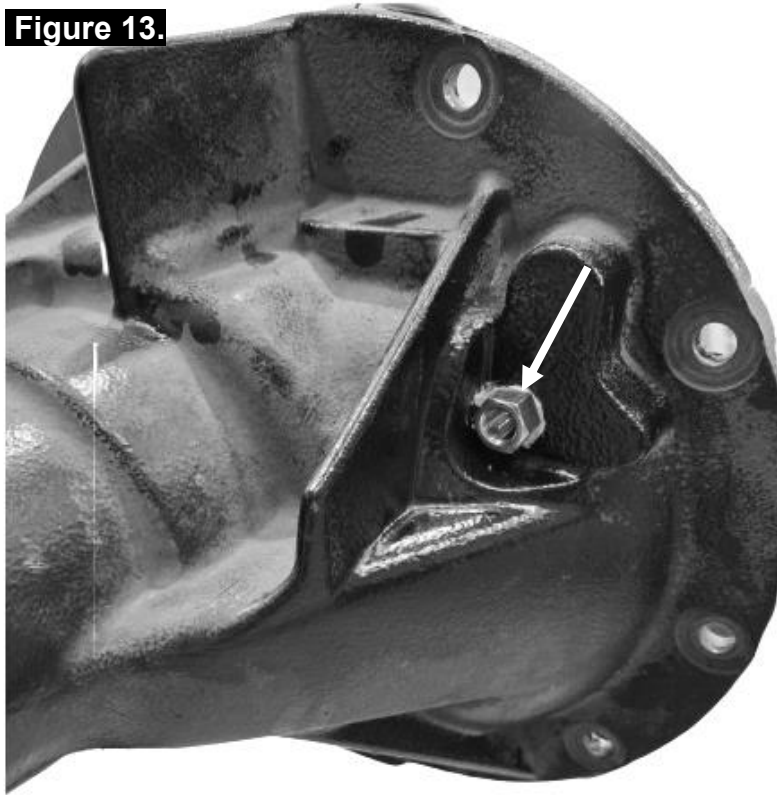

### 4.3.2 Installing the Threaded Bulkhead Seat (supplied)

- Remove the OE locker connector shown in Fig.14.

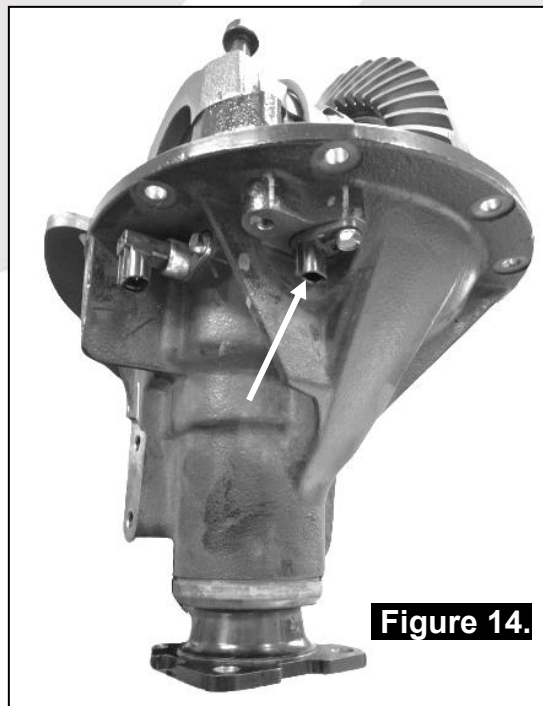

## 4 Installing the Air Locker

- Apply gasket sealant to both the outside of the bulkhead seat and inside of the port left by the removal of the OE locker connector, then insert the bulkhead seat into the port (Fig.15.).

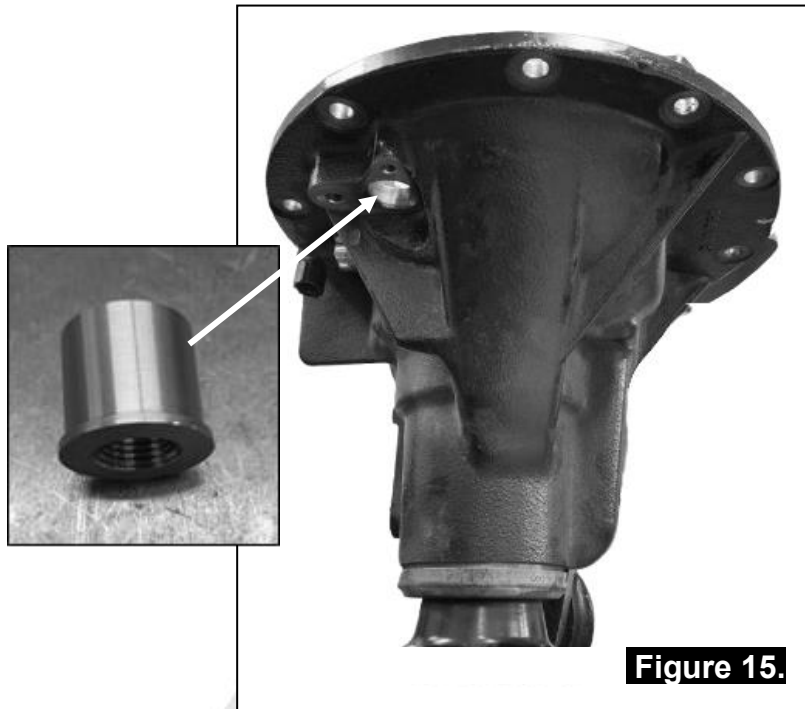

- Install the flat washer (supplied) against the bulkhead seat by re-using the factory bolt.
- Wipe the area clean of any excess sealant.

## 4 Installing the Air Locker

### 4.4 Assembling the Seal Housing

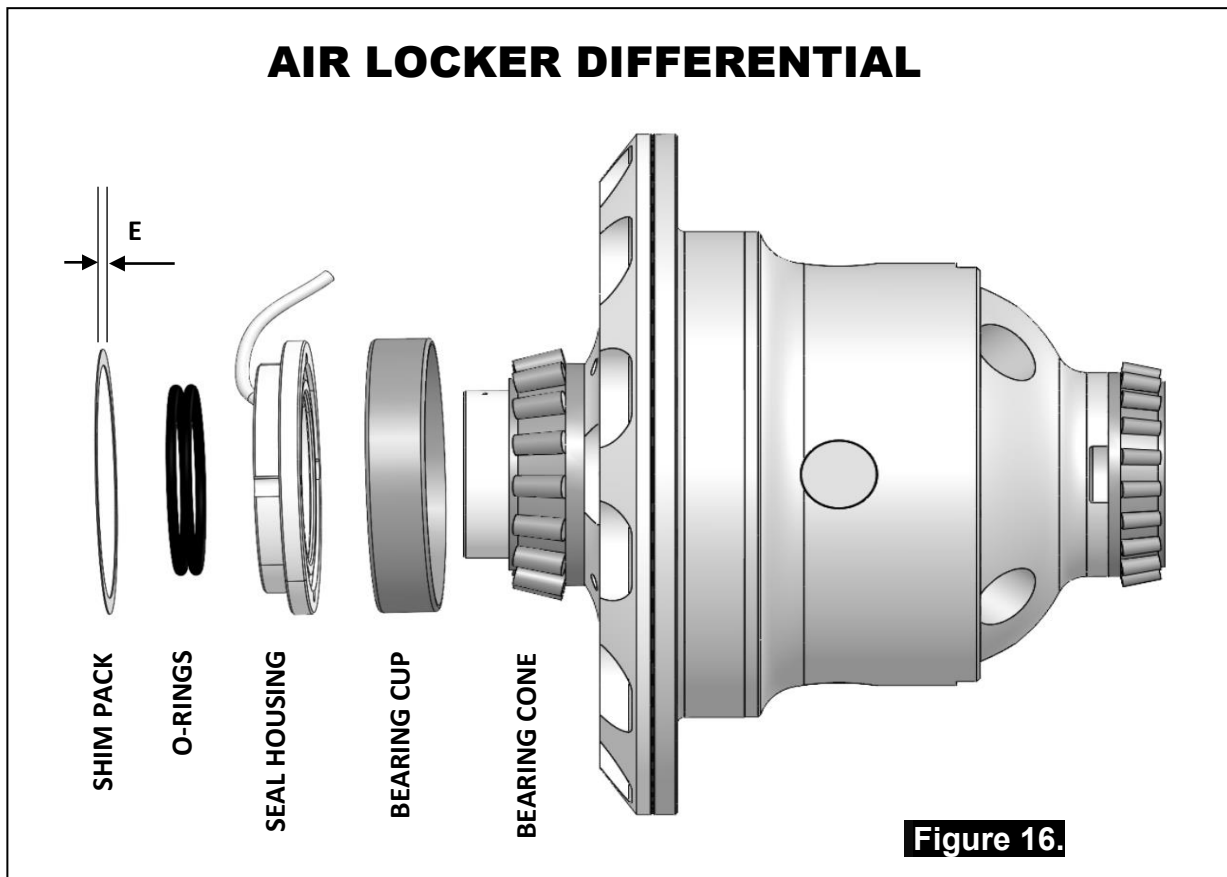

- Make sure the grooves and airway of the seal housing are clean and free from any contaminants (e.g. water, dirt, metal filings, etc.).
- Inspect the seal housing O-rings (supplied) for dirt, damage or other conditions which might cause leaks.
- Generously lubricate the O-rings with oil prior to assembly, then insert them into the grooves of the seal housing.

**NOTE :** When assembling the O-rings, be careful not to leave them twisted when seated in the grooves as this could cause excessive wear and leakage.

- Lubricate the seal housing running surface on the Air Locker carrier with oil. Assemble the bearing cup onto the left-hand side of the Air Locker.
- Carefully install the seal housing by sliding it all of the way onto the bearing journal with a gentle twisting motion. This will allow the O-rings to engage gently.

## 4 Installing the Air Locker

**NOTE :** A twisting motion (i.e., a slight rotation while pressing the seal housing on) will allow the O-rings to engage gently and prevent them from twisting. Twisted O-rings will result in pre-mature O-ring wear and oil contamination in the air system due to the helical shape formed by the O-ring mould line.

### 4.5 Calculation & Selection of Pre-Load Shims

In order to preload the tapered roller bearings in your *Air Locker*, measurements need to be taken so that a value can be calculated for the total shim thickness 'E' in Fig.16.

- Hold the bearing cup in place, insert and hold the *Air Locker* into the differential housing.
- Insert the shim pack determined earlier as 'D' between the bearing cup and the differential housing (right hand side as shown in Fig.6.)
- Push the *Air Locker* hard across against the bearing and shim pack 'D', and measure the gap between the end of the seal housing assembly and the bearing seat of the differential housing with a feeler gauge.
- Record this measurement.

**NOTE :** This 'end float' measurement determines the shim thickness necessary to achieve 'neutral pre-load'. Adding more shim than this measurement becomes the actual 'pre-load'.

- Consult your vehicle manufacturer's service manual to determine the carrier bearing preload amount specified for your vehicle.

**NOTE :** If your service manual specifies preload in terms of a torque value measured off the drive pinion flange, then assume a preload amount of 0.25mm [0.01"] for the following calculations. Once you have assembled the housing to check the final backlash (Refer to Section 4.7 *Checking the Backlash*) you should verify that your preload is correct using a torque wrench and your service manual's table of values.

- Add the specified pre-load amount to the measurement taken with the feeler gauge to determine a shim amount for 'E' in Fig.16.

## 4 Installing the Air Locker

### PRE-LOAD + END FLOAT = SHIM PACK 'E'

- Select suitable shims from the supplied shim kit SHK008 to make up a shim pack 'E' of this thickness.
- Remove shim pack 'D' from the case side (right hand side) and put aside for the time being.

### 4.6 Final Air Locker Assembly

- Spread the differential housing again (Refer to section 2.6).
- Assemble the shim pack 'E' onto the seal housing flange on the same side as the seal housing tube's solder joint.
- Reinstall the *Air Locker* into the differential housing.
- Using a shim driver, lightly tap shim pack 'D' into the case side (right hand side) between the bearing cup and the differential housing (Refer to Fig.17.).

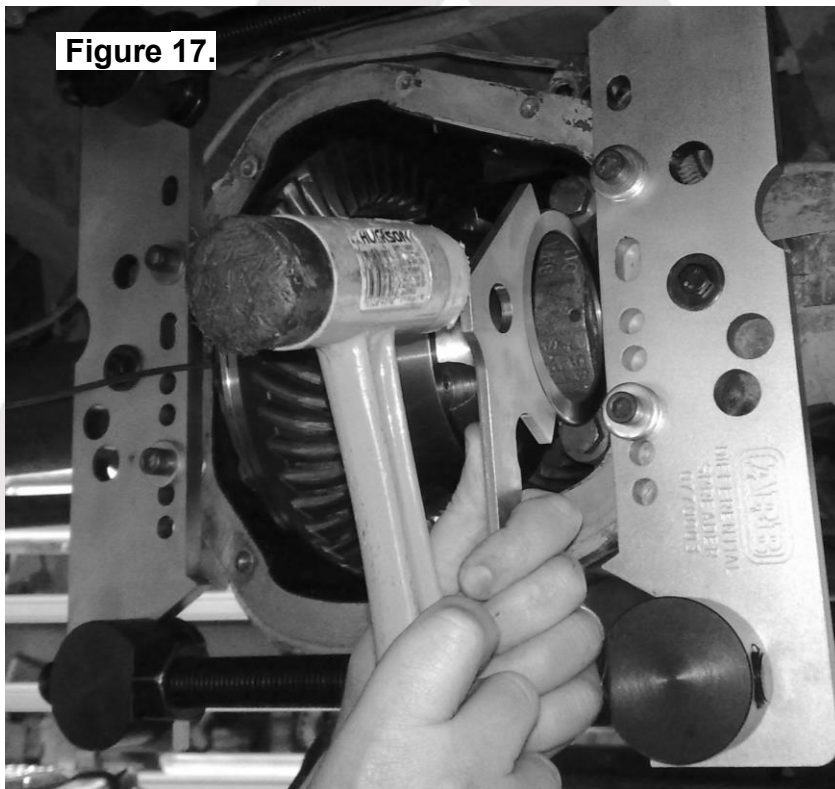

**NOTE :** If the carrier is too difficult to install with the added shim pack then the spreader tension may need to be increased. Do not spread the housing more than 0.50mm [0.020"].

## 4 Installing the Air Locker

- Release all spreader tension once the shims and *Air Locker* are fully installed.
- Check that some backlash can be felt between the ring and pinion gears. No backlash would be an early indication of incorrect shim thickness.

### 4.7 Final Backlash Checking

- Insert the bearing caps oriented as they were marked before they were removed, and tighten with a torque wrench to the torque specified in your vehicle manufacturer's service manual.
- Set a depth indicator on one of the ring gear teeth as in Fig.18.
- While supporting the pinion gear by holding the drive flange, rotate the differential in both directions while observing the maximum variation in depth from the indicator (i.e., the highest value minus the lowest value). This value is referred to as the ring and pinion backlash.
- Rotate the differential center 90° and measure again for accuracy.

**Figure 18.**

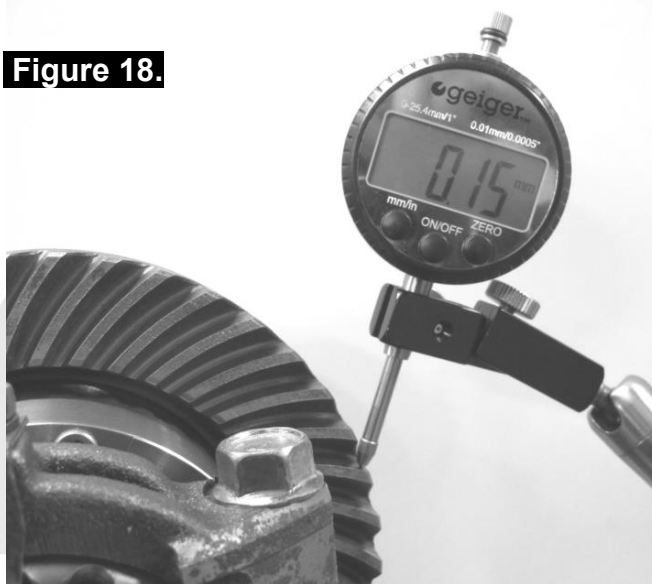

- Refer to your vehicle service manual for the specified maximum and minimum amounts of backlash. If the backlash is not within the specification, then the differential will have to be removed and re-shimmed.

## 4 Installing the Air Locker

### 4.7.1 Re-Shimming the Backlash

---

**NOTE :** This step is only necessary when adjusting for incorrect backlash.

- Reapply the spreader to the differential housing.
- Remove the bearing caps.
- Remove the differential.
- To decrease the amount of backlash, reduce the shim thickness 'D' (Fig.6.) and increase the shim thickness 'E' (Fig.16.) by the same amount. Reverse this step to increase the backlash.
- Remount the differential as before.
- Release spreader tension.
- Check backlash again as before.

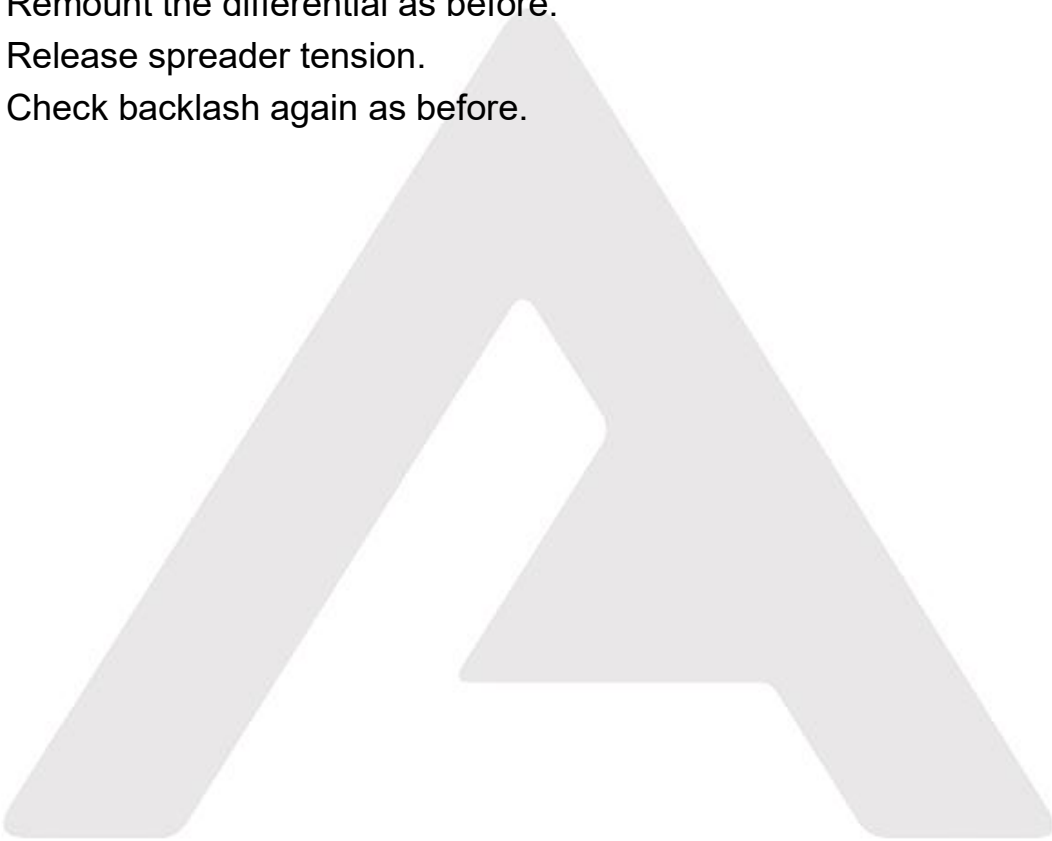

## 4 Installing the Air Locker

### 4.8 Profiling the Seal Housing Tube

The seal housing tube will need to be profiled so that it is clear of both the *Air Locker* as well as the axle housing.

- Without using sharp, jagged tools such as pliers (usually your hands are the best tool for this job), bend the seal housing tube so that it closely follows the profile of the differential. Refer to Fig.19., Fig.20. and Fig.21. for recommended profile.
- Trim the tube to length using the automotive brake line cutters.



## 4 Installing the Air Locker

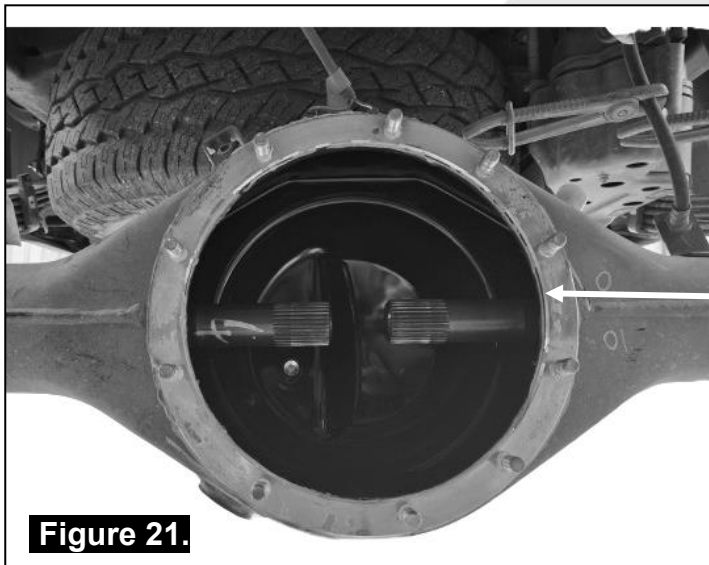
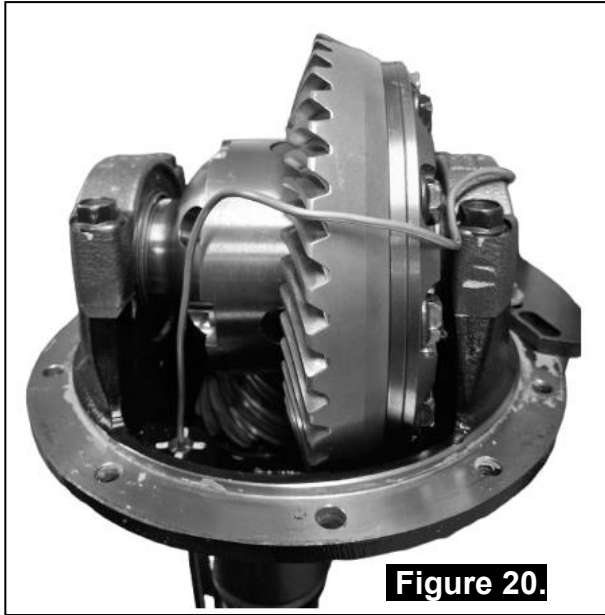

**NOTE :** Ensure the tube will not interfere with the opening of the banjo when reinstalling the third member ( as shown in Fig. 21.). Cut a small notch on the bearing cap if necessary.

- Check that the contour of the tube will not interfere with the Air Locker or the ring gear.

**NOTE :** It is a good idea to keep the tube away from the *Air Locker* and any other part of the differential casting as any contact due to vibration or shock may wear the tube and eventually cause a leak.

## 4 Installing the Air Locker

### 4.9 Setting Up the Bulkhead Fitting

**NOTE :** Use an automotive brake line tubing cutter to cut the seal housing tube. Never use a hacksaw for trimming the steel tube as this will leave metal fillings in the air system.

- Apply thread sealant to the outside threads of the bulkhead body.
- Screw the bulkhead body into the tapped hole or the bulkhead seat threaded hole, and lightly tighten using a 14mm [9/16"] spanner.
- Wipe the area clean of any excess thread sealant (inside and outside of the housing).
- Insert the free end of the seal housing tube into the bulkhead fitting until it protrudes approximately 8mm [5/16"] through the other side.
- From the outside of the housing, assemble one of the small O-rings over the top of the short length of seal housing tube protruding through the bulkhead fitting.
- Install the brass spacer.
- Install the second small O-ring after the spacer.
- While holding the seal housing tube into the bulkhead fitting, insert the chamfered end of the center compression nut over the extended tube as shown in the assembly diagram (Fig.22.), and screw it into the bulkhead body, and tighten using Pozidriv #3 screwdriver.

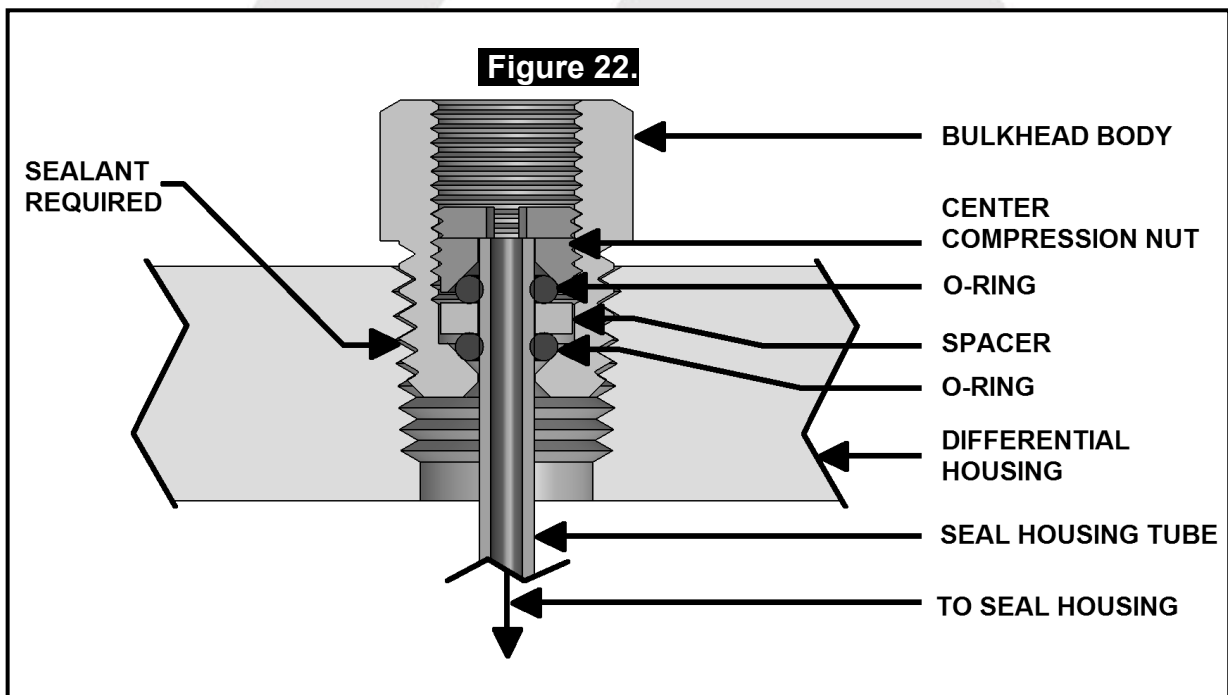

## 4 Installing the Air Locker

**NOTE :** Make sure the seal housing tube is all of the way into the center compression nut while you are tightening it.

**NOTE :** Firmly tighten the center compression nut so that a good seal is formed around the tube.

- Again check that no part of the seal housing tube comes in contact with the moving differential components. Gently bend the tube away from moving parts if necessary.

### 4.10 Bench Testing the Air Locker

- To test the Air Locker; when 620kPa [90 PSI] shop air is applied to the seal housing tube, the Air Locker should engage.
- Check all fittings and the seal housing for air leaks.
- Rotate the differential carrier by turning the pinion flange whilst applying air pressure.

**NOTE :** An accurate way to test for air leaks is to fit a shut-off valve to an air pressure gauge (ARB part # 0770005). Once 620 KPA [90 PSI] is reached close the valve, disconnect the air hose, and watch to see if there is any drop in pressure. If so, this will indicate an air leak. (Fig.23.)

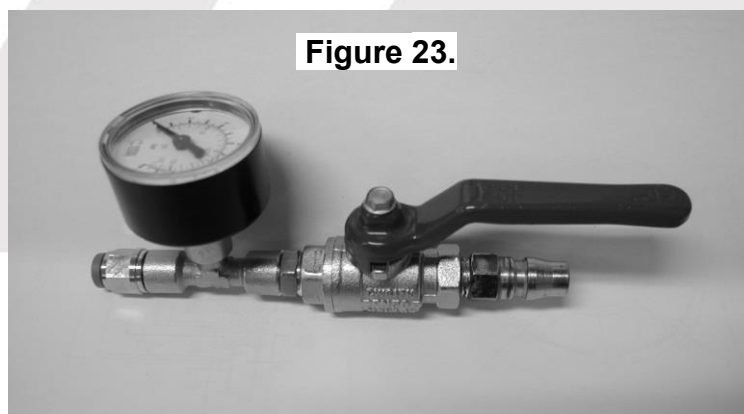

- If a leak is found to be present, spray a soap and water mixture onto the bulkhead air fitting. Bubbles should appear at any leak points.

**NOTE :** Do not spray this soapy mixture inside the differential.

- Check that leaky fittings have been adequately tightened.

## 4 Installing the Air Locker

- Disassemble, clean threads, and reapply thread sealant if leaking persists.
- If a leak is found at the seal housing, carefully remove the seal housing assembly and examine the O-rings. Be very careful with the O-rings and check for defects, damage, wear, or presence of foreign material in the O-ring grooves. Replace if necessary.

### 4.11 Reinstalling the Axles

- Reinstall the third member to the differential housing according to your vehicle service manual. Ensure that the copper tube does not contact the inside of the axle housing, or touch on the ring gear.
- Reinstall the drive shaft.
- Replace the axle seals if necessary and fit to the axles.
- Insert both axles fully into the housing, engaging splines, and then gently tap them inward.

**NOTE :** Be careful not to damage the axle shaft oil seals when installing the axle. Support the axle's entire weight where possible.

- Torque down the axle bolts to manufactures specifications.

## 5 Installing the Air System

### 5.1 Mounting the Solenoid

#### 5.1.1 Connection to an ARB Air Compressor (Fig.24.)

- Remove one of the 1/8" BSP plugs from its port in the compressor tank.
- Apply Teflon paste to the 1/8" BSP nipple on the solenoid and insert it into the port and tighten. The solenoid should be rotated into a position which does not obstruct any other ports on the compressor tank.

**NOTE :** The coil and stem of the solenoid can be removed to make installation easier.

**NOTE :** The solenoid is marked with two #1 ports. If space is tight, a second solenoid can be "daisy-chained" off the first one by removing the plug from the redundant #1 port and screwing the nipple from the second solenoid into it (Fig.24.).

**NOTE :** The solenoid exhausts compressed air through the center of the black retaining cap when the *Air Locker* is disengaged. Make sure this orifice cannot be obstructed.

- Assemble the 6mm push-in fitting into the solenoid outlet port (stamped "2") and hand tighten.

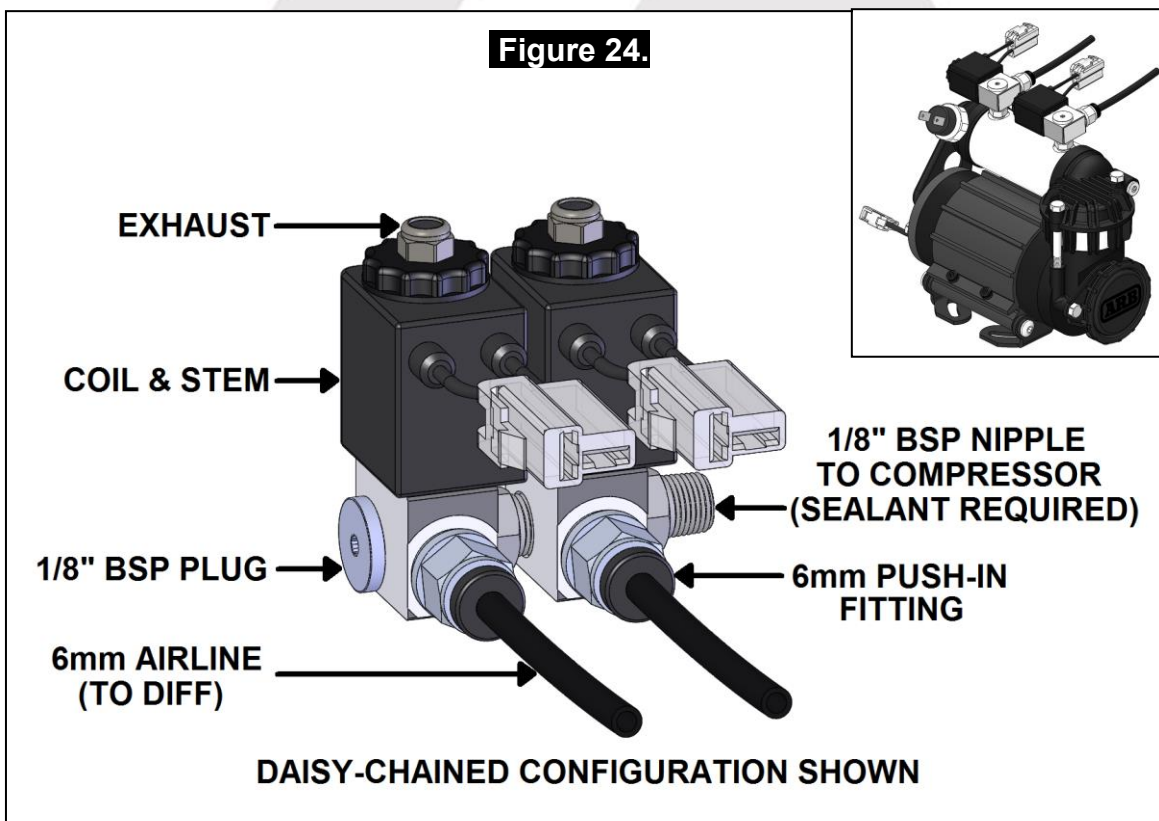

## 5 Installing the Air System

### 5.1.2 Connection to an Alternate Air Source

---

For ease of installation, quality of air supply, and a high level of dependability from your *Air Locker(s)*, ARB strongly recommends use of a genuine ARB Air Compressor, however, the *Air Locker* air system can be operated on any alternate air source that meets each of the following guidelines:

- Must supply a minimum of 85PSI [586kPa].
- The Air source should have a tank capacity that enables it to actuate the *Air Locker(s)* in one charge so that no hesitation is experienced when locking one or two differentials.

**HINT :** A good way to insure that you have the necessary capacity is to make sure you can engage, disengage, and then reengage your *Air Locker(s)* without the air source having to regenerate (e.g., without the compressor turning on to refill the tank).

- Must supply clean air, free of rust, dirt, water, or other foreign matter.
- Must match the 1/8" BSP porting of the *Air Locker* solenoid.
- Mount solenoid within close proximity of the air supply and secure it from the effects of vibration and shock.
- Connect the air supply to the 1/8" BSP inlet port of the solenoid (stamped "1" on the solenoid body) using thread sealant.

#### **IMPORTANT :**

**ARB cannot warrant your *Air Locker(s)* against damage caused as a result of using an alternate air supply. If you have any doubts as to the suitability of your air system to use in an *Air Locker* system, consult your ARB distributor.**

## 5 Installing the Air System

### 5.2 Running and Securing the Air Line

The path taken by the air line from your air source (i.e., compressor) to your *Air Locker* is unique to your vehicle and the position of your air source. Plan ahead carefully when running the air line and always follow these guidelines:

- Account for axle travel when running the line from the axle to a fixed point on the vehicle. Leave enough slack in the air line to allow for maximum suspension travel in both directions.
- Avoid leaving large lengths of air line hanging underneath the vehicle where they may get tangled on rocks, sticks, etc.

**HINT :** **Cable tying the air line to one of your flexible brake lines will account for axle travel and should help keep your line from getting snagged.**

- Run the air line all the way from the compressor to the differential before trimming either end of the line to length. This will save complications that may arise if the air line has to be removed.
- Make sure the line does not contact sharp edges or abrasive surfaces that may damage the air line over time.
- Do not run the air line around tight bends which may kink the air line and restrict or block the air flow.
- Keep the air line well away from your vehicle's exhaust components. Air lines will melt if subjected to extreme heat.
- Do not run more air line than necessary. Excess line volume created when coiling the left over hose, using unusually large diameter hose, etc., will increase drain on the compressor tank resulting in the compressor running more often than needed.
- Support the air line by tying it back with cable ties wherever possible.
- At the solenoid end of the air line, trim the line to length with a sharp knife.

**NOTE :** **To remove the air line from the push-in fitting; while holding the flange of the fitting out, push the air line into the fitting as far as possible, then press the flange inward, then pull the air line free of the fitting.**

- To attach the air line to the push-in fitting of the solenoid; insert the line firmly into the fitting, pull outward on the flange of the fitting while holding the line as far into the fitting as possible, and then gently pull outward on the air line to clamp the line in place.

## 5 Installing the Air System

### 5.3 Connection to the Bulkhead Fitting

- Trim the air line to length using a sharp knife.
- Assemble an aluminium washer onto the banjo bolt and insert through the banjo fitting. Assemble second aluminium washer and tighten into bulkhead fitting using a 14mm [9/16"] spanner. (Fig.25.)
- Apply thread sealant to the tapered thread of the compression fitting body and screw into the banjo fitting. Tighten using a 12mm spanner.
- Insert the outer compression nut and ferrule over the air line. Ferrule should be orientated as per Fig.25.

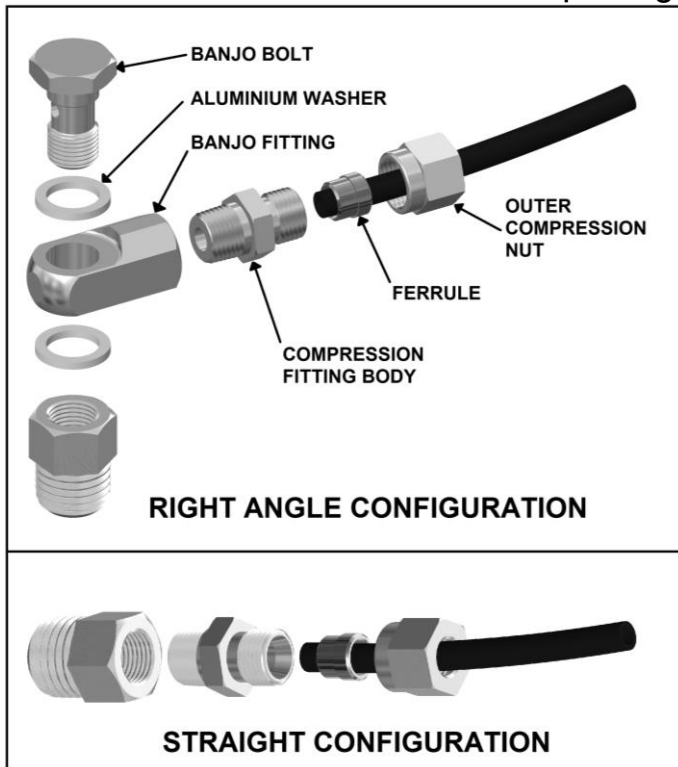

- Push the airline into the compression fitting body and screw the outer nut down onto it. Using a 12mm spanner, tighten the outer nut onto the compression fitting body.

**NOTE :** Some force is required to crush the ferrule, however the outer compression nut will tighten against a stop. Over tightening will not create a better seal.

- Secure any loose sections of tube with a cable tie.

**NOTE :** When right angle routing of the tube is not required, screw the compression fitting body straight into the bulkhead fitting body (Fig.25.).

## 6 Mounting & Connecting the Electrical System

### 6.1 Mounting the Actuator Switch(es)

*Air Locker* actuator switch(es) can be easily panel mounted inside the vehicle in a 21mm x 36.5mm [0.83" x 1.44"] rectangular cutout.

**NOTE :** Only attach the cover plate to the face of the switch once the switch has been mounted and wired correctly as the cover plates are designed to be difficult to remove.

For reasons of safety and for ease of operation, the *Air Locker* actuator switch(es) should be mounted in a location picked to best suit the operator. Make sure you have taken the following points into consideration:

- Switch(es) MUST be mounted and should never be allowed to simply dangle from the wiring loom during vehicle use.
- Switch(es) should be within easy reach of the driver. Ideally, any *Air Locker* switch should be able to be operated without physical effort or distraction to the driver.
- Switch(es) should be mounted within the line of sight of the driver so that switch position ('ON' or 'OFF') can be visually determined by the rocker position and the illumination state.
- The position of the switch(es) should best eliminate any possibility of accidental operation by the driver or one of the passengers.
- Switch cutout position(s) must be located in an area with a minimum of 50mm [2"] of clearance behind the face of the cutout.
- Switch(es) should not be mounted where they will be exposed to water (e.g., in the lower section of an inner door panel).
- ARB recommends that you apply the *Air Locker* Warning Sticker (ARB part # 210101) within close visual proximity of the switch location.

**NOTE :** If no adequate position can be found on existing dashboard panels, a surface mounted bracket (Fig.26.) may be purchased from your ARB *Air Locker* distributor to suit 1, 2, or 3 switches.

## 6 Mounting & Connecting the Electrical System



### 6.2 Wiring the Actuator System

#### 6.2.1 Connection to an ARB Air Compressor

When wiring the *Air Locker* actuator switch(es) and solenoid(s) to an ARB Air Compressor, all connections can easily be set up directly from the supplied wiring loom. (Fig.27.)

**NOTE :** 180409 model loom shown for reference only. Refer to your ARB Air Compressor Installation Guide for details on configuring your installation.

# 6 Mounting & Connecting the Electrical System

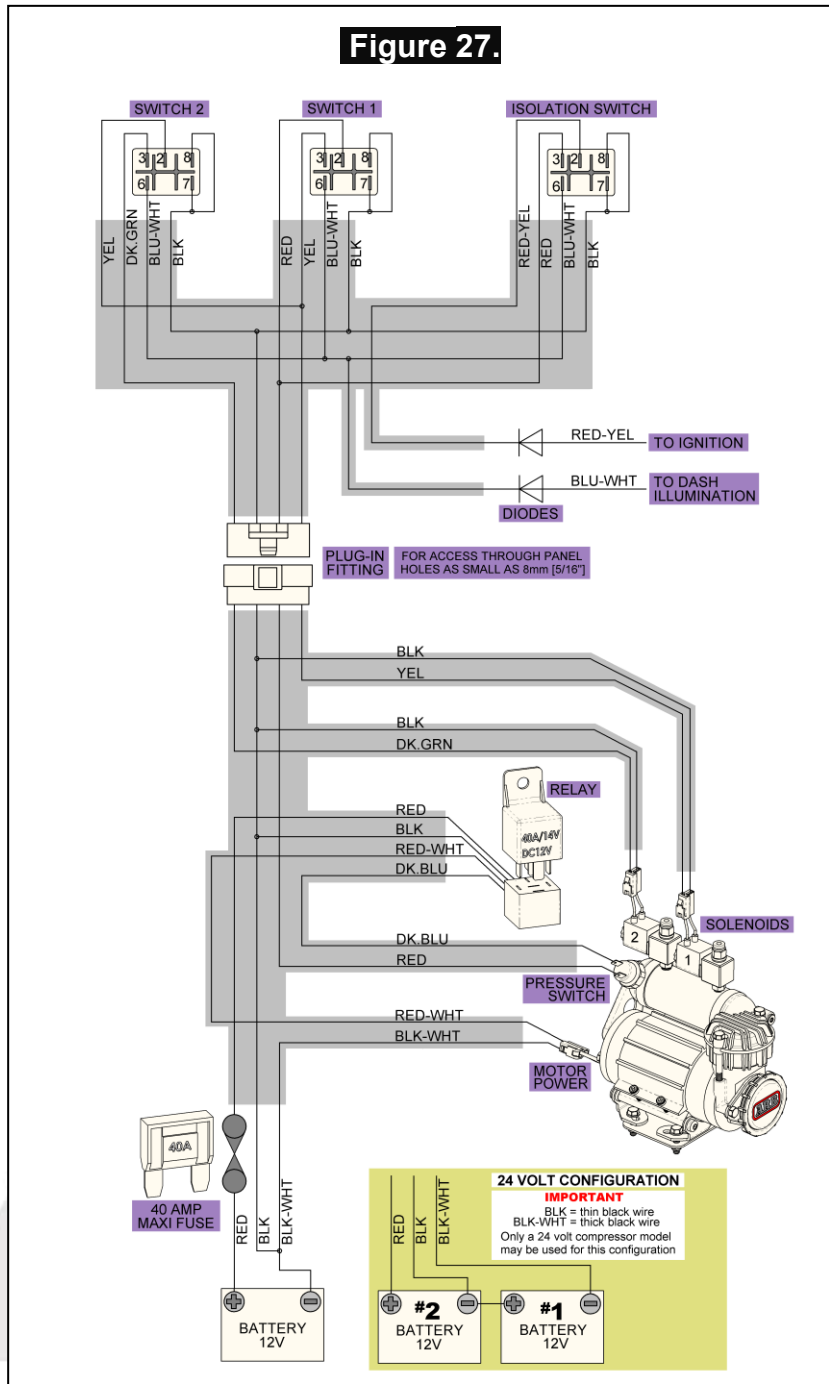

## 6 Mounting & Connecting the Electrical System

### 6.2.2 Connection to an Alternate Air Source

When connecting the actuation switch to an alternate air source, the switch(es) should be wired according to Fig.29. and 30., depending on whether one or two *Air Lockers* will be installed in the vehicle.

#### 6.2.2.1 Single Air Locker System

- If only one *Air Locker* is to be installed in the system, the switch and solenoid should be wired according to Fig.29. regardless of whether the *Air Locker* has been installed in the front or rear axle of the vehicle.
- Attach the appropriate switch cover (i.e., 'FRONT' or 'REAR') to the switch.

**NOTE :** Refer to Fig.28. for the correct switch terminal identification and switch orientation.

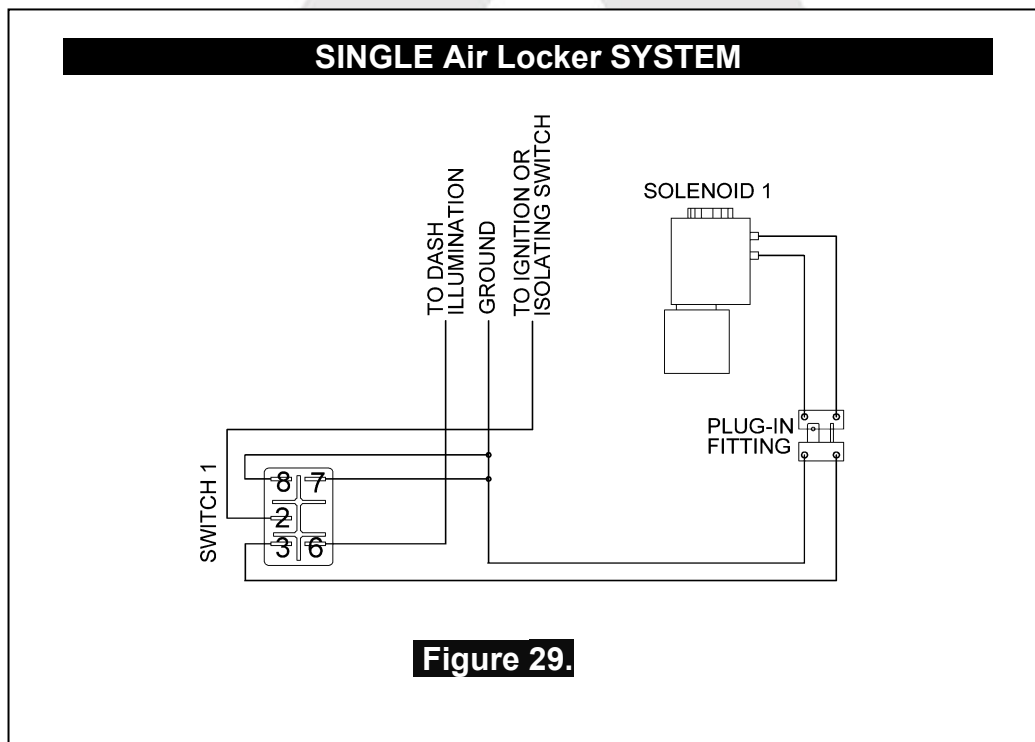

## 6 Mounting & Connecting the Electrical System

### 6.2.2.2 Dual Air Locker System

- If two *Air Lockers* are to be installed in the system, ARB recommends that the switches and solenoids be wired according to Fig.30. For safety reasons, this configuration allows SOLENOID 2 to be actuated only if SOLENOID 1 is already on.
- Attach the “REAR AIR LOCKER” switch cover to SWITCH 1, and the “FRONT AIR LOCKER” switch cover to SWITCH 2.

**NOTE :** Refer to Fig. 28. for the correct switch terminal identification and switch orientation.

- Configure SOLENOID 1 as the air line leading to the rear axle *Air Locker*, and SOLENOID 2 as the air line leading to the front axle *Air Locker*.

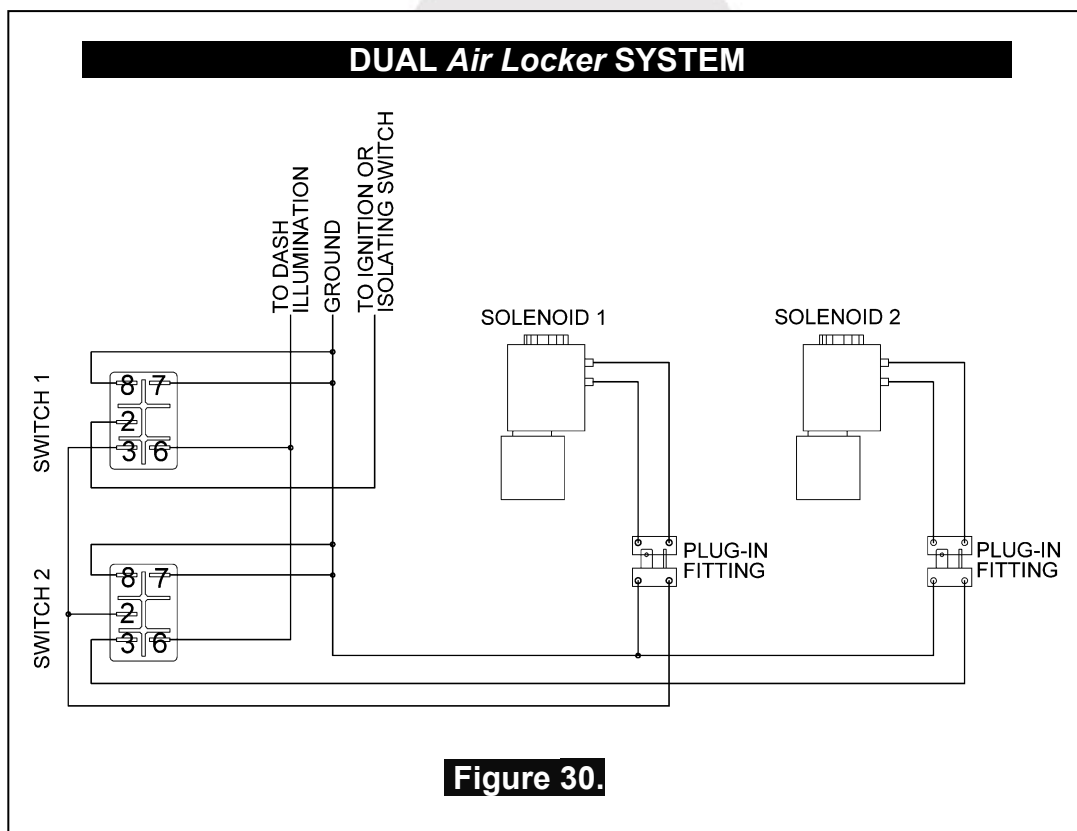

## 7 Testing & Final Assembly

### 7.1 Leak Testing

- With the vehicle parked and the engine off, turn the compressor on and wait until the air system is fully charged.

**NOTE :** With the *Air Locker(s)* disengaged, the air source (i.e., compressor) should not have to recharge over time. Intermittent recharging without *Air Locker* use usually indicates a leak at the solenoid fittings or at the compressor tank O-ring seal.

- Actuate the *Air Locker(s)*.
- The compressor should not come on again for a period of at least 15min. Air system recharging within that time period would indicate that a leak is present in the system.

**NOTE :** If an alternate air source (e.g., an air cylinder or a belt driven air pump) is used instead of a compressor, the air system will have to be leak tested with a pressure gauge and a shut-off valve in series before the solenoid input.

- If a leak is found to be present, spray a soap and water mixture onto all air fittings in the system while the compressor is fully charged. Bubbles should appear at any leak points.
- Check that leaky fittings have been adequately tightened.
- Disassemble, clean threads, and reapply thread sealant if leaking persists.

## 7 Testing & Final Assembly

### 7.2 Testing the Air Locker Actuation

To test that your air system, electrical system, and your *Air Locker* differential is functioning correctly:

- Support the vehicle such that the wheels are free to rotate (e.g., on axle stands, a chassis hoist, etc.)
- Leave the parking brake off, the transmission in neutral, and the *Air Locker* switch 'OFF'.
- Turn the ignition to the 'ON' position (leaving the motor off). The large illuminating symbol on the *Air Locker* switch cover should be 'OFF'.
- Turn the compressor (or alternate air source) on to charge the air supply up to its maximum pressure.
- Rotate one wheel by hand.
- The wheel should rotate freely and the opposite wheel should be turning in the opposite direction without any resistance or mechanical noise from within the differential.
- Turn the *Air Locker* switch to the 'ON' position. The illuminated symbol on the switch cover should light up.
- Rotate the same wheel again.
- Both wheels should rotate together.
- Turn the switch off again.
- Rotate the same wheel.
- The wheels should again rotate in opposite directions.

## 7 Testing & Final Assembly

### 7.3 Re-Sealing & Filling the Differential

**NOTE :** Consult the *ARB Air Locker Operating & Service Manual* for recommendations on differential lubricant specifications.

- Refill the differential until level with the filler hole.
- Rotate the differential center 2 full turns.
- Check the oil level and add oil if necessary.
- Replace filler plug (apply thread sealant to filler plug before inserting if it is a threaded type plug).
- Wipe differential housing clean of any oil or grease which may collect dirt or other abrasive particles.



## 7 Testing & Final Assembly

### 7.4 Disable Factory Diff Lock Switch & Actuator Plug Modification

#### **IMPORTANT:**

This step is only applied to replace the OE differential locker with an Air Locker to avoid dashboard warning.

#### 7.4.1 Disable Factory Diff Lock Switch

- Use a trim removal tool lever up each side of the dash panel that surrounds the air vent panel as shown. (Fig.31.)



- Gently pull that same dash panel, from both sides, towards the rear of the car to remove it. (Fig.32.)



- Unplug the hazard switch connect from the rear of the dash panel to remove it completely. (Fig.33.)

## 7 Testing & Final Assembly

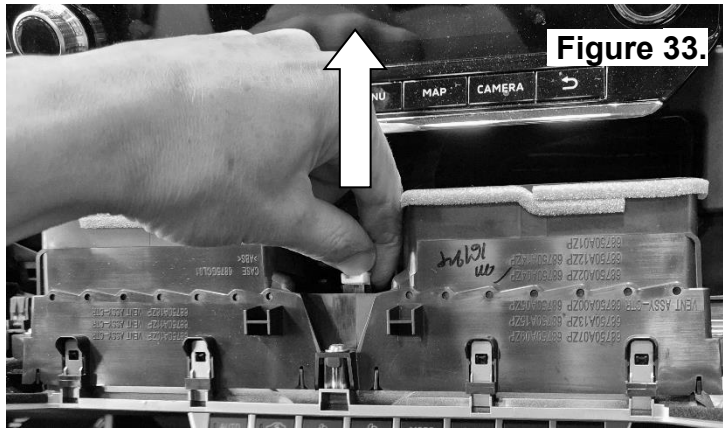

- Undo the screw as shown, then remove the panel by pulling it towards the rear of the vehicle. (Fig.34.)



- Partly remove the equivalent, but longer piece on the opposite side. It only needs to be pulled back to access one screw in the next step. (Fig.35.)



## 7 Testing & Final Assembly

- Undo the four screws that secure the climate control module. Then gently pull it toward the rear of the car. (Fig.36.)



- Unplug the connector at the back of the climate control module as shown. (Fig.37.)

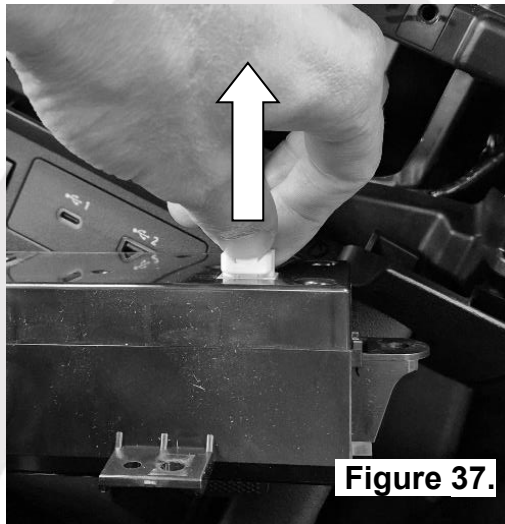

- Remove the narrow trim panel above the diff lock switch panel. Pull it towards the rear of the vehicle as shown. (Fig.38.)

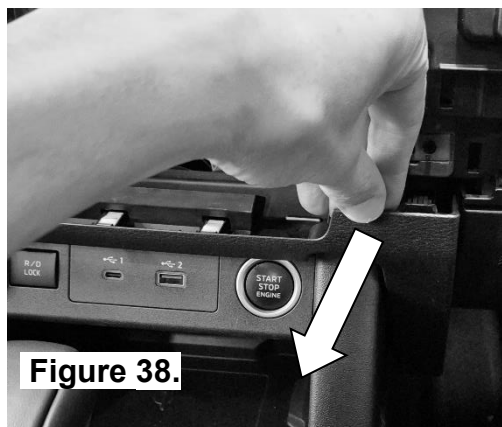

## 7 Testing & Final Assembly

- Remove the cover panels on both sides of the diff lock switch panel to reveal the screws that hold it in place. (Fig.39.)

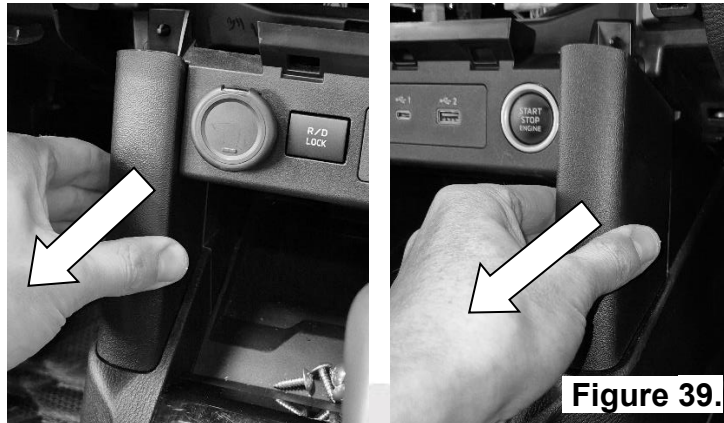

- Undo the two screws that secure the diff lock switch panel. (Fig.40.)



- Pull the diff lock switch panel from the top edge as shown, to get access to the diff lock switch connector. (Fig.41.)

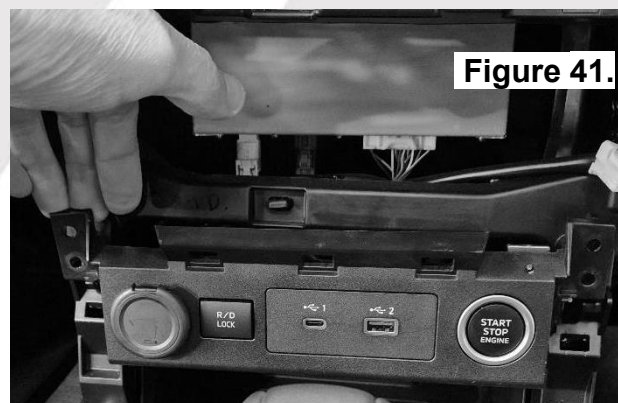

- Unplug the diff lock switch connector as shown, the diff lock switch has now been disabled. (Fig.42.)

## 7 Testing & Final Assembly

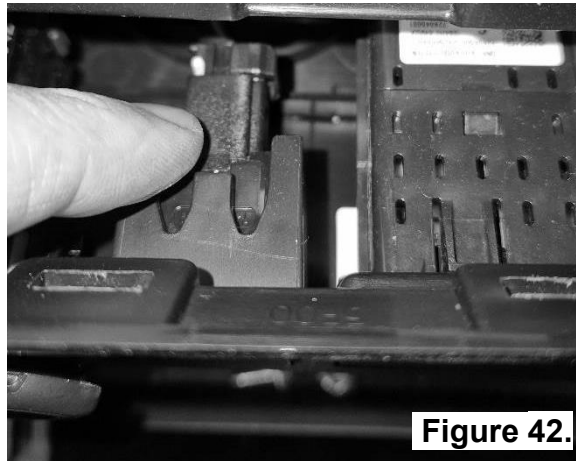

Figure 42.

- Re-assemble all of the components (except the diff lock switch connector) in the reverse order.

**NOTE :** Pay particular attention to re plugging in the connectors for climate control module, and the hazard light button.

### 7.4.2 Diff Lock Actuator Plug Modification

---

- Unplug the diff lock actuator plug as shown. (Fig.43.)

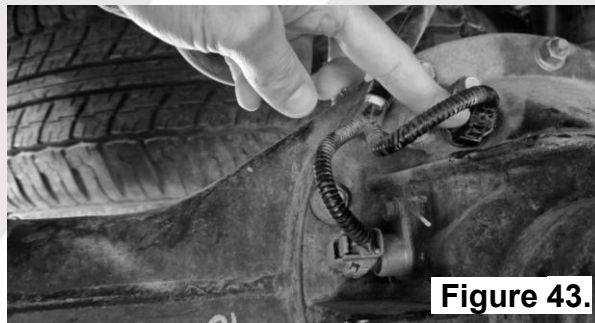

Figure 43.

- Cut the plug off the wiring harness close to the plug. (Fig.44.)

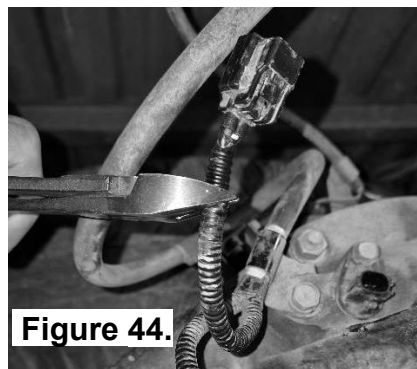
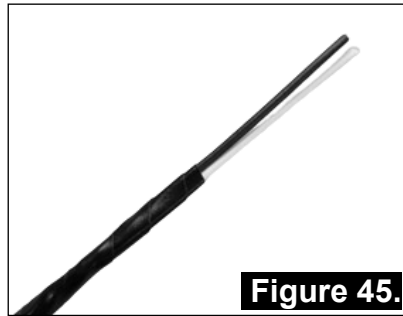

Figure 44.

## 7 Testing & Final Assembly

- Peel back about 4cm of tape. (Fig.45.)



- Cut one wire shorter and strip 5mm of insulation from the end of each wire. (Fig.46.)

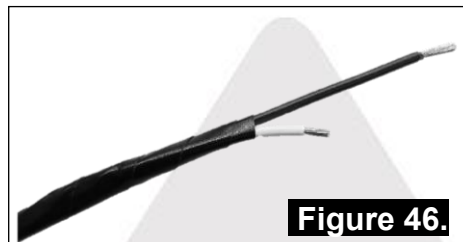

- Solder a 1000 Ohm, 0.25W resistor between the two wires as shown. (Fig.47.)

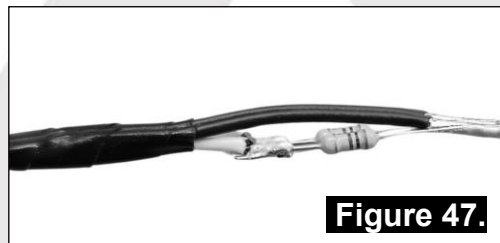

- Cover in a 5cm length of glue heat shrink to protect and seal the solder joint. Ensure the heat shrink is long to extend over both ends of the joint. (Fig.48.)



- Cable tie this end of the harness securely to the other part of the wiring harness.

## 7 Testing & Final Assembly

### 7.5 Post-Installation Check List

Now that the *Air Locker* installation has been completed, ARB recommends that you take the time to complete the following check list just to insure that you haven't missed any of the vital steps.

- The air system has been leak tested.
- Thread locking compound was used on the ring gear bolts.
- All torque settings comply with the vehicle manufacturer's specs and were set with an accurate torque wrench.
- Differential fluid complies with ARB recommendations and has been filled to the correct level.
- All air lines and wiring have been securely cable tied to resist snagging.
- Switch(es) have been securely mounted within operator reach, yet well away from danger of accidental engagement.
- Switch(es) function properly and illuminate to indicate that *Air Locker(s)* are engaged.
- All operators who are to use the *Air Locker* have read, and fully understand the *ARB Air Locker Operating & Service Manual*.
- The *Air Locker* Warning Sticker has been located within close proximity of the actuator switch(es).

**INSTALLATION PERFORMED BY:** \_\_\_\_\_

**DATE OF INSTALLATION:** \_\_\_\_\_

**ODOMETER READING:** \_\_\_\_\_

**ARB AIR LOCKER SERIAL No:** \_\_\_\_\_





## 8 Parts List

**RD275**

MITSUBISHI TRITON, REAR, 31 SPLINE

### 8.1 Exploded Assembly Diagram (See itemized parts list overleaf)

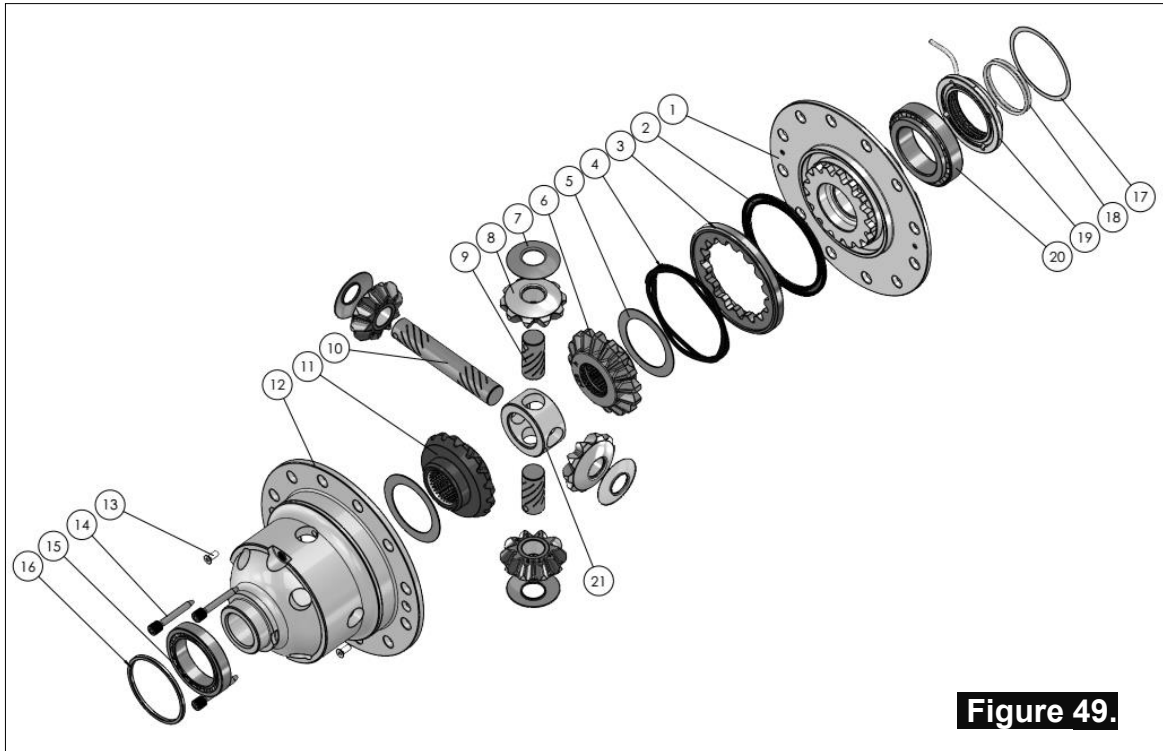

### 8.2 Specifications

Axle Spline	31 tooth, Ø33.6mm [1.32"]
Ratio Supported	All
Ring Gear ID	144.97mm [5.71"]
Ring Gear OD	230mm [9.06"]
Ring Gear Bolts	12 bolts on Ø175mm [6.89"]
Ring Gear Bolt Size	M12
Ring Gear Torque	152Nm [112 ft-lb]
Backlash	0.13-0.18mm [0.005-0.007"]
Bearing Cap Torque	99Nm [73 ft-lb]

## 8 Parts List

### 8.3 Itemized Parts List

(See exploded diagram Fig.49.)

ITEM #	QTY	DESCRIPTION	PART #	NOTES
01	1	FLANGE CAP KIT	027363SP	
02	1	BONDED SEAL	160702SP	
03	1	CLUTCH GEAR & WAVESPRING KIT	050906SP	
04	1	WAVESPRING	150706SP	
05	2	SIDE GEAR THRUST WASHER	SEE NOTE	1
06	1	SPLINED SIDE GEAR	SEE NOTE	2
07	4	PINION THRUST WASHER	SEE NOTE	1
08	4	PINION GEAR	SEE NOTE	2
09	2	SHORT CROSS SHAFT	060403SP	
10	1	LONG CROSS SHAFT	060204SP	
11	1	SIDE GEAR	SEE NOTE	2
12	1	DIFFERENTIAL CASE	013064SP	
13	1	COUNTERSUNK SCREW (PK OF 2)	200213SP	
14	1	RETAINING PIN SET (PK OF 4)	120601SP	
15	-	TAPERED ROLLER BEARING	NOT SUPPLIED	4
16	1	SHIM KIT	SHK013	
17	1	SHIM KIT	SHK008	
18	1	SEAL HOUSING O-RINGS (PK OF 2)	160207-2	3
19	1	SEAL HOUSING KIT	081824SP	
20	-	TAPERED ROLLER BEARING	NOT SUPPLIED	
21	1	SPIDER BLOCK	070201SP	
*	1	BULKHEAD SEAT	110403SP	
*	1	WASHER FLAT M6X25X2.8	4584379	
*	1	BULKHEAD FITTING (BANJO TYPE)	170114	
*	1	AIR LINE (6mm DIA X 6m LONG)	170314SP	
*	1	SOLENOID VALVE (12V)	180103	
*	1	SWITCH RR LOCKER	180224SP	
*	1	CABLE TIE (PK OF 25)	180305	
*	1	OPERATING & SERVICE MANUAL	210200	
*	1	INSTALLATION GUIDE	2102275	
*	1	DIFF INSTALLATON RECORD	215762A	

\* *Not illustrated in exploded view*

### NOTES

- 1 Available only as complete thrust washer kit #730H01
- 2 Available only as complete 6 gear set # 728H211
- 3 For replacement O-rings use only BS136 Viton 75.
- 4 For Triton equipped with a factory locker, the bearing from diff case side is difficult to be removed without damaging it. Source the bearing (Part no. NSK HR32910J or Mitsubishi part no. 38440A010P) through bearing wholesaler or Mitsubishi as a spare bearing before attempting removal.

Part No. 2102275  
Revision 7/11/2025  
Copyright © 2015 by ARB Corporation Limited

