



## BRUSHLESS TWIN PORTABLE

# *OPERATION GUIDE*



**CKBLTP12**

Part No. 2102BLTP12  
Revision Date 24/07/2025  
Copyright © 2025 by ARB Corporation Limited



## EU DECLARATION OF CONFORMITY

1. This declaration relates to this product:

1.1 Product name ARB Brushless Air Compressor  
1.2 Model No. CKBLA12, CKBLP12, CKBLTA12, CKBLTP12

2. Manufacturer

2.1 Company ARB Corporation Limited  
2.2 Address 42-44 Garden St, Kilsyth, Victoria, Australia

3. This declaration of conformity is issued under the sole responsibility of the manufacturer.

4. The object of the declaration described above is in conformity with the relevant Union harmonization legislation:

|                |                                  |
|----------------|----------------------------------|
| 4.1 Directives | 4.2 Applied Harmonized Standards |
| 2014/30/EU     | <b>EN 55014-1:2021</b>           |
|                | <b>EN 55014-2:2021</b>           |

5. The technical file for this product is kept at the manufacturer's address listed above.

6. Signed for and on behalf of: ARB Corporation Ltd

6.1 Signature

6.2 Name Lachlan McCann  
6.3 Position Chief Executive Officer  
6.4 Place and date of issue Kilsyth, December 2024

---

## ARB 4x4 ACCESSORIES

Corporate Head Office

42-44 Garden St  
Kilsyth, Victoria  
AUSTRALIA  
3137

Tel: +61 (3) 9761 6622

Australian enquiries  
North and South American enquiries  
Other international enquiries

sales@arb.com.au  
sales@arbusa.com  
exports@arb.com.au

---

**www.arb.com.au**

# Table of Contents

|          |   |    |
|----------|---|----|
| <b>1</b> | <b>Introduction</b>                                 |    |
| 1.1      | Features of the CKBLTP12 Portable Compressor.....   | 4  |
| 1.2      | What Is Included .....                              | 5  |
| <b>2</b> | <b>Safe Air Compressor Operation</b>                |    |
| 2.1      | Safety Precautions .....                            | 6  |
| 2.1.1    | Electrical Safety .....                             | 6  |
| 2.1.2    | Compressed Air Safety.....                          | 6  |
| 2.1.3    | Pressure Vessel Safety.....                         | 7  |
| 2.1.4    | High Temperature Safety.....                        | 7  |
| 2.2      | Connecting for Use.....                             | 8  |
| 2.3      | Tyre Filling.....                                   | 10 |
| 2.4      | Air Powered Tools .....                             | 11 |
| 2.5      | Keeping the Carry Case Organised .....              | 12 |
| 2.6      | Understanding the Built-In Protection Devices ..... | 13 |
| 2.6.1    | Polarity Correction Harness.....                    | 13 |
| 2.6.2    | Over Pressure Safety Valve .....                    | 13 |
| 2.6.3    | Electronic Thermal Protection .....                 | 13 |
| 2.6.4    | Electronic Overload Protection .....                | 14 |
| 2.6.5    | System Fault Codes.....                             | 15 |
| <b>3</b> | <b>Service and Maintenance</b>                      |    |
| 3.1      | Air Filter Service .....                            | 16 |
| 3.2      | Wiring Harness Replacement .....                    | 17 |
| 3.3      | Draining Moisture from the Air Tank .....           | 17 |
| <b>4</b> | <b>Parts List</b>                                   |    |

## **IMPORTANT:**

**To get the safest and most effective service from this portable air compressor, please read this guide in its entirety before attempting to use the compressor.**

### **1.1 Features of the CKBLTP12 Portable Compressor**

The ARB CKBLTP12 Brushless Portable Air Compressor is a compact yet high performance compressed air source that is intended for rapid inflation of large tyres and operation of most air powered tools rated up to 97 LPM [3.4 CFM] @ 600 kPa [90 psi].

The ARB CKBLTP12 is a world class recreational product designed and built to commercial / industrial standards boasting the following features:

- Ultra-compact twin brushless motor with dual cylinder design makes this the highest flowing portable compressor of its size on the market at 260 LPM [9.18 CFM].
- Integrated aluminium air tank and pressure switch regulates pressure between 930 kPa [135 PSI] and 1030 kPa [150 psi] suited to most air powered tools.
- Mounted in a waterproof carry case constructed from a durable impact resistant polymer. The carry case has convenient compartments for storing the air hose and other compressor accessories.
- Dual ducted IP55 sealed brushed DC cooling fans and anodised aluminium motor bodies effectively dissipate heat from the motors, heads and electrics/electronics allowing for a 90% duty cycle (under room temperature conditions).
- Engineered, built and individually dyno-tested in Australia from local and imported components.
- Fully serviceable and all replacement parts available.
- Constructed primarily of light weight, high strength engineering grade materials, including military and aerospace standard components.
- Hard-anodised cylinder bores and PTFE (Teflon) impregnated carbon fiber piston seals for reduced friction and maximum trouble free life.
- Built with sealed components for moisture and dust resistance.
- Motors are 100% ball bearing equipped, and feature brushless drive technology meaning there are no wearing components in the motors.
- Compressor pistons are equipped with a needle roller bearing rated for high shock loads over a long service life.
- High density and high flow washable sintered bronze air filter element.
- Electronically protected against high temperature and electrical overload situations.
- Pressure switch equipped electrical system prevents run-on when not filling, or any damage to compressor or hoses as a result of the pressure generated from a kinked air line.

# 1 Introduction

- Illuminated isolating switch is easy to see at night, and protects the user from hazardous sparking when connecting the alligator clips to the battery terminals.
- Over-pressure safety valve equipped as a back-up protection from either pressure switch failure, thermal over pressure generated in a hot vehicle (i.e., no need to drain pressure when finished use.), or accidental connection to an external high pressure source.
- Any fault conditions are visually and audibly communicated to the user.
- Hose couplings are specially designed corrosion resistant, one-handed (push-lock) quick connect type to suit US industrial standard air fittings (Ref: compatible types Section **Error! Reference source not found.**).
- Quality Japanese air hose is easy to un-roll/re-roll without knotting and kinking.

## 1.2 What Is Included

Below is a detailed list of items included with this kit:

- Fully assembled and performance tested air compressor and air tank mounted into a water proof carry case with an air travel pressure equalization valve.
- Canvas compartment for storing air hose and compressor accessories.
- OEM quality illuminated compressor isolating switch.
- OEM quality pressure control switch.
- High quality wiring harness with automotive grade alligator clamp type battery contacts and electronic battery polarity correction.
- Two splash resistant air filters with washable high-flow sintered bronze filter cartridges.
- 7 meter [23 ft] long high quality abrasion and heat resistant air hose with male to female couplings.
- Air blow gun with US industrial standard male air fitting.
- Inflation accessories kit including high-flow tyre filler attachment (US industrial standard) with integral stop-valve, a Schrader valve to US industrial standard adaptor, and extra nozzle attachments for inflating items such as sports balls, air mattresses, etc.

## 2 Safe Air Compressor Operation

### 2.1 Safety Precautions

Please carefully read and always abide by each of the following points when using a portable air compressor.

**HINT:** Place a ✓ mark inside each of the  symbols to ensure you have read and understood all of the safety precautions.



#### 2.1.1 Electrical Safety

- Never make connections to the battery with the compressor isolating switch turned 'ON' as the resulting sparking at the battery terminals could pose a fire hazard.
- Do not leave the compressor unattended while connected to power.

#### 2.1.2 Compressed Air Safety



- Wear suitable protective equipment (e.g., glasses, face shields, etc.) to control the risk of injury due to projectile particles.
- Never point the hose at anyone and always see that bystanders are out of the line of air flow.
- Never attempt to stop or slow the flow of compressed air using direct exposure to skin.

**NOTE:** Normal textile clothing does not protect the skin against the risk of air embolism posed by exposure to compressed air.

**NOTE:** An air embolism is a serious condition of the blood stream which may result in severe injury or death.

- For the same reason as above, never use compressed air to clean clothing, hair or body.
- Disconnecting hoses or other accessories from a compressed air system can result in projectiles. To avoid projectiles either hold the item being disconnected securely or switch off the compressor and evacuate all compressed air from the system.
- If using compressed air accessories (e.g., extension or replacement hoses, or pneumatic devices like air tools) other than genuine ARB, avoid the danger of spontaneous disconnection by using only products with hose fittings that conform to one of the international standards listed in the specifications (ref: Section **Error! Reference source not found.**).
- If using extension or replacement hoses other than genuine ARB hoses, use only sound strong hose with secure couplings and connections having a high temperature rating and a maximum pressure rating of over 1380 kPa [200 PSI].

## 2 Safe Air Compressor Operation

- Air hoses should be securely held to prevent whipping.
- Compressed air contains contaminants which makes it unsuitable for use in air-supplied respiratory protective devices such as spray painting masks. Only use compressed air with such devices when appropriately filtered through approved filtration equipment.
- When inflating items with a small air capacity, ensure that you can switch the compressor off quickly. The high air flow rate of the brushless air compressor may overinflate your item and lead to rupture.



### 2.1.3 Pressure Vessel Safety

---

- The ARB CKBLTP12 contains a mechanical pressure relief valve that will bleed off system pressure above 1172 kPa [170 psi].
- The air tank contains compressed air and could result in an explosion if punctured. Avoid impacting the air tank with anything that could cause a puncture.
- If the air tank is damaged in any way it should be replaced immediately.



### 2.1.4 High Temperature Safety

---

- The compressor, hoses and fittings may become hot after an extended period of use. Caution must be exercised to avoid handling the hot surfaces.
- Do not operate the ARB CKBLTP12 with the heat shield removed.
- After use leave the clamps attached to the battery until the compressor cools down. The fans will shut off automatically when cool.

## 2 Safe Air Compressor Operation

### 2.2 Connecting for Use

- Position the compressor on a sturdy flat surface before opening the box.
- Unlock and open the box using the two latches.
- Make sure that the switch is in the 'OFF' position by pressing down on the top of the switch rocker.



- Uncoil the polarity correcting power lead and connect one of the two alligator clamps (BLUE handle) directly to the positive (+) terminal of the vehicle's 12 volt battery.
- Connect the remaining alligator clamp (BLUE handle) directly to the negative (-) terminal of the vehicle's 12 volt battery.

**NOTE:** Both of the alligator clamps are BLUE. There is no positive or negative (RED/BLACK) connection distinction as CKBLTP12 features electronic polarity correction to protect the compressor motors from catastrophic damage due to incorrect polarity connection.

**NOTE:** The switch should now be illuminated and the compressor will audibly confirm to you that the compressor has been connected to power. The compressor will not start until the switch rocker is pressed on the bottom.

- Attach the air hose to the compressor by inserting the male end of the hose into the hose coupling on the compressor and simply pressing inward until the coupling sleeve clicks forward. The sleeve of the coupling does not need to be pulled back by hand at all.
- Attach the compressed air accessory to the opposite end of the hose in the same way.
- Assure that the bottom of the box area is clear of foreign objects that might block the cooling air circulation or be damaged by the heat of the hot air exhaust points.

## 2 Safe Air Compressor Operation

- Press the bottom of the rocker switch down to start the compressor and pressurise the air tank and hose.
- The compressor will automatically stop when the pressure in the system reaches the pre-set pressure switch 'OFF pressure' of 1030 kPa [150 psi].

**NOTE:** Once compressed air has been expelled through the attached device (e.g., tyre filler, air tool, etc.) and the pressure in the system reduces past the pre-set pressure switch 'ON pressure' of 930 kPa [135 psi] then the compressor will automatically start running again.

### IMPORTANT:

When accessories such as the hose are connected to the compressor they will contain compressed air. As such, care must be taken when they are disconnected from the compressor to avoid projectiles.

- To disconnect the air hose from the compressor, hold the hose coupling grip between your thumb and forefinger as shown, then press the hose coupling down. Make sure to securely hold the hose grip with the remaining fingers on your hand to control the hose release when pressurised.



## 2 Safe Air Compressor Operation

### 2.3 Tyre Filling

- With the compressor connected and switched on as described in Section 2.2, connect the ARB tyre filler (supplied) to the air hose coupling by inserting it into the coupling and simply pressing inward until the coupling sleeve clicks forward. The sleeve of the coupling does not need to be pulled back by hand at all.

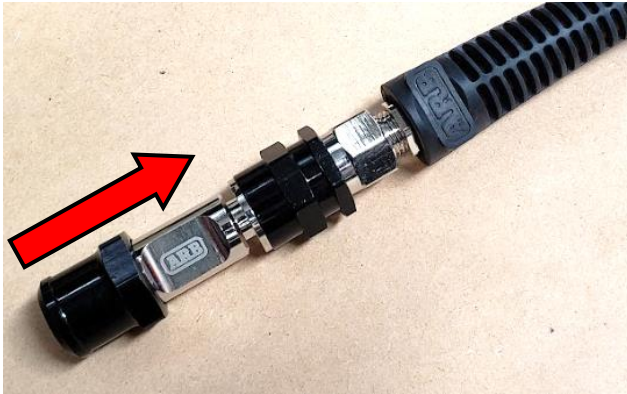

- NOTE:** ARB's tyre filler attachment is equipped with a stop valve. Air will not pass through the tyre filler attachment until it is connected to a tyre valve.
- NOTE:** To get maximum performance out of the compressor and to avoid depleting your vehicle's battery it is highly recommended to leave the vehicle running.
- Attach the ARB tyre filler to any standard tyre valve by pushing the filler onto the tyre valve until a good seal is made.
- NOTE:** Once air has passed through the filler and the pressure in the air tank reduces the compressor should automatically start.
- NOTE:** To reduce wear on the motors and your vehicle's charging system, one motor on the CKBLTP12 has an intentional staggered start. The secondary motor will wait for the primary motor to get up to speed before starting.
- To stop filling and remove the filler from the valve, push the silver filler body toward the tyre then pull back on the black filler collar. This will release the filler's grip on the valve.
- NOTE:** Periodically disconnect the filler and check the tyre pressure with an automotive tyre pressure gauge.

### **IMPORTANT:**

**Do not fill your tyres over the manufacturer's specified maximum pressure rating.**

- To protect the tyre valve, always re-fit the valve cap.

## 2 Safe Air Compressor Operation

### 2.4 Air Powered Tools

In addition to tyre inflation the ARB CKBLTP12 is suitable for operating most air powered tools, some of which are shown below.

- With the compressor connected and switched on as described in Section 2.2, connect the air tool to the air hose coupling by inserting it into the coupling and simply pressing inward until the coupling sleeve clicks forward. The sleeve of the coupling does not need to be pulled back by hand at all.
- The ARB CKBLTP12 will continuously run air tools which require up to 97 LPM [3.4 CFM] @ 600 kPa [90 psi]. For maximum power output from your air tool allow the compressor to fill the air tank to maximum pressure before operating and in between uses



## 2 Safe Air Compressor Operation

### 2.5 Keeping the Carry Case Organised

The ARB CKBLTP12 packs a lot of gear into a purpose built carry case. The compressor carry case has been designed with designated storage compartments for the included accessories to help keep things organised.

The picture below shows the suggested layout for organizing the carry case in the most effective way.

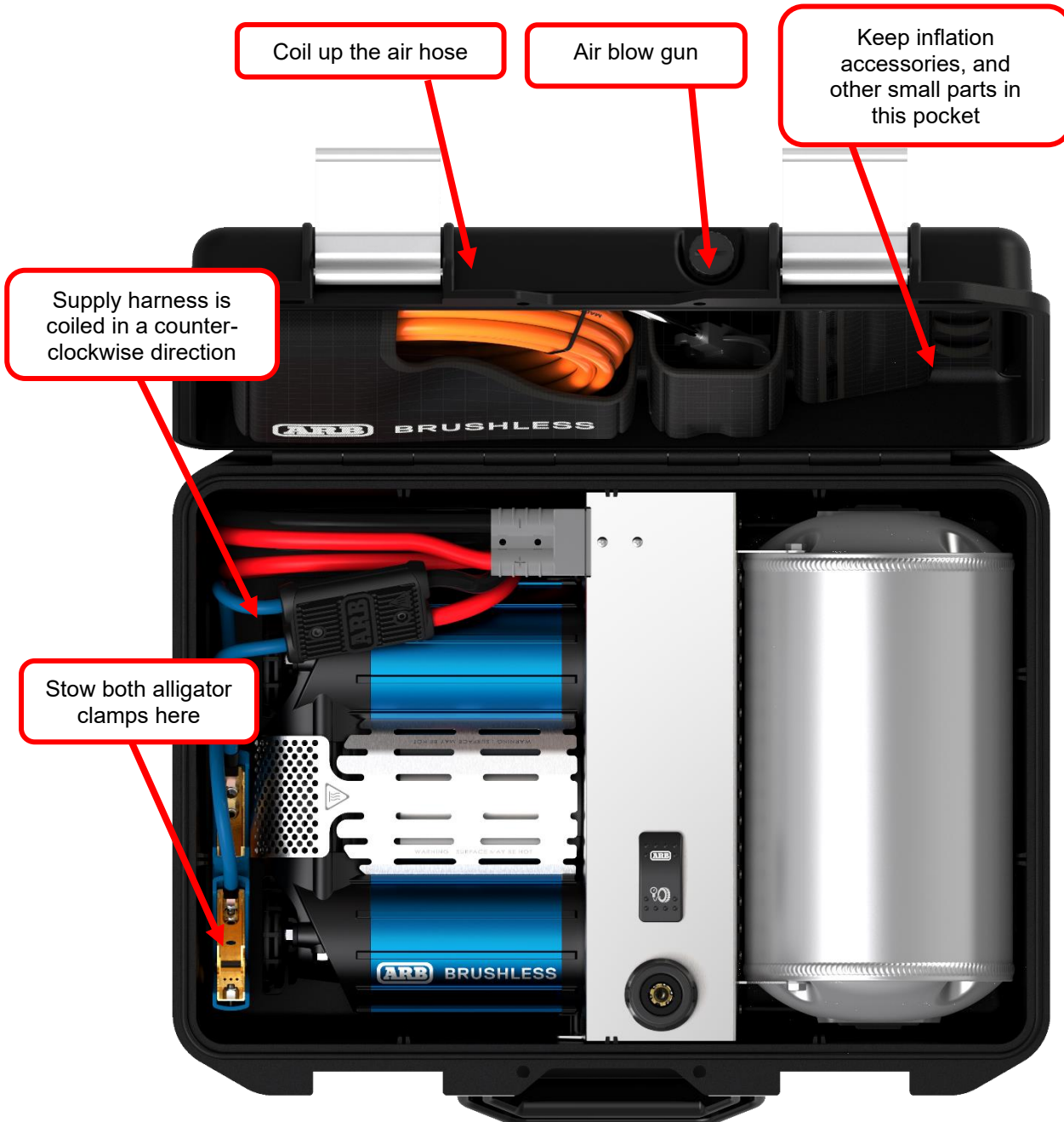

## 2 Safe Air Compressor Operation

### 2.6 Understanding the Built-In Protection Devices

An air compressor can be a complex tool, dependent upon maintaining safe levels of temperature, supply current, and air pressures. This compressor has been equipped with active protection devices in the interests of personal safety and to protect the unit from unnecessary internal damage.

**NOTE:** Never disable or modify any of the compressor's built-in protection devices.

#### 2.6.1 Polarity Correction Harness

This compressor is supplied with a power harness that is equipped with an electronic module capable of correcting for incorrect battery polarity regardless of which battery terminals the alligator clips are connected to. This module also serves as the fuseless circuit overload protector, and it will disconnect the harness power if the harness becomes overloaded (i.e., if the harness were to become shorted from being pinched in a door). To reset the overload protection simply disconnect a battery terminal and then reconnect it.

#### 2.6.2 Over Pressure Safety Valve

This compressor is equipped with a pressure operated electric switch which has been factory set to turn off the compressor at a safe level of pressure, and then turn it back on again once the pressure has been exhausted down to a lower level. Should this switch fail for any reason the compressor is capable of producing pressure well beyond its safe shut off limit.

A compressor which has reached its safe pressure maximum that has been left in direct sun or inside a hot vehicle may build up additional pressure past the safe working level.

Connecting your compressor up to any air system which might already contain a residual pressure that is higher than the compressor's safe pressure limit may raise the internal pressure of the compressor past the safe pressure limit.

This compressor is equipped with a mechanical over pressure safety valve which has been factory set to bleed off to the atmosphere any excessive pressure build up (i.e., from any of the situations above) before it can pose any personal danger or cause damage to compressor components.

#### 2.6.3 Electronic Thermal Protection

The process of compressing air is a natural generator of heat. This heat generation is increased accordingly by compressing air at a high flow rate or by increasing the pressure level of the air flow (i.e., filling at a high pressure).

The large brushless electronic speed controllers inside the CKBLTP12 compressor are also a source of heat which increases with the amount of work being done by them.

The CKBLTP12 compressor is equipped with dual brushless cooling fans pushing hot air out through a connected system of heat ducts, and in this way it has been designed to naturally disperse this heat into the air around it. However, obstructed ventilation or

## 2 Safe Air Compressor Operation

increased ambient temperature outside will have a negative effect on the cooling air, and therefore effect the rate at which this heat can be dispersed.

If excessive levels of heat are allowed to build up inside the compressor, the unit may be put at risk of internal damage. For this reason this CKBLTP12 is electronically thermally protected. When excessive levels of heat are detected in any of multiple zones within the compressor, it will attempt to reduce heat generation by intentionally slowing down the compressor's run speed. If the lowest effective run speed still cannot mitigate high temperature related damage then it will simply turn the compressor off until the temperature returns to a safe temperature level. This off-time may last anywhere from just a few minutes up to half an hour depending on conditions around the compressor. The cooling fans will continue to run during this off-time. Please keep the compressor connected to the battery to keep the fans running.

Any motor that has stopped due to a fault condition will show a series of blinks/flushes of the isolation switch, and also play an audible series of beeps.

Once stopped the motor will remain in this blink/flash/beep state until the isolation switch is cycled OFF/ON where it will again attempt to run at full speed.

The number of blinks/flushes/beeps pertains to a code, the meaning of which can be identified in Section 2.6.5 (System Fault Codes).

### 2.6.4 Electronic Overload Protection

The CKBLTP12 Air Compressor was designed to run on 12 volts of power at 90 amps of continuous draw. Connecting the compressor to power sources that cannot supply 90 amps at 12 volts may result in voltages being pulled down or amperages increasing beyond the safe level of 90 A (45 A per motor).

If the compressor is allowed to continue to run at low voltage or at high amperage then eventually damage will be done to the motors or wiring, or one of the motors may suffer a stall when trying to start up. For this reason this CKBLTP12 is electronically overload protected. When excessive loads are detected then it will attempt to reduce current draw on the power source by intentionally slowing down the compressor's run speed. If the lowest effective run speed still cannot bring current draw under control then it will turn off just one of its two motors. This allows itself to run as a single compressor to see if that reduces the load on the power source enough to get the amps and volts to within acceptable levels. If the power source still cannot support running as a single compressor then it will simply turn the remaining motor off.

Any motor that has stopped due to a fault condition will show a series of blinks/flushes of the isolation switch and also play an audible series of beeps.

Once stopped the motor will remain in this state until the isolation switch is cycled OFF/ON where it will again attempt to run at full speed.

The number of blinks/flushes/beeps pertains to a code which can be identified in Section 2.6.5 (System Fault Codes).

## 2 Safe Air Compressor Operation

### 2.6.5 System Fault Codes

When an ARB Brushless Air Compressor stops running for any reason other than the preset pressure being achieved, the motor should communicate the reason for the stop using a sequence of 'beeps' produced within the motor. The same sequence will also be visible in the blinking/flushing of the illumination of the dashboard Air Compressor switch.

Below are the faults indicated by each sequence:

| NUMBER OF BEEPS | SYSTEM FAULT CODE                               | POSSIBLE CAUSE(S) OF FAULT  |
|-----------------|---|---|
| 1               | Electronic speed controller is over temperature | Ambient temperature too high / cooling system blockage / cooling fan fault / too little ventilation around compressor |
| 2               | Compressor head is over temperature             | Ambient temperature too high / cooling system blockage / cooling fan fault / too little ventilation around compressor |
| 3               | Compressor stalled or failed to start-up        | Mechanical fault prohibiting rotation / blockage or fluid in compression chamber                                      |
| 4               | Power supply is under voltage (V)               | High resistance in power supply wiring / insufficient power supply (battery/alternator) / poor body ground            |
| 5               | Power supply is over voltage (V)                | Vehicle charging system fault / incorrect body grounding  |
| 6               | Current draw (A) is too high to continue        | Supply voltage is too low / output pressure too high (blow-off valve fault) / mechanical fault                        |
| 7               | Motor position hall sensor fault                | Magnetic disturbance / circuit board fault  |
| 8               | Compressor free run time limit                  | Compressor was running free for too long so an air system failure was suspected and compressor stopped                |

**NOTE : All fault stoppages can be reset by turning the switch OFF then ON again.**

### 3.1 Air Filter Service

The ARB CKBLTP12 comes factory fitted with high density, high flow, sintered bronze air filters to protect the compressor components, and any accessories that might be used with the compressor, from damage caused by the ingress of dirt and fine dust particles. The filter elements are removable and cleanable and should provide for years of continuous service.

Follow the steps below to disassemble, clean and re-assemble the air filters.

- Unscrew the air filters from the compressor.
- Remove the air filter cover from the air filter base by applying slight prying pressure under the fingers of the cover.
- Remove the filter element disk.
- Vigorously wash the element in a solution of hot soapy water.
- Rinse the element in pure hot water.
- Dry thoroughly.
- Insert the element back into the air filter base making sure that the flattest/smoothest face of the disk faces toward the filter base.
- Snap the air filter cover back onto the base and rotate the cover into the desired position.
- Install the air filters back into the compressor.

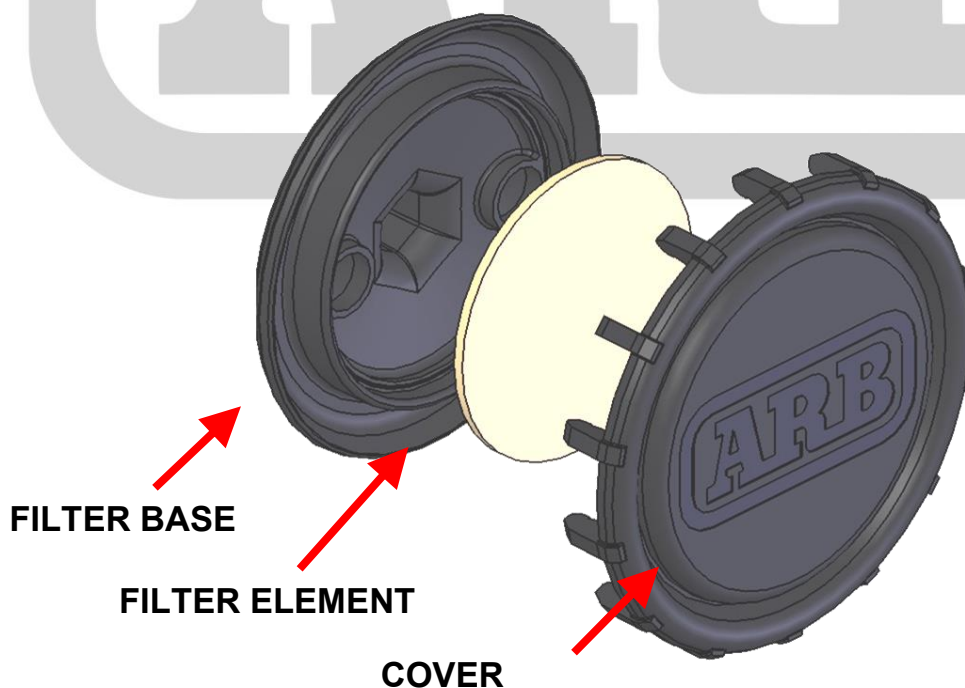

## 3 Service and Maintenance

### 3.2 Wiring Harness Replacement

The CKBLTP12 power supply harness is connected to the compressor by a connector that is rated for high current. Should the harness or battery clamps be damaged and need replacement the supply harness can simply be unplugged and replaced.

If the power supply harness is replaced with an alternative harness then every caution must be taken to assure that only correct polarity is supplied, as any connection made with incorrect polarity, even with the isolating switch in the OFF position, will result in catastrophic damage to both motors of the air compressor.

### 3.3 Draining Moisture from the Air Tank

After prolonged compressor use, moisture can accumulate in the air tank and as a result the air tank should be drained after approximately 10-20 hours of compressor run time. The air tank can be drained as follows:

- With the compressor connected and switched on as described in Section 2.2 (Connecting for Use), connect the air blow gun to the air hose.
- With the compressor sitting parallel to the ground, operate the blow gun with the nozzle pointing towards the ground and away from people. Press the blow gun trigger and any accumulated moisture in the air tank will be expelled through the blow gun.

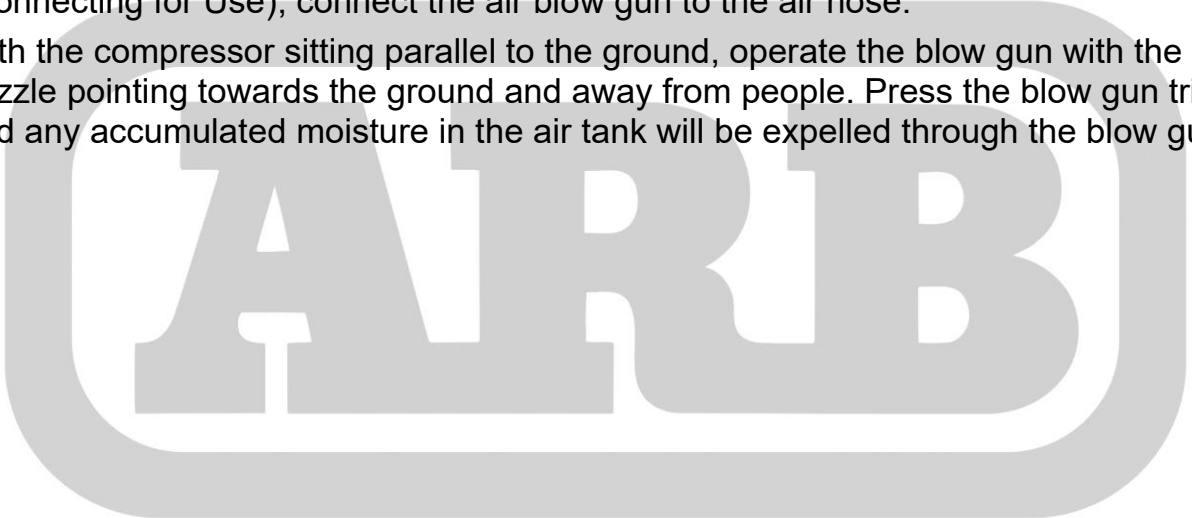

## 4 Parts List

# CKBLTP12

## Brushless Twin Portable Compressor

| ITEM #                          | QTY | DESCRIPTION                | PART #   | NOTES | ITEM #            | QTY | DESCRIPTION                    | PART #  | NOTES |
|---------------------------------|-----|----------------------------|----------|-------|-------------------|-----|--------------------------------|---------|-------|
| <b>CASE AND ACCESSORIES</b>     |     |                            |          |       | <b>COMPRESSOR</b> |     |                                |         |       |
| 1                               | 1   | CARRY CASE                 | 270110   |       | 17                | 2   | MOTOR ASSEMBLY                 | 330104  |       |
| 2                               | 1   | BLOW GUN                   | 171309   |       | 18                | 4   | HEX BOLT (M6 x 80 mm)          | 200719  | 5     |
| 3                               | 1   | AIR HOSE (7 m)             | 171301V2 |       | 19                | 2   | AXLE                           | 320232  | 1     |
| *                               | 1   | POLARITY CORRECTION CLAMPS | 180437   | 2     | 20                | 2   | RETAINING RING (DIN7993 RW-14) | 6151767 | 1     |
| *                               | 1   | INFLATION ACCESSORY KIT    | 171303V2 | 2     | 21                | 2   | CAP SCREW (M6 x 25 mm)         | 200718  | 1, 8  |
| <b>CHASSIS AND AIR FITTINGS</b> |     |                            |          |       | <b>COMPRESSOR</b> |     |                                |         |       |
| 4                               | 1   | WIRING HARNESS             | 180436   |       | 22                | 2   | O-RING (BS029N70)              | 160250  | 1     |
| 5                               | 2   | HEX NUT (NYLON LOCKING M3) | 6151703  |       | 23                | 2   | AIR FILTER FLANGE              | 320212  |       |
| 6                               | 2   | SCREW (M3 x 20 mm)         | 6152224  | 3     | 24                | 4   | HEX BOLT (M6 x 10 mm)          | 6151496 | 5     |
| 7                               | 1   | CHASSIS                    | 330222   |       | 25                | 2   | AIR FILTER ASSEMBLY            | 320501  | 1     |
| 8                               | 1   | ROCKER SWITCH              | 180221   |       | 26                | 1   | COMPRESSOR MOUNT ASSEMBLY      | 330110  |       |
| 9                               | 1   | HOSE COUPLING              | 171403   | 7     | 27                | 1   | HEAT SHIELD                    | 330224  |       |
| 10                              | 1   | AIR TANK (4 L)             | 170507   |       | 28                | 1   | COMPRESSOR HEAD                | 330209  |       |
| 11                              | 2   | AIR TANK BRACKET           | 330221   |       | 29                | 2   | O-RING (CUSTOM SIZE)           | 160907  | 1     |
| 12                              | 4   | HEX BOLT (M6 x 10 mm)      | 6151496  | 5     | 30                | 1   | MANIFOLD TUBE                  | 330215  |       |
| 13                              | 1   | HARD AIR LINE              | 330227   | 6     | 31                | 1   | MANIFOLD CAP (1/4" NPSC)       | 330216  |       |
| 14                              | 1   | HARD AIR LINE              | 330228   | 6     | 32                | 2   | O-RING (METRIC 2 x 6 mm)       | 160908  | 1     |
| 15                              | 2   | HARNESS CLIP               | 15427170 |       | 33                | 2   | FLAT WASHER (M6)               | 6151046 | 1     |
| 16                              | 6   | SCREW (M6 x 12 mm)         | 6152225  |       | 34                | 1   | PRESSURE SWITCH (150 psi)      | 180912  | 4     |
|                                 |     |                            |          |       | 35                | 1   | SAFETY VALVE POPPET            | 320205  | 1     |
|                                 |     |                            |          |       | 36                | 1   | SAFETY VALVE SPRING            | 150115  | 1     |
|                                 |     |                            |          |       | 37                | 1   | SAFETY VALVE FITTING           | 320204  | 1, 4  |
|                                 |     |                            |          |       | 38                | 2   | HEX BOLT (M6 x 100 mm)         | 200720  | 1, 5  |
|                                 |     |                            |          |       | 39                | 1   | ADAPTOR (1/4 NPSC JIC-4 M-M)   | 170633  | 4     |
|                                 |     |                            |          |       | 40                | 6   | O-RING (BS032S70)              | 160247  | 1     |
|                                 |     |                            |          |       | 41                | 2   | VALVE PLATE ASSEMBLY           | 320105  | 1     |
|                                 |     |                            |          |       | 42                | 2   | PISTON ASSEMBLY                | 320103  | 1     |
|                                 |     |                            |          |       | *                 | 1   | COMPLIANCE STICKER             | 2128752 | 2     |

- 1 Included in Complete Overhaul Kit (P/N 180914) – two kits required for twin compressors
- 2 Not illustrated in exploded view
- 3 Torque to 1 Nm
- 4 Torque to 4 Nm
- 5 Torque to 6 Nm
- 6 Torque to 10 Nm
- 7 Torque to 15 Nm
- 8 Torque to 13 Nm and add thread lock



# CKBLTP12

## Air Compressor – Exploded Parts Diagram

### CASE AND ACCESSORIES

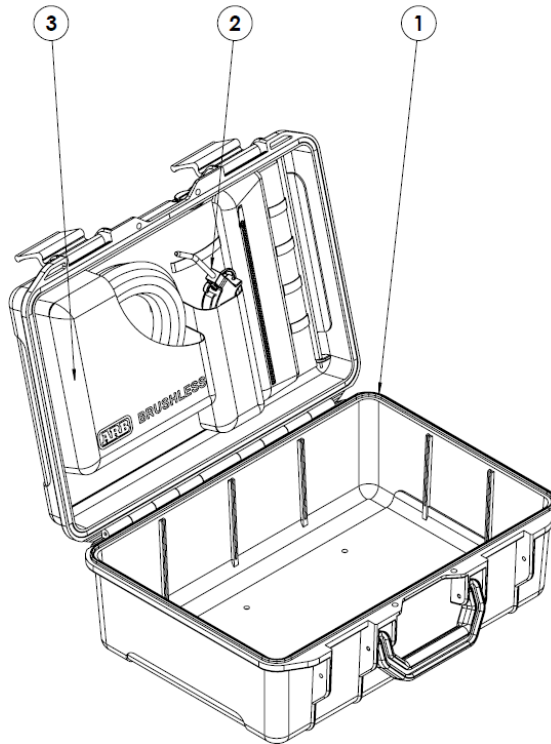

### CHASSIS AND AIR FITTINGS

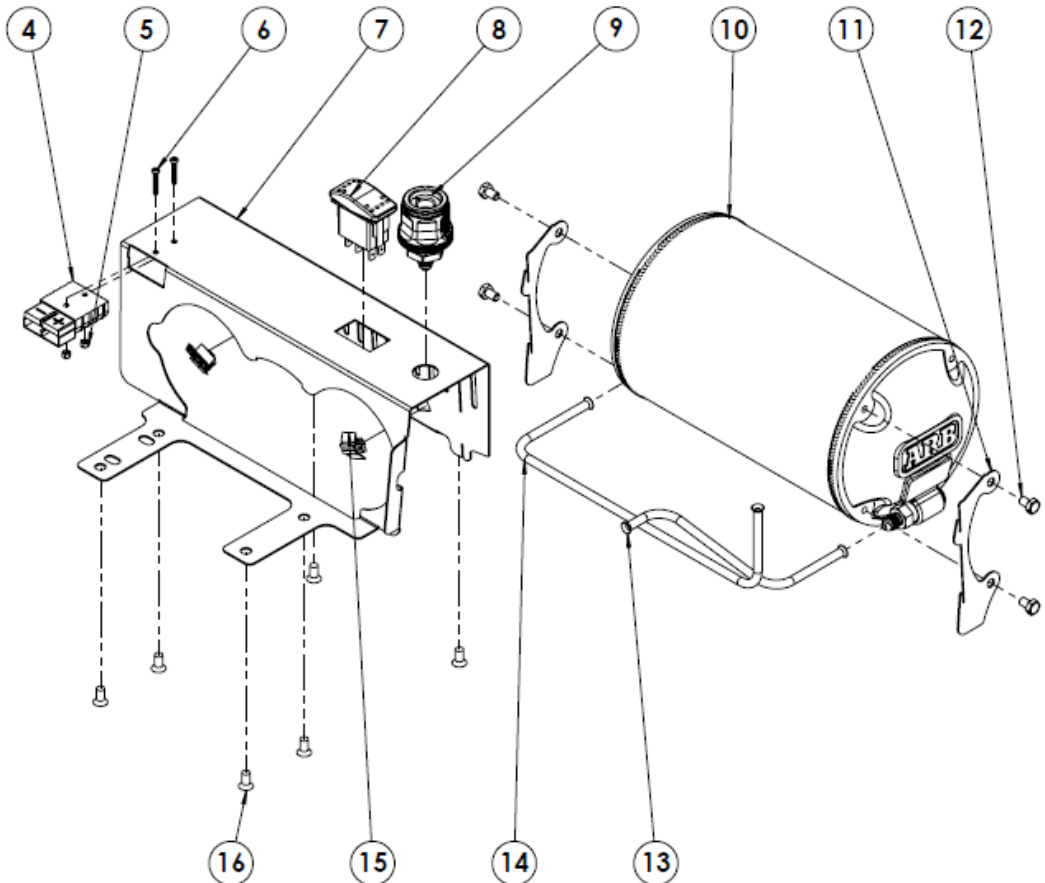

# 4 Parts List

## COMPRESSOR

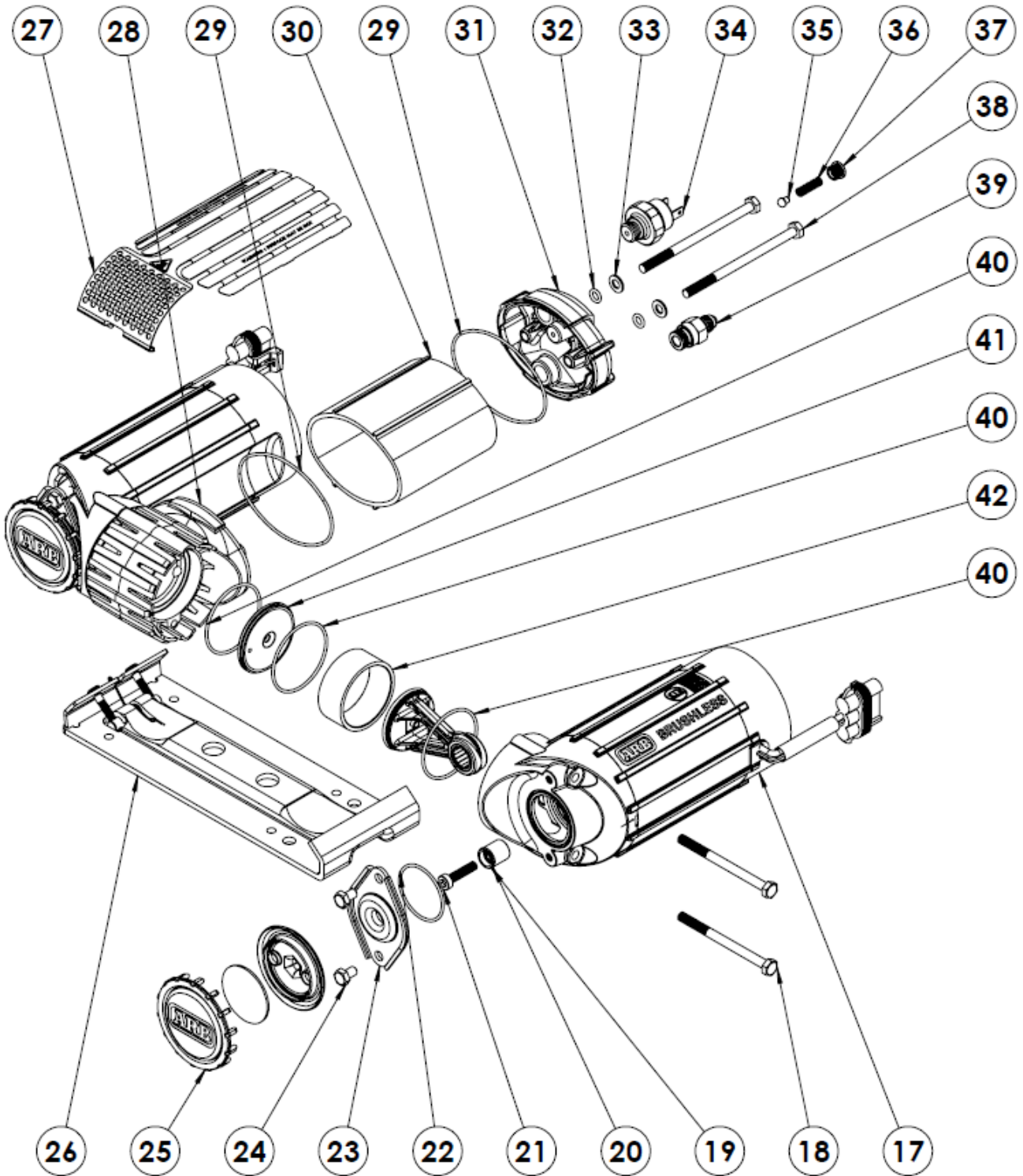

## 4 Parts List

# CKBLTP12

## Air Compressor – Detailed Specifications

| GENERAL SPECS                     |          | METRIC |   | IMPERIAL |          |
|-----------------------------------|----------|--------|---|----------|----------|
| SUPPLY VOLTAGE                    |          | 12     | Volts DC  | 12       | Volts DC |
| MAX CURRENT DRAW (each motor)     |          | 45     | Amps  | 45       | Amps     |
| WEIGHT (total kit)                |          | 13.3   | kg  | 29.3     | lb       |
| DIMENSIONS                        | - LENGTH | 478    | mm  | 18.8     | in       |
|                                   | - WIDTH  | 355    | mm  | 14.0     | in       |
|                                   | - HEIGHT | 186    | mm  | 7.3      | in       |
| DUTY CYCLE                        |          | 90%    | 54 minutes running per hour<br>22 °C, 200 kPa [72 °F, 29 psi] |          |          |
| PRESSURE SWITCH CLOSED (motor on) |          | 930    | kPa   | 135      | psi      |
| PRESSURE SWITCH OPEN (motor off)  |          | 1030   | kPa   | 150      | psi      |
| SAFETY VALVE PRESSURE             |          | 1240   | kPa   | 180      | psi      |
| MAX. AMBIENT TEMPERATURE          |          | 100    | °C  | 212      | °F       |

| SPECS at NO LOAD |  | METRIC |       | IMPERIAL |      |
|------------------|--|--------|-------|----------|------|
| TEST PRESSURE    |  | 0      | kPa   | 0        | psi  |
| CURRENT DRAW     |  | 30     | Amps  | 30       | Amps |
| AIR FLOW         |  | 260    | L/min | 9.2      | CFM  |

| SPECS at TYRE PRESSURE |  | METRIC |       | IMPERIAL |      |
|------------------------|--|--------|-------|----------|------|
| TEST PRESSURE          |  | 200    | kPa   | 29       | psi  |
| CURRENT DRAW           |  | 80     | Amps  | 80       | Amps |
| AIR FLOW               |  | 176    | L/min | 6.2      | CFM  |

**NOTE:** The specifications above were recorded under laboratory conditions at 22°C [72°F].

| EXTERNAL CONNECTIONS SPECS  |   |
|---|---|
| AIR INTAKE THREADS (female)                                       | 1/4-18 NPSC (parallel pipe thread)  |
| AIR FILTER THREAD (male)  | 1/4-18 NPT (tapered pipe thread)  |
| MANIFOLD OUTLET THREAD  | 1/4-18 NPSC (parallel pipe thread)  |
| AIR COUPLING FITTING TYPE<br>(international equivalent standards) | 'US Industrial Standard'<br>ISO 6150 B, US.MIL.C 4109,<br>Legris series 23, Rectus series 23/24/1400, Tema series 1400,<br>DYNAQUIP D3, CEJN 310, Norma / AFNOR: NF.E49.053,<br>Parker series 30-1/4" and 20-1/4", Aignep 220, Hansen series 3000,<br>Norgren series 237, Gromelle series 600 |