

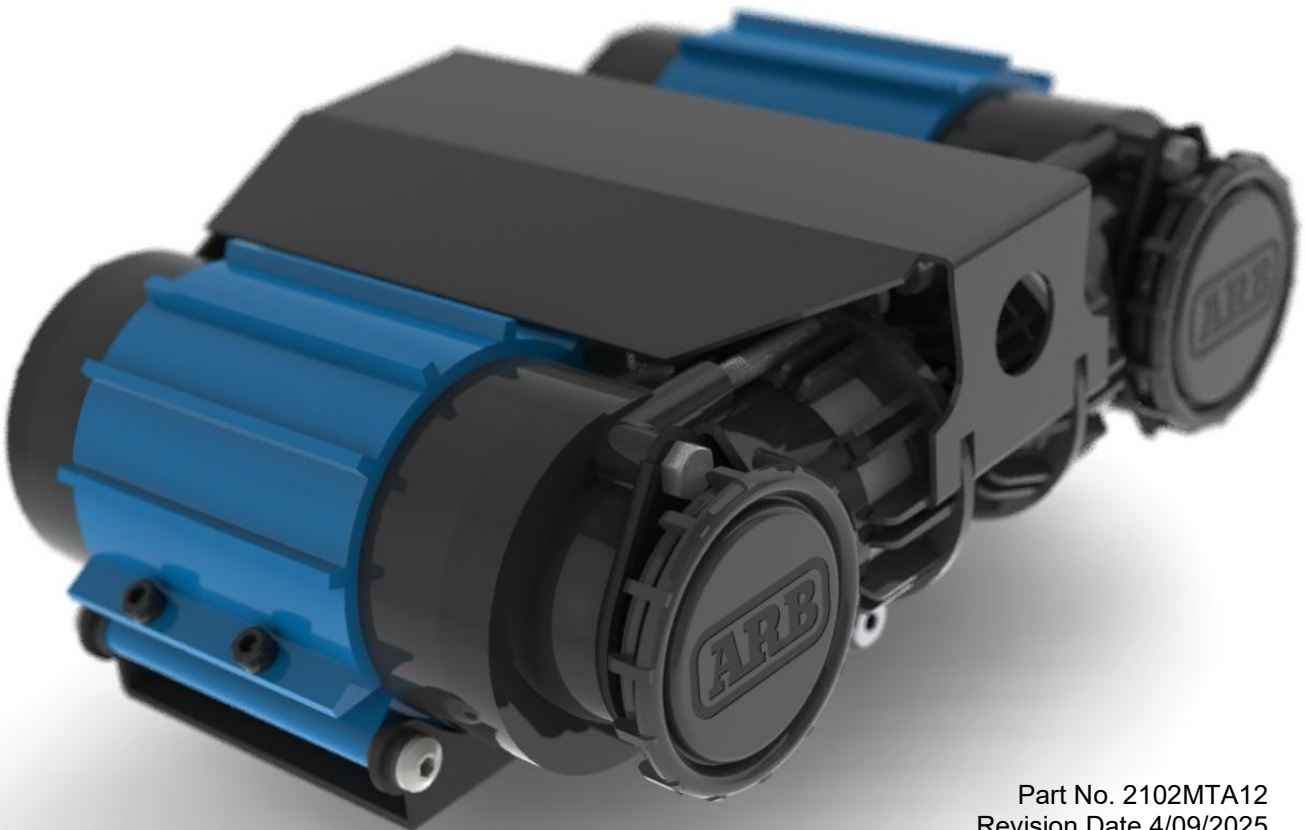

**MAXIMUM PERFORMANCE
ON-BOARD AIR SUPPLY
*INSTALLATION GUIDE***

CKMTA12 / 24



Part No. 2102MTA12
Revision Date 4/09/2025
Copyright © 2013 by ARB Corporation Limited

No liability is assumed for damages resulting in the use of the information contained herein. ARB Air Locker Air Operated Locking Differentials, ARB Air Locker Air Activation System and Air Locker are trademarks of ARB Corporation Limited. Other product names used herein are for identification purposes only and may be trademarks of their respective owners.



EC Declaration of Conformity

This declaration of conformity is issued under the sole responsibility of the manufacturer.

This declaration relates to these products:

CKMTA12

CKMTA24

The products are in conformity with the following standards or standardized documents:

EN 55014-1 : 2003 (AS/NZS CISPR 14.1)

EN 55014-2 : 2003 (AS/NZS CISPR 14.2)

According to the provisions of the directives:
2004/108/EC (EMC directive).

Technical file at:

ARB Corporation Ltd, 42-44 Garden St, Kilsyth, Victoria, Australia.

Signed for and on behalf of ARB Corporation Ltd

A handwritten signature in black ink, appearing to read 'Andrew Brown', is written over a horizontal line.

Andrew Brown
Managing Director
Melbourne, March 2016

ARB 4x4 ACCESSORIES

Corporate Head Office

42-44 Garden St
Kilsyth, Victoria
AUSTRALIA
3137

Tel: +61 (3) 9761 6622

Fax: +61 (3) 9761 6807

Australian enquiries
North and South American enquiries
Other international enquiries

sales@arb.com.au
sales@arbusa.com
exports@arb.com.au

www.arb.com.au

Table of Contents:

1	Introduction	2
1.1	Pre-Installation Preparation	2
1.2	Tool-Kit Recommendations	2
2	Installing the Compressor	3
2.1	Identifying the Best Mounting Position	3
2.2	Orientating the Compressor for Best Fit	4
2.3	Drilling & Mounting the Compressor	6
2.4	Assembling / Installing the Air Filter	8
2.5	Using an Air Filter Extension Tube (optional)	8
3	Connecting the Air System	10
3.1	Compressor Outlet Port Connections	10
4	Mounting & Connecting the Electrical System	12
4.1	Mounting the Actuator Switch(es)	12
4.2	Wiring the Actuator System	13
4.3	Connecting the Power Wires	16
5	Testing & Troubleshooting	18
5.1	Leak Testing	18
5.2	Testing the Air Locker Actuation (Air Locker Systems Only)	18
5.3	Electrical Fault Diagnosis	19
5.4	Post-Installation Check List	22
6	Parts List	24
6.1	Parts List	24

1 Introduction

IMPORTANT :

To assure the highest level of planning and reliability goes into this installation, **please read this guide in its entirety** before attempting any modifications to the vehicle.

FOR HIGH VOLTAGE (HV) ELECTRIC VEHICLES



Work on and fitting parts to High Voltage (HV) electric vehicle which have the potential to involve an interaction with the HV systems on that vehicle presents significant risks of serious injury or death due to electric shock, arc flashes and potential explosions or fires.

When undertaking work or fitting parts that will likely involve an interaction with the vehicles HV system, appropriately qualified personnel must undertake such work or fitment of those parts in accordance with company procedures and local regulatory requirements. The qualifications required may vary depending on the location or region.

Failure to comply with these requirements and instructions may result in serious injury or death.

1.1 Pre-Installation Preparation

Although your *ARB Air Compressor* comes complete with all the step-by-step instructions you will need to install your new air source, ARB recommends that you have your ARB Air Compressor installed by a trained professional. Many ARB distributors around the world have been fully instructed in *Air Compressor* installations by ARB, and have gained a wealth of experience and skill from years of performing similar installations.

Make sure your *Air Compressor* kit is the correct model for your application and that it contains all of the parts listed on the back cover of this booklet. Also be sure you have appropriately equipped yourself with all the necessary tools, parts, and materials to complete this installation (see section 1.2 *Tool-Kit Recommendations*) and minimize vehicle down time.

Please refer to your ARB Air Locker Operating & Service Manual for information on operating, servicing, driving technique, or trouble shooting your ARB Air Locker(s).

HINT : Place a ✓ mark inside each of the symbols as you complete each step. It is very important NOT to miss any of the steps!

1 Introduction

1.2 Tool-Kit Recommendations

Below is a list of tools and supplies you may need to complete this installation.

1.2.1 Tools

- Standard automotive sizes (metric and/or imperial) of sockets, wrenches and drills.
- A razor knife to cut the nylon tubing.
- A leak test gauge (i.e., ARB# 0770005).
- A multimeter or test light.
- A soldering iron.

1.2.2 Supplies

- Thread lubricant/sealant compound for pressure fittings (e.g., LOCTITE #567 Teflon paste and/or plumbing supply Teflon tape)
- A soap and water mixture to test for air leaks.
- Solder and/or automotive crimp fittings for making electrical junctions.
- Electrical tape and/or heat shrink tubing for insulating electrical junctions.

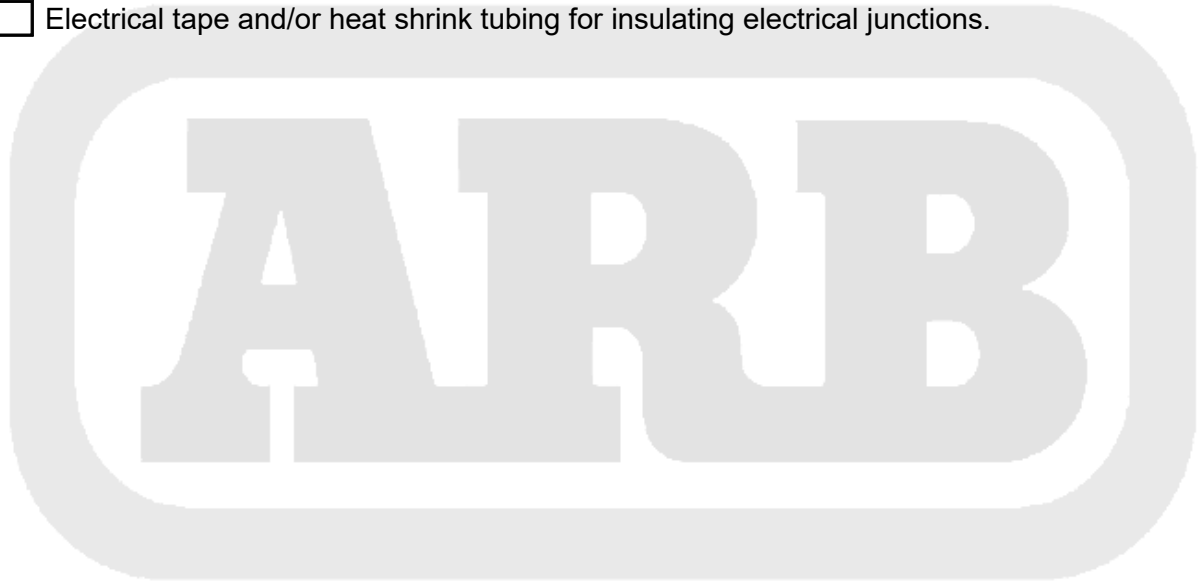

2 Installing the Compressor

2.1 Identifying the Best Mounting Position

- Using the following points as guideline, identify a position on the vehicle or inside the cabin where the compressor can be safely and conveniently mounted.

NOTE : The ideal position of the compressor should give consideration to all of the following points:

1. The location should allow for quick and easy access to the compressor for attaching an optional pump-up kit air hose for tire re-filling if desired.
2. Keep away from sources of heat (e.g., too close to exhaust system components or directly behind the radiator, etc.).
3. The position should be safe from damage or abrasion caused by sand or gravel from the road surface.
4. Avoid any extended exposure to direct sunlight.
5. Keep away from excessive moisture (e.g., directly exposed to road spray or rain runoff).
6. Mounting location should be above the highest possible waterline to avoid submerging during water crossings.
7. The position must allow free flow of dry, cool air to the air filter assembly (unless an intake extension tube is to be used, in which case it is the filter assembly and the extension tube which must be located accordingly).
8. The position should allow access to the air filter assembly for filter disassembly and cleaning (unless an intake extension tube is to be used).
9. If an intake extension tube is to be used then consideration should be given to the intake position so that the distance (length of tube) between the compressor mounting location and the actual air intake point can be kept to a minimum.
10. The position must allow the compressor motor mounting bracket to firmly secure the compressor using all 4 bolts provided.
11. The position must allow access to the opposite side of the mounting location so that the bolts and washers may be installed.
12. Parts of the compressor may get hot while running for long periods of time, and therefore the compressor should be located away from where it could be touched by children or pets.
13. The position should permit a short (close to the battery), protected and accessible route for the wiring loom to follow.
LONGER POWER WIRES = MORE INLINE RESISTANCE = LESS AIR FLOW RATE
14. The compressor should not be mounted in a position where the running sound might be considered startling or irritating for vehicle occupants.
15. The compressor should not be mounted in close proximity to devices that are sensitive to the electromagnetic fields of DC motors (e.g., compasses, radio/GPS antennas, engine management sensors, etc.).
16. Where possible, the compressor should be mounted close to the location of the *Air Locker* equipped axle in a single *Air Locker* system, or halfway between both axles in a dual *Air Locker* system.
17. Never mount the compressor in a position where it would be considered unsprung mass (e.g., mounted directly to the axle or the engine block).

2 Installing the Compressor

2.2 Orientating the Compressor Outlet for Best Fit

The CKMTA series compressors allow for configuring the outlet port to best suit the installation position and desired position of the outlet hose or coupling (see Fig 1). It is highly recommended to spend some time experimenting with different configurations prior to drilling the four mounting holes.



Figure 1.

The points and figures below outline how to remove the compressor cover in order to orientate the outlet port.

- Unplug the two motor connectors and remove the four cover bolts (10mm socket).

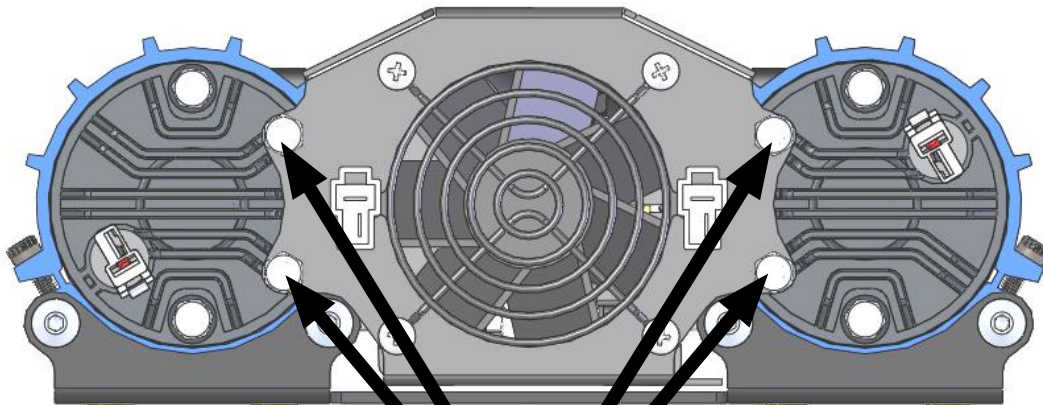
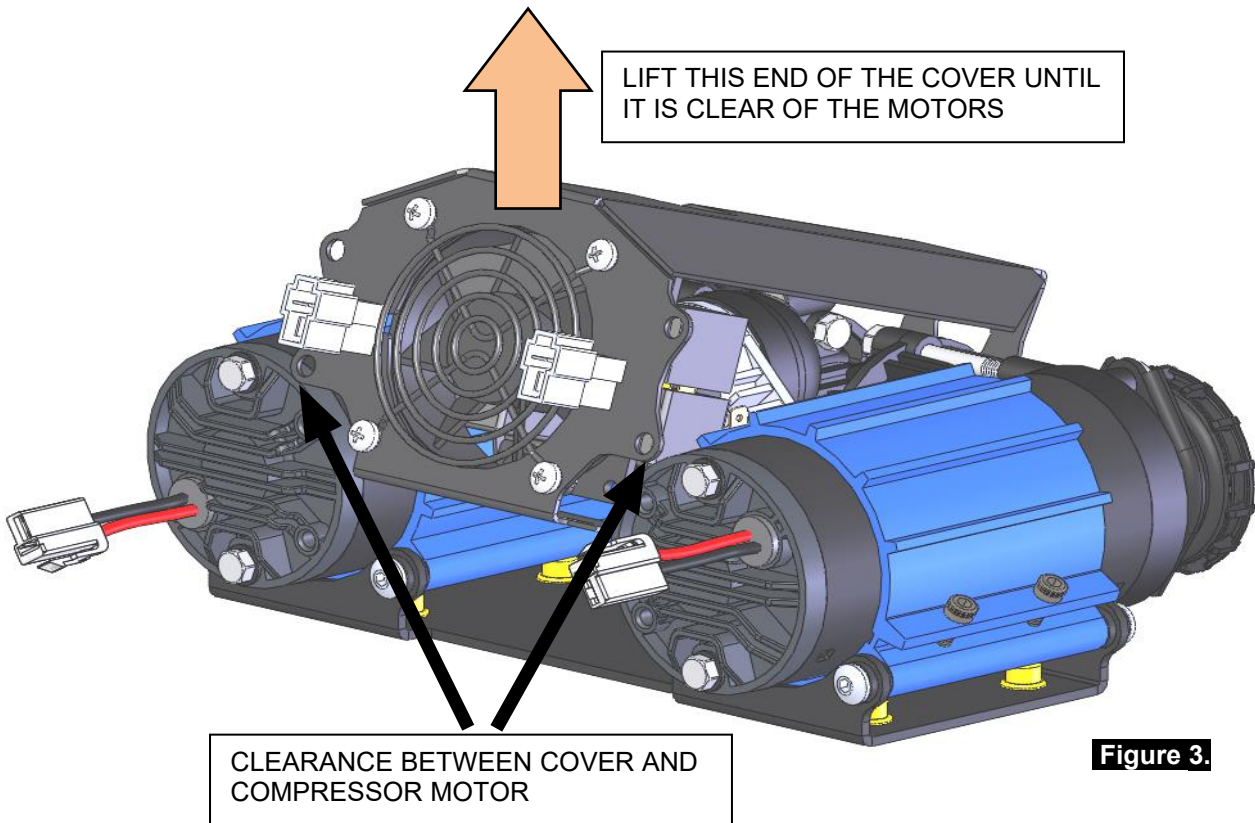

Figure 2.

REMOVE COVER BOLTS

2 Installing the Compressor

- Gently lift the cover upward from under the fan until it is just above the compressor motors.



- Slide the cover towards the intake filter end to unhook the cover from the compressor head.
- Unplug the connectors from the pressure switch and lift the cover away from the compressor.

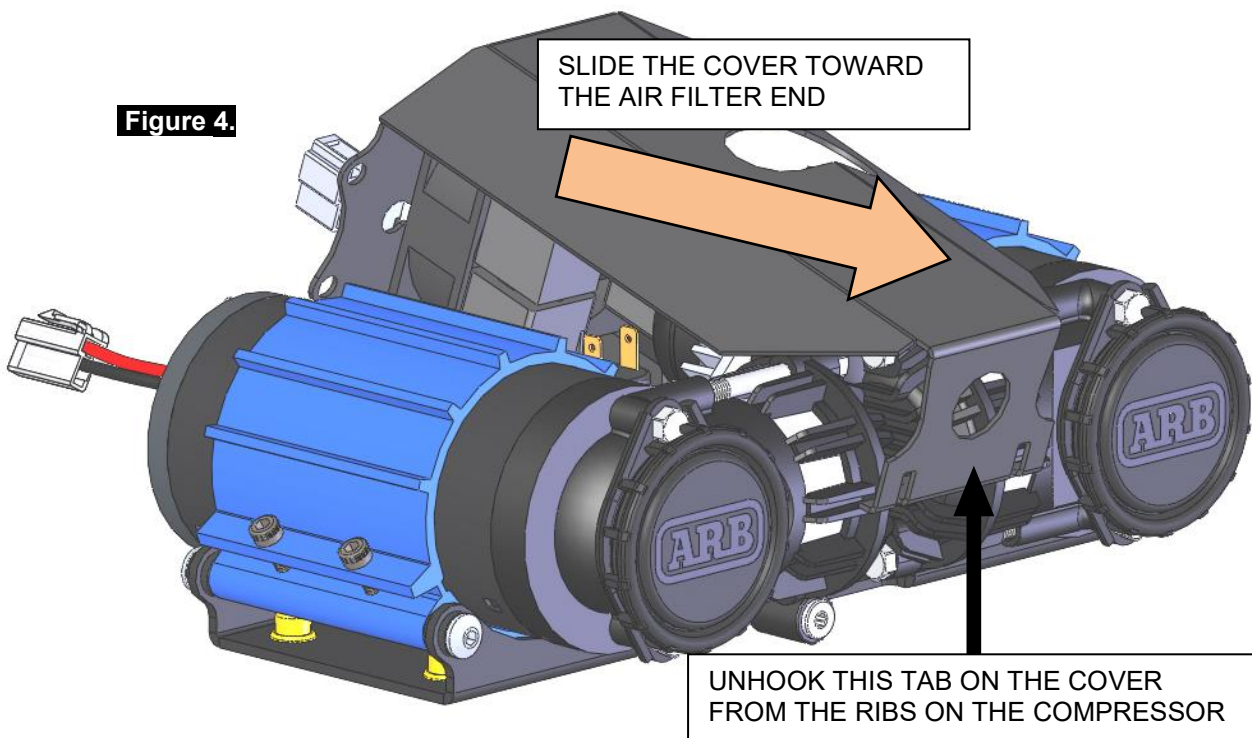

2 Installing the Compressor

- Loosen the manifold bolt (10mm socket) and rotate the outlet port to the desired position.

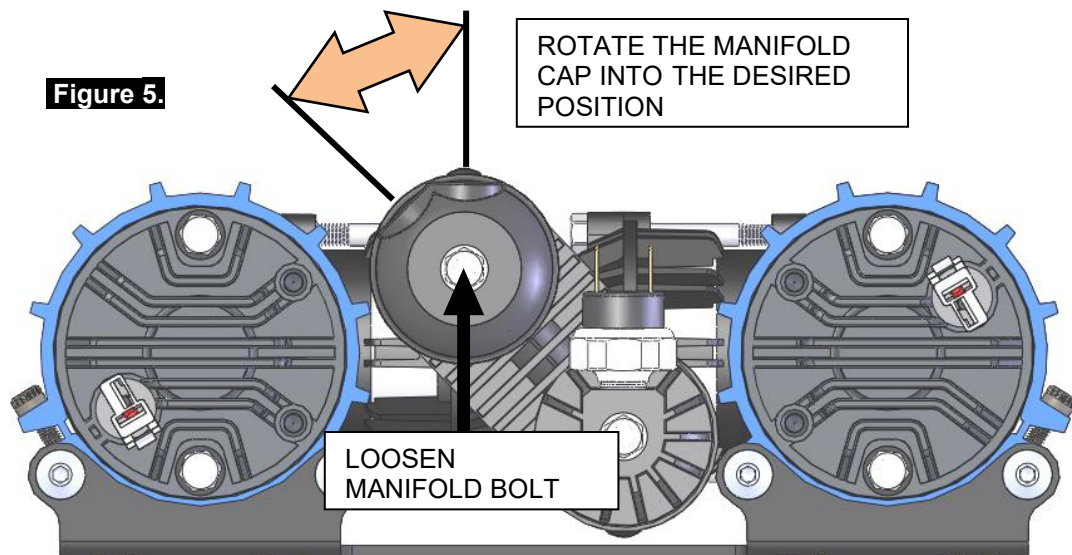

- Retighten the manifold bolt (10mm socket) to approximately 9 Nm [6.6 ft-lb].
- Refit the cover reversing the above operations.

NOTE : Polarity isn't important when reconnecting the pressure switch connectors.

NOTE : Retighten the four cover bolts (10mm socket) to 6 Nm [4.4 ft-lb].

2.3 Drilling & Mounting the Compressor

- Establish the mounting hole locations for the compressor from the mounting bracket drill template Fig. 6.

NOTE : For greater mounting flexibility eight mounting nuts are provided in the mounting bracket but only four must be used. Choose one hole from each pair (A, B, C, D) shown in Fig. 6, to best suit your installation location. This will ensure that the weight of the compressor is well distributed.

- Drill four mounting holes at a diameter of 8mm [5/16 inch].

NOTE : Try to drill mounting holes accurately. Holes should never be drilled open to more than 10mm [3/8 inch] in size to compensate for misalignment.

- Assemble the hex bolts and washers from the opposite side, through the newly drilled hole in the panel and into the nuts in the mounting bracket.
- Tighten to a torque of approximately 6 Nm [4.4 ft-lb].

Figure 6.

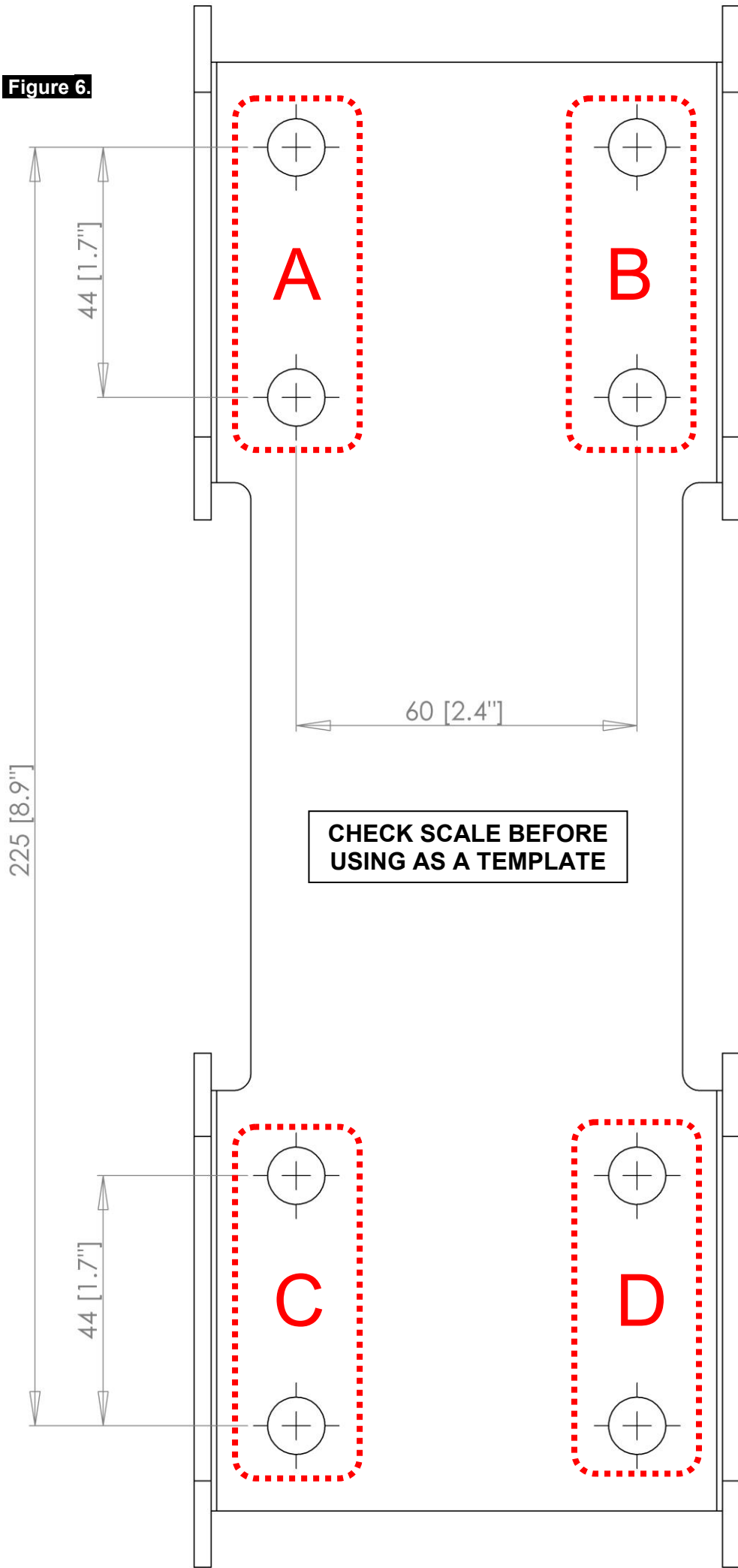

2 Installing the Compressor

2.4 Assembling / Installing the Air Filter

- Screw the air filter assembly into the threaded hole in the front of the compressor by hand.

NOTE : If an intake extension tube is to be used to relocate the air intake then the extension tube will be screwed into the front of the compressor and the air filter will be screwed into the extension tube (See section 2.7).

HINT : If extra tightening force is required, the air filter can be tightened by disassembling the cover, removing the filter disk, and using an 8mm [5/16"] hex key on the center of the port.

- The cover logo may be rotated by hand as desired.

2.5 Using an Air Filter Extension Tube (optional)

The air filters of the CKMTA were designed so that they could be relocated to a more suitable location (if required) using an extension tube.

IMPORTANT :

The length and inside diameter of the extension tube can restrict the intake flow and negatively affect the performance of the compressor. In severe cases this could result in overheating and/or damage to compressor components. Use the following chart to make sure that the extension tube will not restrict the intake flow.

- Measure the intended length of the extension tube along the path between the compressor mounting location to where the air filter will be mounted.

Maximum Length of Tube		Minimum Inside Diameter of Tube
150mm [5.9"]	=	8mm [0.32"]
400mm [15.7"]	=	10mm [0.39"]
885mm [34.8"]	=	12mm [0.47"]
1715mm [67.5"]	=	14mm [0.55"]
3065mm [120.7"]	=	16mm [0.63"]

NOTE : There is no minimum length or maximum inside diameter for extension tubes.

- Consult the chart above for the recommended minimum inside diameter of the tube.

NOTE : If intending to join the two intakes into one extension tube then halve the values in the 'Maximum Length of Tube' column above.

NOTE : ARB does not recommend connecting the compressor intake to the air supply in a 'snorkel' or other part of the air ducting for engine aspiration. However, if an extension tube is used to relocate the compressor intake to the engine intake supply then it must be understood that the negative pressure (vacuum) created by the engine when it is running will adversely affect compressor performance.

NOTE : Do not run the tube through areas where it will be exposed to elevated temperatures while the compressor is running as this will pre-heat the air intake and reduce compressor performance.

2 Installing the Compressor

- Assemble an extension tube with a ¼" NPT male fitting at one end and a ¼" NPT female end at the other.
- Install the tube inline with the air filter.

NOTE : If the extension tube is being used due to the possibility of the compressor being exposed to water then Teflon tape or thread sealant should be used on the threads of the extension tube at the compressor end.

- Secure loose sections of the tube and the air filter.

HINT : The air filter assembly may be easily panel mounted if desired by securing the air filter base using the 2 bosses located on the inside of the filter base for countersunk screws.



3 Connecting the Air System

3.1 Compressor Outlet Port Connections

The CKMTA series compressors can be used for a vast number of compressed air applications including, Air Locker activation, tire inflation and hand air tool operation. Each of these compressed air applications has different requirements of the outlet port connections and some of these setups are outlined below:

3.1.1 Connection for Air Locker Activation

Air Locker Manifold Kit ARB #171503 is available as an optional accessory to enable the installation of Air Locker solenoids. The Air Locker Manifold Kit is shown in Fig. 7 and includes:

- Manifold body with mounting bracket
- 2 x 1/8" BSPP ports for installation of up to 2 x Air Locker solenoids
- 2 x 1/4" NPT ports, one to be used as an input and the second could be used for installation of a pump up kit
- 1 x high temperature resistant Teflon stainless steel braided hose with heavy duty JIC4 fittings
- 2 x JIC-4 - 1/4" NPT nipples to connect the included hose to the compressor outlet and manifold kit input
- 2 x M6 hex head bolt and nylon lock-nuts for securing the manifold kit

NOTE : The Air Locker solenoids (ARB #180103) and hose coupling (ARB #171402) shown in Fig 7. are not included in the Air Locker Manifold Kit.



3 Connecting the Air System

3.1.2 Connection for Tire Inflation

If the CKMTA12/24 compressor is to be used for prolonged periods then it is recommended that the compressor be connected using suitable fittings to a separate air tank. This will dissipate the heat from the compressed air and also allow the compressor to run more efficiently.

If the compressor is to be used for Air Locker activation and inflating several tires then fitment of the Air Locker Manifold kit mentioned in section 3.1.1 would be suitable. This allows for fitment of a hose coupling ARB #171402 as shown in Fig. 7 (which is available separately in Pump Up Kit ARB #171302).

Do not directly attach a hose coupling to the outlet port of the compressor. Heat from prolonged continuous operation of the compressor can damage flexible hosing. To prevent the likelihood of hose damage, connect the compressor outlet to a tank or remote hose coupling to allow the heat to dissipate before reaching flexible hosing.

IMPORTANT :

Due to the fact that compressing air at a high rate produces a lot of heat, if the compressor is used for a prolonged period to inflate more than a few tires, a hose or coupling fitted directly to the compressor outlet will get hot.

3.1.3 Connection for Hand Air Tool Operation

For prolonged compressor use and the effective operation of hand air tools then it is recommended that the compressor be connected using suitable fittings to a separate air tank. Air tools with air flow requirements higher than 85LPM [3CFM] @ 6Bar [90PSI] will require the use of an air tank suitable for the run time requirements.

4 Mounting & Connecting the Electrical System

4.1 Mounting the Actuator Switch(es)

The ARB compressor switch (supplied) and *Air Locker* actuator switch(es) can be easily panel mounted inside the vehicle in a 21mm x 36.5mm [0.83" x 1.44"] rectangular cutout.

NOTE : *Air Locker* actuator switches described here are supplied with each *ARB Air Locker* kit and NOT with the ARB compressor kit. If you require switches to complete the installation then contact your *ARB Air Locker* distributor.

HINT : Only attach the cover plate to the face of the switch once the switch has been mounted and wired correctly as the cover plates are designed to be difficult to remove.

For reasons of safety and for ease of operation, the *Air Locker* actuator switch(es) should be mounted in a location picked to best suit the operator. Make sure you have taken the following points into consideration:

- Switch(es) MUST be mounted and should never be allowed to simply dangle from the wiring loom during vehicle use.
- Switch(es) should be within easy reach of the driver. Ideally, any *Air Locker* switch should be able to be operated without physical effort or distraction to the driver. (compressor switch location is not critical)
- Switch(es) should be mounted within the line of sight of the driver so that switch position ('ON' or 'OFF') can be visually determined by the rocker position and the illumination state.
- The position of the switch(es) should best eliminate any possibility of accidental operation by the driver or one of the passengers.
- Switch cutout position(s) must be located in an area with a minimum of 50mm [2"] of clearance behind the face of the cutout.
- Switch(es) should not be mounted where they will be exposed to water (e.g., in the lower section of an inner door panel).
- ARB recommends that you apply the *Air Locker* Warning Sticker (ARB part # 210101 supplied with *Air Locker* kit) within close visual proximity of the switch location.

NOTE : If no adequate position can be found on existing dashboard panels, a surface mounted bracket (Fig. 8.) may be purchased from your *ARB Air Locker* distributor to suit 1, 2, or 3 switches.



4 Mounting & Connecting the Electrical System

4.2 Wiring the Actuator System

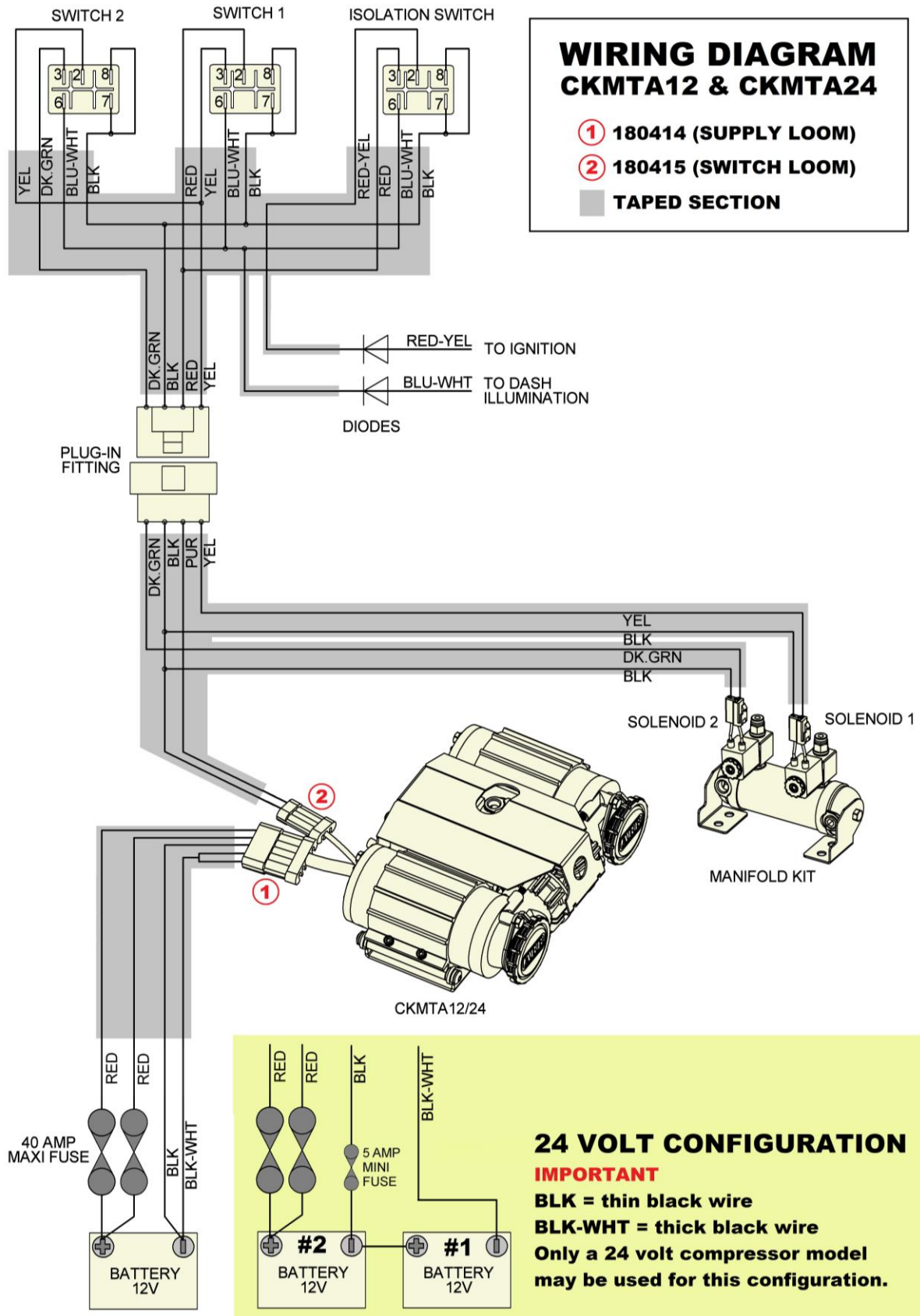

Figure 9.

4 Mounting & Connecting the Electrical System

When wiring an ARB compressor switch, *Air Locker* actuator switch(es) and *Air Locker* solenoid(s), all connections can easily be set up using only the supplied wiring looms (ARB #180414 and 180415 shown in Fig. 9.)

- Consulting the wiring diagram (Fig.9.) for wire colors, and the switch terminal illustration (Fig.10.), plug each of the female spade terminals onto their appropriate switch terminal.

IMPORTANT (Vehicle Variations) :

DUAL AIR LOCKERS: As a safety precaution, the 'SWITCH 2' position in the wiring loom will not activate unless 'SWITCH 1' is already activated. Therefore, if both front and rear Air Lockers are installed then the rear **MUST** be controlled by 'SWITCH 1', and the front by 'SWITCH 2'. This is a safety feature that serves to reduce the risk of accidental / unintended engagement of the front Air Locker.

SINGLE AIR LOCKER: If only one Air Locker is installed then it should be wired using the terminals for 'SWITCH 1', regardless of whether the Air Locker is mounted in the front or rear axle. Wire the 'ISOLATION SWITCH' according to Figure 9, and leave the 'SWITCH 2' wiring disconnected.

NO AIR LOCKERS: To install the CKMTA12 in a vehicle without Air Lockers, the spade terminal connections for 'SWITCH 1' and 'SWITCH 2' as well as Solenoid 1 and 2 can be left disconnected. Make the remaining connections according to Figure 9. The isolation switch will function as a compressor ON/OFF switch.

Unused connections must be insulated with electrical tape and attached to the harness or vehicle.

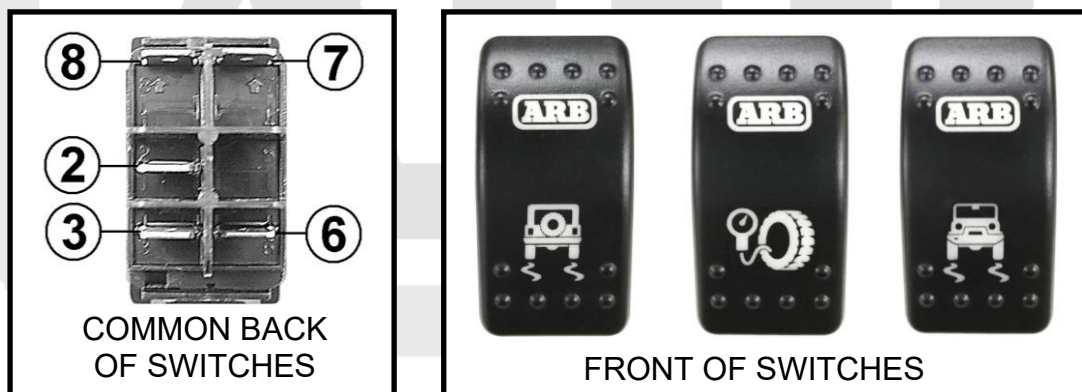

Figure 10.

- Using a multimeter or an automotive test light, locate an accessory outlet or cigarette lighter port in the vehicle.

NOTE : The desired outlet should supply positive 12VDC for a CKMAT12 or 24VDC for a CKMTA24, be fused at a minimum of 8 amps, and be live only when the vehicle ignition key is in either the 'ACC' position or in the 'ON' position.

- Using a soldering iron or automotive quality crimp connectors, splice the red wire with a yellow stripe (RED-YEL) found on the separate short section of loom onto the positive (+) wire of the accessory outlet pair.

NOTE : If shortening the RED-YEL wire, make sure not to remove the heat shrunk inline diode that protects sensitive electronics from current leakage.

4 Mounting & Connecting the Electrical System

- Insulate the junction area well with electrical tape.
- Using a multimeter or an automotive test light, locate an active dash light supply wire.

NOTE : The desired wire should supply 12VDC for a CKMTA12 or 24VDC for a CKMTA24 (less if dimmed) and react to the illumination level of the instrumentation / dash light dimmer.

- Using a soldering iron or automotive quality crimp connectors, splice the blue wire with a white stripe (BLU-WHT) found on the separate short section of loom onto the active illumination supply wire.

NOTE : If shortening the BLU-WHT wire, make sure not to remove the heat shrunk inline diode that protects sensitive electronics from current leakage.

- Insulate the junction area well with electrical tape.
- Route the 4 loose male spade terminals of the long section of loom through any panel work that separates the compressor mount position from the switches (e.g., the firewall separating the cabin from the engine compartment).

NOTE : This connection has been supplied disassembled to assist in the routing of the compressor loom through a minimum 8mm [5/16"] drilled hole in panels if necessary (e.g., through the firewall).

NOTE : If routing through a drilled hole in steel panels then a rubber insulating grommet should ALWAYS be used to protect the loom.

- Assemble the 4 spade connectors into the supplied plastic connector housing so that red wire matches up with the purple wire and each of the other wire colors matches up with the same colors on the matching connector housing of the short loom section when the 2 halves of the connector are plugged together.
- Route the remainder of the loom to the compressor mounting position.
- Plug the sealed connector to the compressor connector.
- Plug the female solenoid connector with a yellow wire (YEL) into the solenoid to be controlled by SWITCH 1.
- Plug the female solenoid connector with a green wire into the solenoid to be controlled by SWITCH 2.

NOTE : If no second solenoid is to be used then simply secure the remaining solenoid connector on the loom with a cable tie.

4 Mounting & Connecting the Electrical System

4.3 Connecting the Power Wires

IMPORTANT :

Although the wiring loom in this kit was designed to work with either a 12 volt or 24 volt system, the DC motor of the compressor has been designed **ONLY** for use on one specific voltage system.

Make sure you have the CKMTA12 compressor kit for 12V systems or the CKMTA24 for 24V systems.

Connecting a compressor to an incorrect voltage level will cause extensive damage to the compressor's DC motor, so carefully follow the power connection instructions below that apply to the vehicle.

IMPORTANT :

Never connect the power to the compressor while the vehicle key is in the ACC position, as this may result in accidental compressor start-up.

- Plug the sealed connector on the supply loom #180414 to the compressor.
- Carefully route the supply loom from the compressor mount position to the battery position.

4.3.1 Power Connection To A 12V Vehicle / System

- Trim all 4 wires to the correct length for connection to the battery.

NOTE : If any of the wires require extra length to reach the battery then splice in an extension using **ONLY** wire that is of the same gage or bigger than the wire being lengthened.

NOTE : The inline fuse should be located as close to the battery connection as possible. Never eliminate any fuses when shortening the RED wire, and only ever lengthen the RED wire on the opposite side of the fuses from the battery.

- Crimp suitable gage automotive eye terminals (not supplied) onto each of the heavy gage (5mm² [10AWG]) RED wires.
- Crimp a suitable gage automotive eye terminal (not supplied) onto the heavy gage (8mm² [8AWG]) black wire that is marked with a white stripe (BLK-WHT).

NOTE : In a 12V system the 2 black wires (BLK and BLK-WHT) will be joined together, so they may be crimped together into the same eye terminal if desired. Refer to wiring diagram in Fig 9.

- Crimp a suitable gage automotive eye terminal (not supplied) onto the lighter gage solid black wire with no stripe (BLK).
- Connect the RED wire to the positive (+) terminal of the battery by securing the eye terminal under the nut of the battery terminal clamping bolt.
- Connect both of the black wires (BLK and BLK-WHT) to the negative (-) terminal of the battery in the same way.
- Secure all loom wiring with cable ties along its entire path, as vibration could cause wear to the insulation over time which could result in a dangerous electrical short.

4 Mounting & Connecting the Electrical System

4.3.2 Power Connection to a 24V Vehicle / System

NOTE : Vehicles equipped with aftermarket 'dual battery kits' are not classified as 24V systems. They require the 12 volt compressor kit, and connection to the primary battery only according to section 4.3.1.

- Identify which battery in the system will be used as the 24V negative (-) terminal (i.e., Battery #1 in the wiring diagram Fig. 9.) by connecting a multimeter across the positive (+) terminal of one battery to the negative (-) terminal of the other battery. If you have tested the correct negative (-) terminal then you will read approximately 24 volts on the multimeter, and this battery will be battery #1, and the other battery with the positive (+) terminal you have just tested will be battery #2 (refer to wiring diagram Fig. 9.).

NOTE : If you have tested the wrong negative (-) terminal then you will read approximately 0 volts. Re-test using the opposite batteries.

- Trim the heavy gage black wire that is marked with a white stripe (BLK-WHT) for connection to battery #1 (identified above).

NOTE : If any of the wires require extra length to reach the battery then splice in an extension using ONLY wire that is of the same gage or bigger than the wire being lengthened.

- Trim the RED wire and the lighter gage solid black wire with no stripe (BLK) for connection to battery #2.

NOTE : The inline fuses should be located as close to the battery connection as possible. Never eliminate any fuses when shortening the red wire, and only ever lengthen the red wire on the opposite side of the fuse to the battery.

- Crimp suitable gage automotive eye terminals (not supplied) onto each of the heavy gage (5mm² [10AWG]) RED wires.
- Crimp a suitable gage automotive eye terminal (not supplied) onto the heavy gage (8mm² [8AWG]) BLK-WHT wire.
- Crimp the red eye terminal (supplied) onto one end of the mini-blade fuse holder (supplied). Then crimp the red insulated cable joiner (supplied) onto the other end.
- Now join the mini-blade fuse holder onto the lighter gage black wire (BLK) by crimping the other end of the insulated cable joiner.
- Connect the BLK-WHT wire to the negative (-) terminal of battery #1 by securing the eye terminal under the nut of the clamping bolt.
- Connect the mini-blade fuse holder to the negative (-) terminal of the battery #2 in the same way.
- Connect the RED wire to the positive (+) terminal of the battery #2 in the same way.

NOTE : Double check that the connections match the wiring diagram (Fig 9.). Accidentally reversing the 2 black wires will cause damage to the compressor kit.

- Secure all loom wiring with cable ties along its entire path, as vibration could cause wear to the insulation over time which could result in a dangerous electrical short.

5 Testing & Troubleshooting

5.1 Leak Testing

- With the vehicle parked and the engine off, turn the compressor on and wait until the air system is fully charged.
- The compressor should not come on again for a period of at least 15min. Air system recharging within that time period would indicate that a leak is present in the system.
- If a leak is found to be present, spray a soap and water mixture onto all air fittings in the system while the compressor is fully charged. Bubbles should appear at any leak points.
- Check that leaky fittings have been adequately tightened.
- If leaking persists then disassemble fittings, clean threads, and reapply thread sealant / tape.

5.2 Testing the Air Locker Actuation (Air Locker Systems Only)

To test that the air system, electrical system, and the *Air Locker* differential is functioning correctly:

- Support the vehicle such that the wheels are free to rotate (e.g., on axle stands, a chassis hoist, etc.)
- Leave the parking brake off, the transmission in neutral, and the *Air Locker* switch 'OFF'.
- Turn the ignition to the 'ON' position (leaving the motor off). The large symbol on the *Air Locker* switch cover should not be illuminated.
- Turn the compressor on to charge the air supply to maximum pressure.
- While supporting the drive shaft flange, rotate one wheel by hand.
- The wheel should rotate freely and the opposite wheel should be turning in the opposite direction without any resistance or mechanical noise from within the differential.
- Turn the *Air Locker* switch to the 'ON' position. The symbol on the switch cover should light up.
- Rotate the same wheel again and check that both wheels rotate together.
- Turn the switch off again.
- Rotate the same wheel again.
- The wheels should again rotate in opposite directions.

5 Testing & Troubleshooting

5.3 Electrical Fault Diagnosis

The following describes an effective procedure for tracing an electrical fault in a CKMTA12 or CKMTA24 compressor which has been wired using a genuine ARB wiring loom (refer to the diagram in Figure 9.). All steps must be performed in the order listed here for an accurate assessment.

NOTE : Before attempting to troubleshoot a malfunctioning compressor, always make sure that the compressor manifold, air tanks and connected accessories have been de-pressurized, all connections have been made according to the wiring diagram, the vehicle's ignition is in the ACC power position, and that the ISOLATING SWITCH has been turned 'ON'.

NOTE : The 'MOTOR VOLTAGE' referred to below should be approximately 12V in the case of the CKMTA12 and 24V in the case of the CKMTA24. Otherwise '12V' refers to approximately 12V regardless of compressor model as the 24V compressor runs on a 12V control circuit.

NOTE : Battery number references (e.g., [#1]) are for 24V system wiring purposes.

STEP

1

Using a multimeter, check the voltage at the battery terminals to make sure the battery is working and is fully charged. Check each individual 12V battery in a 24V system.

Did each battery measure at least 12.5 volts?

YES Proceed to STEP 2.

NO Insufficient battery voltage. Recharge or replace the battery.

2

Disconnect the compressor motors from the wiring loom at the connector plugs. Run a new wire directly from the negative (-) terminal of the battery [#1] to the BLK-WHT wire of the one compressor motor. Momentarily connect a wire from the positive terminal of the battery [#2] to the RED wire of the same compressor motor. Repeat for the second motor.

Did the compressor activate when the wires were connected?

YES Remove the extra wires and reconnect the compressor motors. Proceed to STEP 3.

NO Internal compressor motor problem. Contact ARB for assistance.

3

Remove the fuses from the fuse holders in the compressor wiring loom. Using a multimeter, check the continuity (resistance) across the 2 contacts of the fuses.

Did the resistance measure less than 1 Ohm?

YES Proceed to STEP 4.

NO Blown fuse. Replace with a new fuse of same type. Insert new fuse with caution in case a wiring short was responsible for the fuse blowing.

4

Using a multimeter, check for MOTOR VOLTAGE between a chassis ground and each of the two contacts in each of the Maxi-blade fuse holders.

Was MOTOR VOLTAGE detected at one of the two contacts?

YES Reconnect the fuse into the fuse holder. Proceed to STEP 5.

NO Wiring fault between the positive (+) battery terminal and the fuse holder. Check the wire connection at the battery terminal and/or replace the wiring and/or fuse holder.

5 Testing & Troubleshooting

STEP

5

[24V COMPRESSOR AND WIRING ONLY] Using a multimeter, check for 12V between a chassis ground and each of the two contacts in the mini-blade fuse holder.

Was 12V detected at one of the two contacts?

YES Reconnect the fuse into the holder. Proceed to STEP 6.

NO Wiring fault between the negative (-) terminal of the battery [#2] and the fuse holder, Check the wire connection at the battery terminal and/or replace the wiring and /or fuse holder.

6

Remove the compressor cover as shown in Section 2.2. Using a multimeter, check for MOTOR VOLTAGE between a chassis ground and the RED wire at each of the relay blocks (i.e., the wire leading directly from the fuse).

Was MOTOR VOLTAGE detected?

YES Proceed to STEP 7.

NO Wiring fault between the fuse and the relay. Replace wiring and/or fuse holder.

7

Using a multimeter, check for approximately 12V between the negative (-) terminal of the battery [#2] and the RED-YEL wire connected to terminal #2 of the compressor isolating switch. (i.e., the wire leading from the vehicle's ACC power.)

Was 12V detected?

YES Proceed to STEP 8.

NO Wire has not been connected correctly or accessory power has not been turned on. Attach RED-YEL wire to live ACC power.

8

Using a multimeter, check for approximately 12V between the negative (-) terminal of the battery [#2] and the RED wire connected to terminal #3 of the compressor isolating switch. Test while spade terminals are still connected.

Was 12V detected?

YES Proceed to STEP 9.

NO Switch fault or switch not turned 'ON'. Replace switch or toggle switch to 'ON' position.

9

Using a multimeter, check for approximately 12V between the negative (-) terminal of the battery [#2] and the PUR wire connected to the pressure switch attached to the compressor manifold.

Was 12V detected?

YES Proceed to STEP 10.

NO Wiring fault between the isolating switch and the pressure switch. Replace wiring.

10

Using a multimeter, check for approximately 12V between the negative (-) terminal of the battery [#2] and the YEL wire connected to the pressure switch attached to the compressor manifold. Test while spade terminals are still connected.

Was 12V detected?

YES Proceed to STEP 11.

NO Pressure switch fault or tank not de-pressurized. Replace pressure switch or drain tank.

5 Testing & Troubleshooting

STEP

11

Using a multimeter, check for approximately 12V between the negative (-) terminal of the battery [#2] and the YEL wire at each of the relay blocks. (i.e., the wire leading directly from the pressure switch)

Was 12V detected?

YES Proceed to STEP 12.

NO Wiring fault between pressure switch and relay block. Replace wiring.

12

Disconnect the relay from the relay block. Using a multimeter, check the continuity between the BLK wire at the relay block and the negative (-) terminal of the battery [#2].

Did the resistance measure less than 1 Ohm?

YES Reconnect the relay to the relay block. Proceed to STEP 13.

NO Wiring fault in the ground wire between the battery and the relay block. Replace wiring.

13

Using a multimeter, check for MOTOR VOLTAGE between the negative (-) terminal of the battery [#1] and the RED-WHT wire connected to the relay block and while the relay is still connected. Pierce the RED-WHT wire with the multimeter probe to make connection if necessary.

Was MOTOR VOLTAGE detected?

YES Proceed to STEP 14.

NO Relay fault. Replace with a new 12V - 40A relay of the same type.

14

Disconnect the compressor motors from the wiring loom at the connector plug. Using a multimeter, check for MOTOR VOLTAGE between the negative (-) terminal of the battery [#1] and the RED-WHT wire on the loom side of the plug.

Was MOTOR VOLTAGE detected?

YES Proceed to STEP 15.

NO Wiring fault between the relay and the compressor motor connector. Replace wiring.

15

Using a multimeter, check the continuity (resistance) between the each of the BLK-WHT wire on the loom side of the plug (not on the compressor side) and the negative (-) terminal of the battery [#1].

Did the resistance measure less than 1 Ohm?

YES Intermittent wiring fault or internal compressor problem. Contact ARB.

NO Wiring fault in the ground wire between the battery [#1] and the compressor motor. Replace wiring.

5 Testing & Troubleshooting

5.4 Post-Installation Check List

Now that the compressor installation has been completed, ARB recommends that you take the time to complete the following check list just to ensure that you haven't missed any of the vital steps.

- The air system has been leak tested.
- The air filter position will not be exposed to moisture, dust or dirt.
- All air lines and wiring have been securely cable tied to resist snagging.
- Switch(es) have been securely mounted within operator reach, yet well away from danger of accidental engagement.
- Switch(es) function properly and illuminate to indicate activation.

For warranty and service purposes, please fill in the following fields and supply a copy to the customer (if applicable).

ARB PRODUCT MODEL NUMBER: _____

SERIAL No: _____

POINT OF SALE (NAME/LOCATION): _____

DATE OF PURCHASE: _____

INSTALLATION PERFORMED BY: _____

DATE OF INSTALLATION: _____

VEHICLE MAKE: _____

VEHICLE MODEL: _____

VEHICLE YEAR OF MANUFACTURE: _____



6 Parts List

**CKMTA12 &
CKMTA24**

Air Compressor – Exploded Parts Diagram

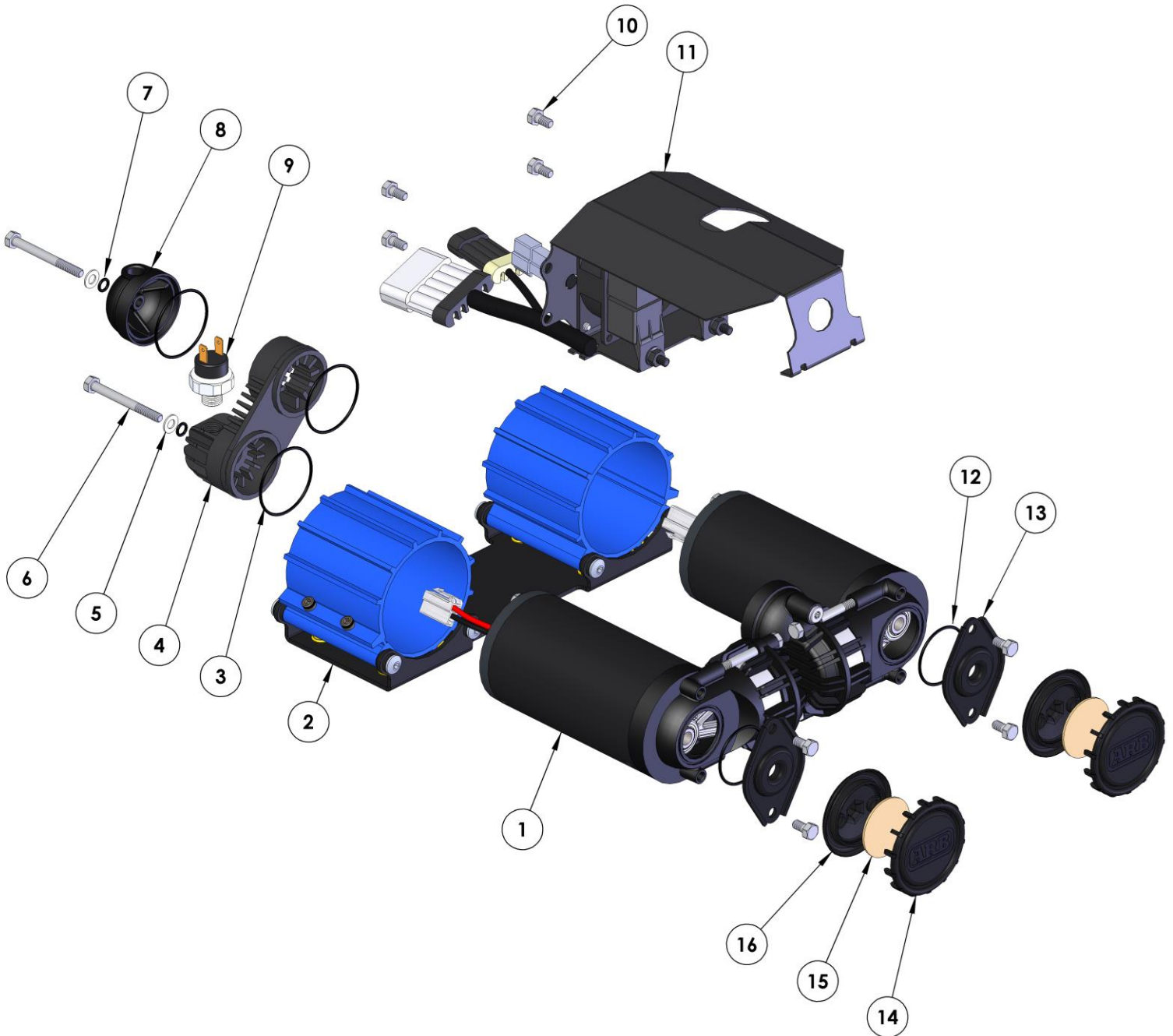

6 Parts List

CKMTA12 & CKMTA24 Air Compressor

ITEM #	QTY	DESCRIPTION	PART #	NOTES
01(a)	2	COMPRESSOR ASSEMBLY (12V)	CKM01	1
01(b)	2	COMPRESSOR ASSEMBLY (24V)	CKM02	1
02	1	TWIN COMPRESSOR MOUNT ASSEMBLY	320108	
03	3	O-RING (BS031N70)	160241	2
04	1	COUPLER MANIFOLD	320227	
05	2	FLAT WASHER (M6)	6151046	
06	2	MANIFOLD BOLT (M6 x 60mm)	200716	
07	2	O-RING (METRIC 6 x 2 N70)	160242	
08	1	MANIFOLD CAP	320214	
09	1	PRESSURE SWITCH (1/4" NPT)	180901	
10	8	HEX BOLT (M6 x 12mm)	200702	
11	1	COVER ASSEMBLY, CKMT	320110	
12	2	O-RING (BS029N70)	160250	2
13	2	AIR FILTER FLANGE (1/4" NPT)	320212	
14	2	AIR FILTER COVER	320501A	3
15	2	AIR FILTER ELEMENT (DISK TYPE)	290503	3
16	2	AIR FILTER BASE	320501B	3
*	4	HEX BOLT (M6 X 20mm)	6151213	
*	4	FLAT WASHER (M6)	200709	
*	4	SPRING WASHER (M6)	4581287	
*	1	WIRING LOOM SUPPLY (CKMTA12 / 24)	180414	4
*	1	WIRING LOOM SWITCH (CKMTA12 / 24)	180415	4
*	2	RELAY, SEALED (12V, 40A)	180905	
*	1	SWITCH COMPRESSOR	180222	
*	2	FUSE, 40A, MAXI TYPE	180703	
*	1	MINI BLADE FUSE HOLDER, 5A FUSE	180418	5
*	1	EYE TERMINAL, 8MM (RED)	180707	5
*	1	CABLE JOINER, INSULATED (RED)	180708	5
*	1	INSTALLATION GUIDE, CKMA	2102MTA12	

Available separately or included with Air Locker kits.

* Not illustrated in exploded view.

Specs:

Voltage	12 Volts (CKMTA12), 24 Volts (CKMTA24)
Current Draw	No-Load 28A (CKMTA12 only) Load 50A (CKMTA12 only)
Air Flow	174.3L/min @ 0Bar [6.16CFM @ 0psi] 131.7L/min @ 2Bar [4.65CFM @ 29psi]
Total Weight	8.8kg [19.4lbs]
Size	102mm x 190mm x 275mm (H,L,W) [4.0" x 7.5" x 10.8"]
Outlet Port	1/4" NPT
Pressure Switch	Open 10.3Bar [150psi]
Pressure Switch	Closed 9.3Bar [135psi]
Safety Valve	OPEN @ > ~12.4 [180 PSI]

Notes:

- Motor voltage is the only difference between The CKMAT12 and CKMTA24 compressors. CKM motors are serviceable. Contact ARB.
- Complete set of O-ring seals is also available as O-ring Service Kit #320301.
- AIR FILTER COVER (14) & BASE (16) available only in AIR FILTER ASSY #320501 which also includes the element.
- Wiring looms set of #180414 & #180415 suits both 12 & 24 volt systems. See full wiring diagram attached.
- Only included in the CKMTA24

