

CONTROLLED DRAWING

REVISIONS				
REV.	DESCRIPTION	BY	DATE	ECN No.
A	NEW TEMPLATE	JS	05/02/2021	
B	INSTRUCTION CLARIFICATION	JS	8/11/2022	22-370

PRINT AT 1:1 SCALE.

CONFIRM TEMPLATE IS TO CORRECT SCALE USING A RULE TO CHECK DIMENSIONS LISTED ON THIS TEMPLATE BEFORE CUTTING

ALIGN THIS TEMPLATE TO VEHICLE AS SHOWN IN THE FITTING INSTRUCTIONS.

MARK THE CUT ON THE RHS OF THE BUMPER THEN REVERSE THIS TEMPLATE AND MARK ON THE LHS.

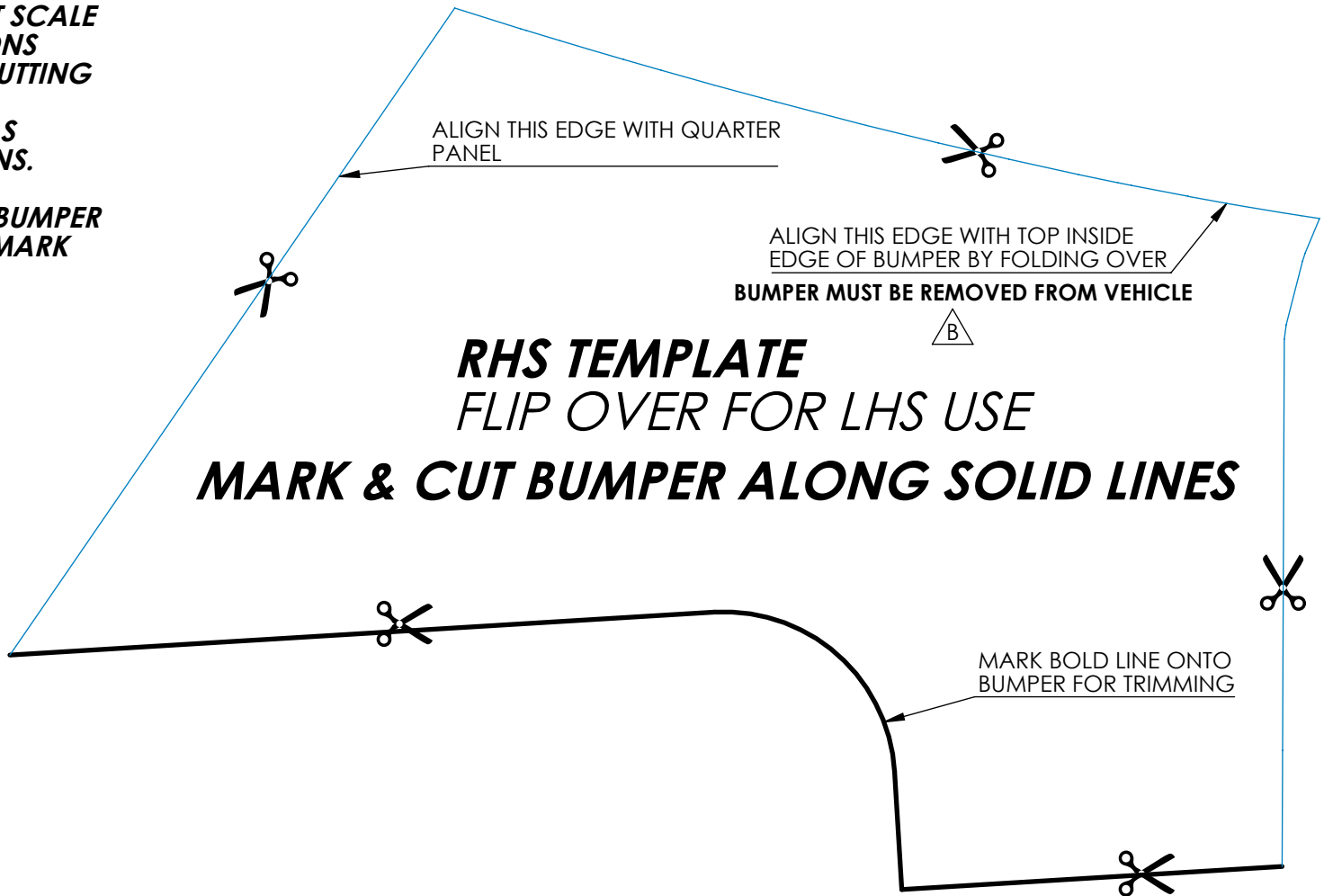
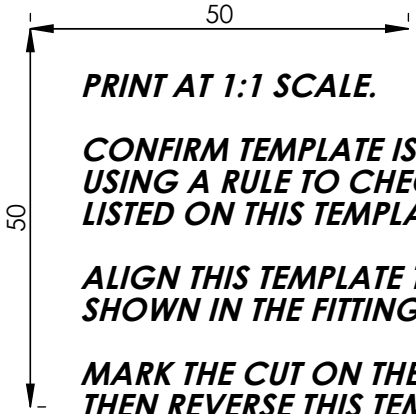

<small>PROPRIETARY & CONFIDENTIAL © COPYRIGHT</small> <small>ALL RIGHTS RESERVED. THIS DRAWING MUST NOT BE COPIED OR USED FOR ANY PURPOSE WITHOUT THE EXPRESS AUTHORITY OF ARB CORPORATION LIMITED.</small>		ARB Corporation Ltd		TITLE: CUTTING TEMPLATE 3448590	
DO NOT SCALE ALL DIMENSIONS IN MILLIMETERS		<small>GENERAL MATERIALS AND FINISH REQUIREMENTS REFER TO S01-069</small>		MATERIAL: PAPER	
ANGULAR TOL. X° ± 1° X.X° ± 0.5°		LINEAR TOL. X ± 1.0 X.X ± 0.5		MASS (kg): 0.0	
REMOVE ALL BURRS, FLASH & SHARP EDGES		 THIRD ANGLE PROJECTION SCALE 1:1 SIZE A4		FINISH: NATURAL	
		DETAILED J STUBBE CHECKED J STUBBE		DATE 29/01/2021 DATE 8/11/2022	
				PART NO.: 37800118	
				PAGE 1 OF 1 REV. B	