



FITTING INSTRUCTIONS

Part Number: **3414770**

Description: **TOYOTA HILUX SUMMIT MKII BULLBAR**

Suited to vehicle/s: **TOYOTA HILUX 26+
WORKMATE, SR AND SR5 MODELS**

Optional Fitting Kits: **3514210– WINCH FIT KIT
3500605 – HAWSE SPACER KIT NARROW**

WARNING

REGARDING VEHICLES EQUIPPED WITH SRS AIRBAG:

When installed in accordance with these instructions, the front protection bar does not affect operation of the SRS airbag.

ALSO, NOTE THE FOLLOWING:

- ◆ This product must be installed exactly as per these instructions using only the hardware supplied.
- ◆ In the event of damage to any bull bar component, contact your nearest authorised ARB stockist. Repairs or modifications to the impact absorption system must not be attempted.
- ◆ Do not use this product for any vehicle make or model, other than those specified by ARB.
- ◆ Do not remove labels from this bull bar.
- ◆ This product or its fixing must not be modified in any way.
- ◆ The installation of this product may require the use of specialized tools and/or techniques.
- ◆ It is recommended that this product is only installed by trained personnel.
- ◆ These instructions are correct as at the publication date. ARB Corporation Ltd. cannot be held responsible for the impact of any changes subsequently made by the vehicle manufacturer.
- ◆ During installation, it is the duty of the installer to check correct operation/clearances of all components.
- ◆ Work safely at all times.
- ◆ Unless otherwise instructed, tighten fasteners to specified torque.

ARB 4x4 ACCESSORIES

Corporate Head Office

42-44 Garden St
Kilsyth, Victoria
AUSTRALIA, 3137

Tel: +61 (3) 9761 6622
Fax: +61 (3) 9761 6807

Australian enquiries
North & South American enquiries
Other international enquiries

sales@arb.com.au
sales@arbusa.com
exports@arb.com.au

www.arb.com.au

GENERAL CARE AND MAINTENANCE

By choosing an ARB Bar, you have bought a product that is one of the most sought after 4WD products in the world. Your bar is a properly engineered, reliable, quality accessory that represents excellent value. To keep your bar in original condition it is important to care and maintain it following these recommendations:



- Prior to exposure to the weather your bar should be treated to a Carnauba based polish on all exposed surfaces. It is recommended that this is performed on a six monthly basis or following exposure to salt, mud, sand or other contaminants.
- As part of any Pre Trip Preparation, or on an annual basis, it is recommended that a thorough visual inspection of the bar is carried out, making sure that all bolts and other components are torqued to the correct specification. Also check that all wiring sheaths, connectors, and fittings are free of damage. Replace any components as necessary. This service can be performed by your local authorized ARB Stockist.

FITTING REQUIREMENTS

REQUIRED TOOLS FOR FITMENT OF PRODUCT:

BASIC TOOL KIT	ELECTRIC DRILL WITH COMPLETE METRIC DRILL SET
JIG SAW OR OSCILATING MULTITOOl WITH BLADE SUITABLE FOR PLASTIC	LOW TACK MASKING TAPE
FILE	UTILITY KNIFE
TAPE MEASURE	CLAMP
STEEL RULE	WHITE FELT MARKER
HACK SAW	TORQUE WRENCH
TOUCH UP PAINT ANTI CORROSION	RIGHT ANGLE ELECTRIC DRILL

HAVE AVAILABLE THESE SAFETY ITEMS WHEN FITTING PRODUCT:

Protective eyewear		Hearing protection	
--------------------	---	--------------------	---

NOTE: 'WARNING' notes in the fitting procedure relate to OHS situations, where to avoid a potentially hazardous situation it is suggested that protective safety gear be worn or a safe work procedure be employed. If these notes and warnings are not heeded, injury may result.

FASTENER TORQUE SETTINGS:

SIZE	Torque Nm	Torque lbft
M6	9Nm	7lbft
M8	22Nm	16lbft
M10	44Nm	32lbft
M12	77Nm	57lbft

PARTS LISTING

APPLICATION.	PART NO.	QTY	DESCRIPTION
MOUNTS TO VEHICLE	3759666L	1	BRKT CHASSIS IN HILUX 15ON LHS
	3759666R	1	BRKT CHASSIS IN HILUX 15ON RHS
	37501190L	1	CHASSIS BRKT OUTER LHS HILUX
	37501190R	1	CHASSIS BRKT OUTER RHS HILUX
	4584363	8	WASHER FLAT M12x26x4 HV300 TZP480
	4584399	24	WASHER FLAT M10x25x3 ZNB480
	4584410	8	WASHER FLAT M12x31.75x2.5 BTZP480
	4655863L	1	CHASSIS MOUNT LHS HILUX 26 ON
	4655863R	1	CHASSIS MOUNT RHS HILUX 26 ON
	4722161	2	CRUSH TUBE M12 29.5 O.D
	4722162	2	CRUSH TUBE M12 20 O.D
	6151545	8	BOLT HXHD FL M12x1.25x35 PC8.8 BTZP480
	6151689	4	BOLT HXHD M12x1.25x90 PC10.9 ZP
	6151698	4	BOLT HXHD FL M10x1.25x40 PC8.8 BTZP480
	6151752	16	NUT FLANGE M10x1.5 PC8.8 BTZP480
	6151835	4	NUT HEX NYLOC M12x1.25 PC10.9
	6151965	16	BOLT HXHD FL M10x1.5x30 PC8.8 ZNB480
	6152023	6	NUT FLANGE M12x1.25 PC10.9 ZAB1000
BUFFERS & MOULDINGS	3163290	1	GRILLE RDR CVR, SUIT SUMMIT
	3163294	1	KIT, CVR STRAP SUIT SUMMIT
	3163295	1	KIT, GRILLE OUTER SUIT SUMMIT
UNDER PANELS	4584327	16	WASHER FLAT M6x16x1.2 BTZP480
	6151300	6	NUT CAGED M6 2.6-3.5 956-C
	6151443	10	SCREW BHD M6x20 BZP
	6151459	6	SCREW BHD M6x16 BTZP480
	6151526	10	NUT CAGED M6 1.8-2.7 BZP480
	6151655	2	NUT FLANGE M8x1.25 PC8 TZP480 ENS 14/002
	6151730	6	BOLT HXHD FL M8x1.25x20 FT PC8.8 BZP480 ENS14-001
	6523777L	1	UNDER WING PANEL LHS HILUX
	6523777R	1	UNDER WING PANEL RHS HILUX
	6523778	1	CENTRE PANEL HILUX
	6523845	1	REAR UNDERPANEL
WINCH COVER PANEL FITMENT (IF NO WINCH IS FITTED)	4584327	8	WASHER FLAT M6x16x1.2 BTZP480
	6151443	4	SCREW BHD M6x20 BZP
	6151223	4	NUT HEX NYLOC M6x1.0 ZNB480
	6523321	1	PANEL WINCH COVER MB SUIT PXIII
NUMBER PLATE	4584295	2	WASHER FLAT M6x12 BZP
	5848302	2	PACKER RB NYLON
	6151173	2	NUT FLANGE M6 ZNB480 SERRATED
	6151459	2	SCREW BHD M6x16 BTZP480

PARTS LISTING - CONTINUED

LIGHTS & SENSORS	3163222	2	PLUG SNSR BLANKING PAIR
	3500991	1	LAMP CLUSTER, ARB SUMMIT RH&LS LAMP SET
	3501200	1	HARNESS CAN MODULE BULLBAR
	3514190	1	HARNESS CANBUS ADAPTOR HILUX26
	3525010	1	SENSOR SURROUND KIT (4) SUITS LC300
	37500120	1	RADAR BRKT LOWER
	37500121	1	RADAR BRKT UPPER
	37501277	2	LIGHT RETAINER SUIT HILUX
	37501284	1	BRACKET CAMERA RELOCATION
	37501326	1	LOW SPEC CAMERA BRACKET
	4584295	12	WASHER M6x12 BZP
	4584327	4	WASHER FLAT M6x16x1.2 BTZP480
	4584421	2	WASHER FLAT M6x18x1.6 NYLON
	4656068	1	BLANKING BRACKET ASSY
	5670069	2	SPRING COMP STAINLESS 25X6.0ID
	6151173	4	NUT FLANGE M6 ZNB480 SERRATED
	6151223	6	NUT HEX NYLOC M6x1.0 ZNB480
	6151300	2	NUT CAGED M6 2.6-3.5 956-C
	6151443	5	SCREW BHD M6x20 BZP
	6151459	6	SCREW BHD M6x16 BTZP480
	6151584	2	BOLT HXHD M6x1.0x40 PC8.8 BTZP
	6151649	2	SCREW BHD M4x16 SK BTZP480
	6152094	2	SCREW PHD M6x1.0x30 PC8.8 TX ZNB 480
	6821451	2	HARNESS EXTENSION SUITS TOYOTA
	6821656	1	RADAR HARNESS EXTENSION
CANDEC	1	CAN BUS DECODER MODULE INCLUDES WIRING HARNESS	
MISC	180302	8	CABLE TIE 4.8 X 180 MM BLACK
	6191030	2	PINCH WELD 520mm
	6781438	1	TAPE 3M4991-2.3MM VHB 20X25 2PCS
TEMPLATE	37800583	1	TEMPLATE FLARE CUT 3414770

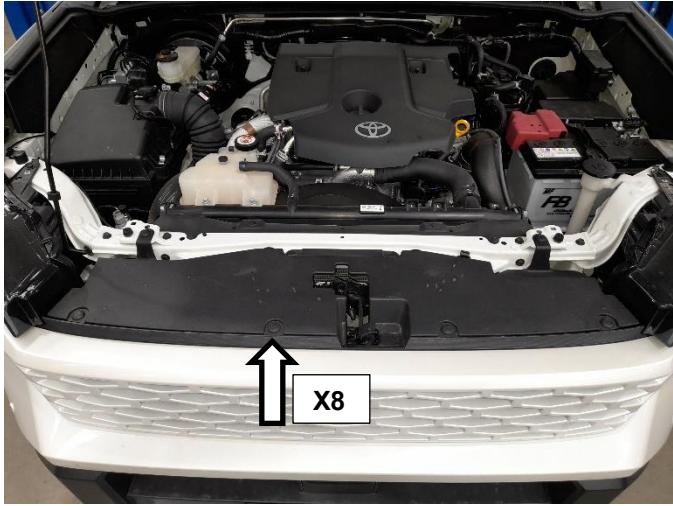

Note: Read the instructions thoroughly before starting.

1. Open the bonnet and remove all scrivets (8) retaining plastic cover. Set aside scrivets removed for re-use later on. Remove plastic cover from above grille and set aside, this will be reused.

TIP: Depress centre to remove.

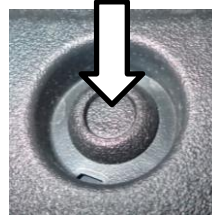

2. Remove all lower fasteners and scrivets retaining bumper along inside edge of wheel arches – (Right hand side shown).

Leave the upper fasteners in place.



3. Remove all fasteners and scrivets retaining bumper along lower lip.

Set aside scrivets and fasteners used to attach bumper to OEM stone deflector for re-use later on.



Remove front mud flaps



Remove screws beneath mud flap.

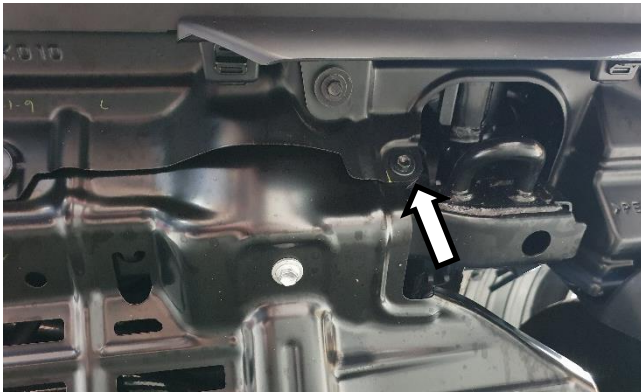

4. Remove bolts as shown



5. Remove dressing piece from underside of bumper and discard.

PROTOTYPE RELEASE ONLY - NOT FOR PRODUCTION

REVISIONS	
REV	DESCRIPTION

PRINT AT 1:1 ON YOUR PRINTER.

CONFIRM TEMPLATE IS TO CORRECT SCALE USING A RULE TO CHECK DIMENSIONS LISTED ON THIS TEMPLATE BEFORE CUTTING

TEMPLATE TO BE USED FOR BOTH SIDES

ALIGN THIS TEMPLATE TO VEHICLE AS SHOWN IN THE FITTING INSTRUCTIONS.

MARK THE CUT ON THE RHS OF THE BUMPER THEN REVERSE THIS TEMPLATE AND MARK ON THE LHS.

MARK & CUT BUMPER ALONG SOLID LINES

**RHS TEMPLATE
FLIP OVER FOR LHS USE**

ALIGN THIS EDGE WITH THE
INDICATED LINE

ALIGN THIS EDGE WITH THE
INDICATED LINE

ALIGN THIS EDGE WITH THE
INDICATED LINE

ALIGN THIS EDGE WITH THE
INDICATED LINE

CONNECT THE EDGE
WITH A 1MM RADIUS

**NOTE: THIS SHEET MUST BE PRINTED
AT 1:1 SCALE.**

**CHECK SCALE
BEFORE CUTTING**

ARBS ARB Corporation Ltd

37800583

37800583

CUTTING TEMPLATE

1 OF 1

1:1

PAPER

37800583

6. Carefully cut out flare/bumper cut template supplied.

7. **Note: Template will be used for both sides (LH & RH) – be careful not to damage.**



8. Stick masking tape onto flare at area underneath headlight running the tape well in towards the centre of the bumper.
9. Position template onto the flare aligning with edges of bumper specified on template.
10. Using a permanent marker, outline edges of bumper cut template onto masking tape where the flare and bumper cut will be performed.

Remove template and repeat for LHS. Take care not to rip template upon removal.

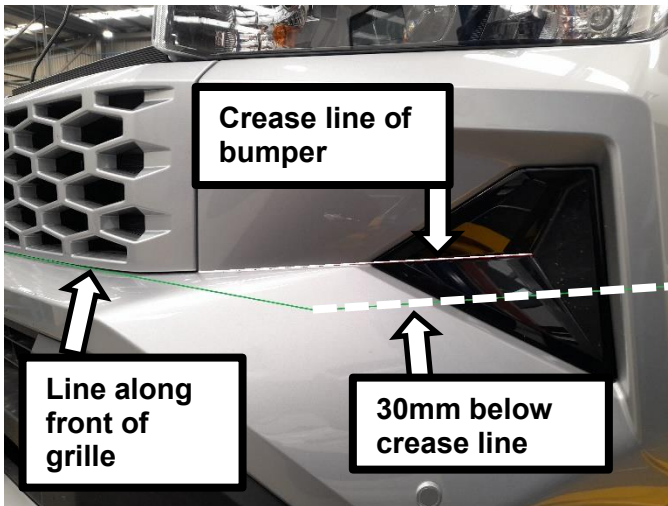

11. Mark a line along the bottom edge of the grille. Extend this line out each side for approx 200mm.

Measure 30mm below the crease line of the bumper and mark a parallel line.

12. Using a ruler draw a continuous straight line from the edge of the cutting template to the line marked in the previous step. The template line will need to be extended down to meet the horizontal line.

Note: A steel rule or tape measure can be used as a guide for marking out.

13. Repeat above for LHS.

14. Final cut line should appear as shown below, connecting to the templated cut on the flares:

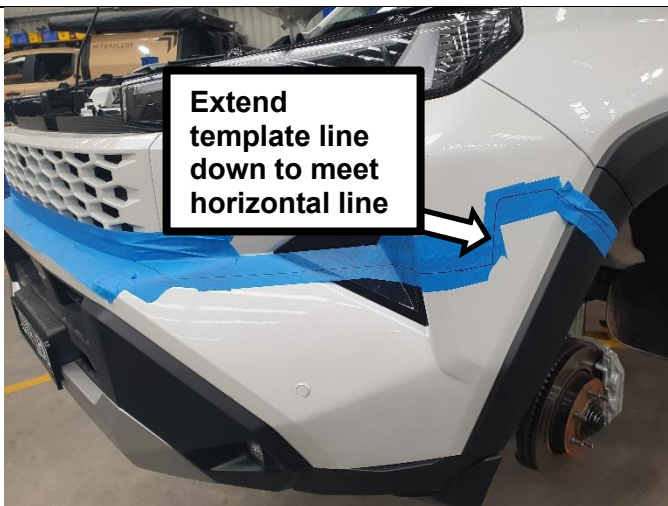



15. Carefully cut bumper along marked lines using an oscillating multitool. Repeat for LHS.

16. Discard lower bumper section after removing sensors/harness. this will not be reused



Warning: Cutting operations can result in flying debris, safety glasses should be worn.

17. Fit Pinch weld to RH side along the cut edge on the flare. Carefully trim off any excess length and use remainder for other side.

Note: 1 full length of pinch weld supplied, 1/2 used on each side of vehicle.



18. Cut carefully on driver's side, so as not to damage the cable as shown. Once the bumper is cut, disconnect the cable.



19. Removed lower section of bumper shown.



20. Using a flat black spray can, paint the exposed body in the area of the wing tips, as shown.



21. Using a paint pen or white marker, label each parking sensor (Inner, outer, left or Right) prior to removing from bumper.

Once marked, unclip parking sensors (2) from bumper and store for reuse.

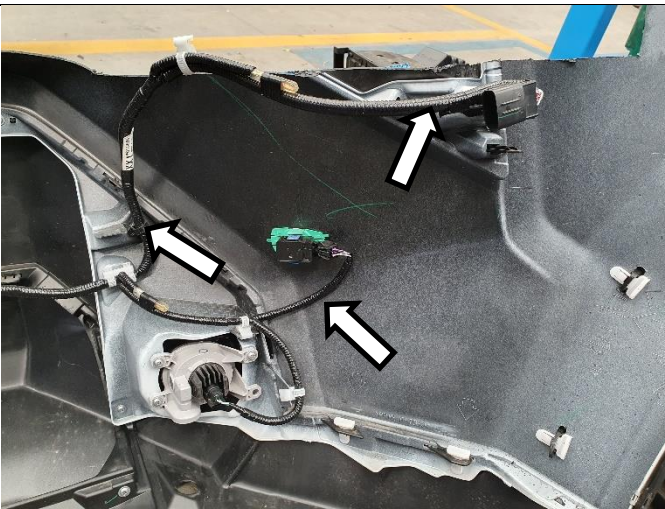

22. Remove harness from the lower bumper section. The fog lights will not be re-used.

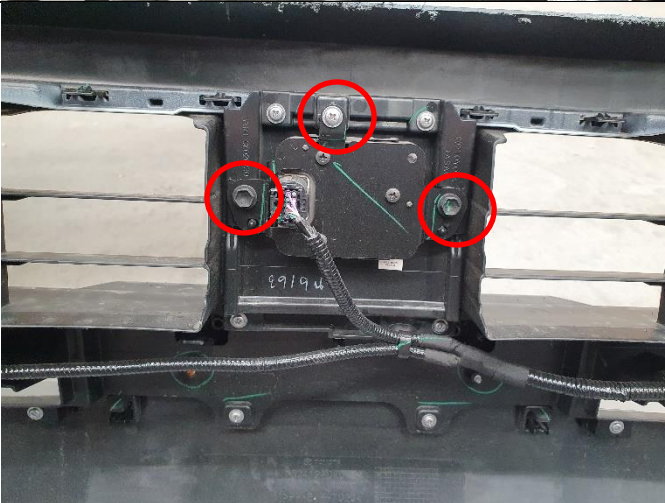

23. Remove the radar module



24. Remove plastic lower crush absorber from vehicle and discard.

Note: Lower crush absorber is retained by plastic clips. Levering absorber free with a large screw driver may aid removal.

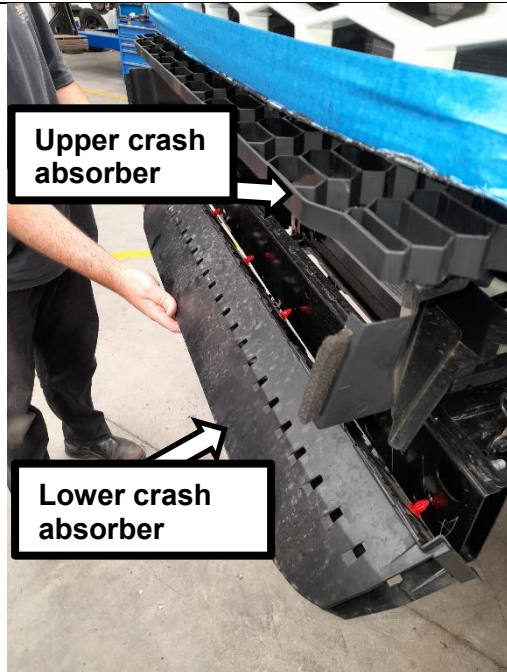

25. Remove bolts securing plastic upper crash absorber from vehicle and discard.

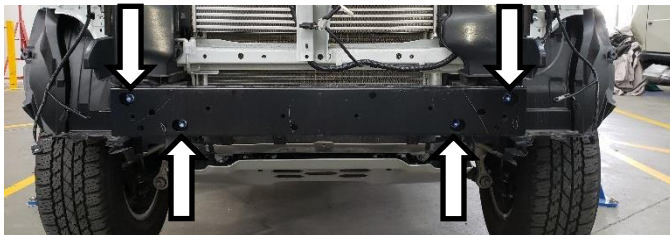

26. Remove two M10 bolts on both sides (4 total) fixing crash beam to chassis and remove crash beam.

Discard crash beam.

Note: Retain four M10 bolts for reuse.

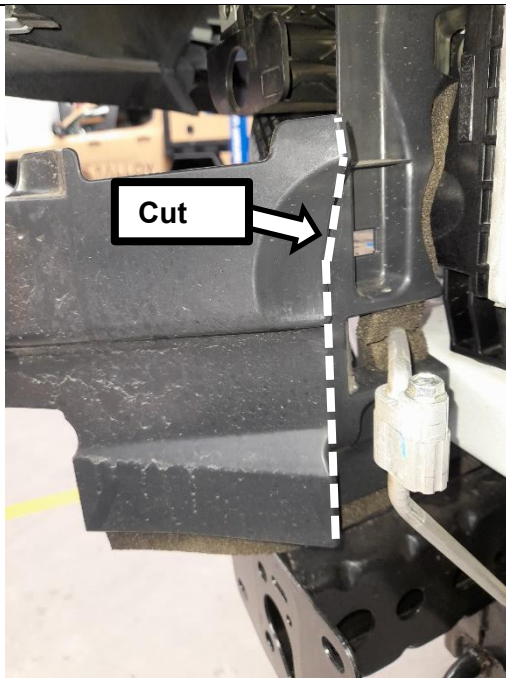

(RHS SHOWN)

27. Locate air deflector panels and mark up as shown. Follow the corners of the panel. (Right Hand side shown).
28. Use an oscillating multitool or shears to carefully cut lower portion away and discard.

Note: Take care not to damage any other components on the vehicle whilst cutting.

29. Carefully remove any burrs or sharp edges with a file and/or sandpaper.

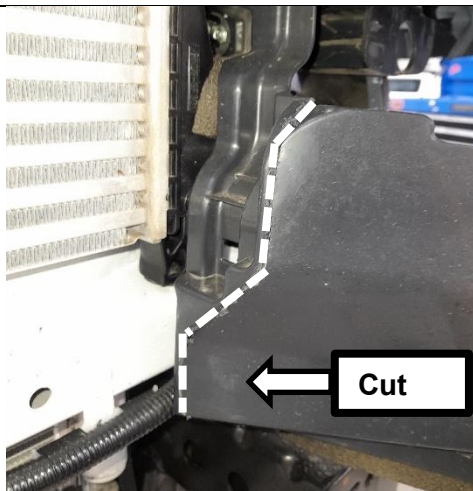

(LHS SHOWN)

30. Repeat for LHS as shown.

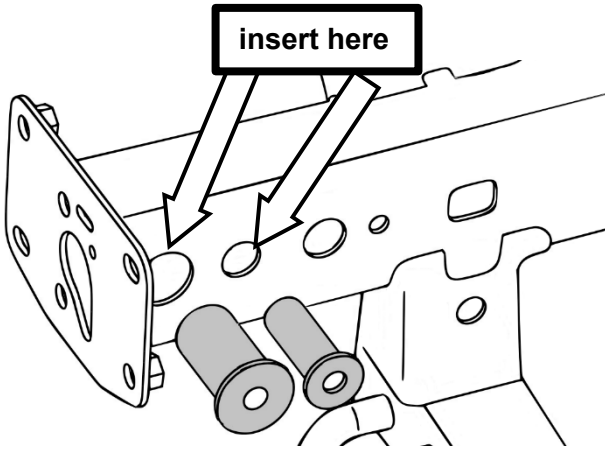
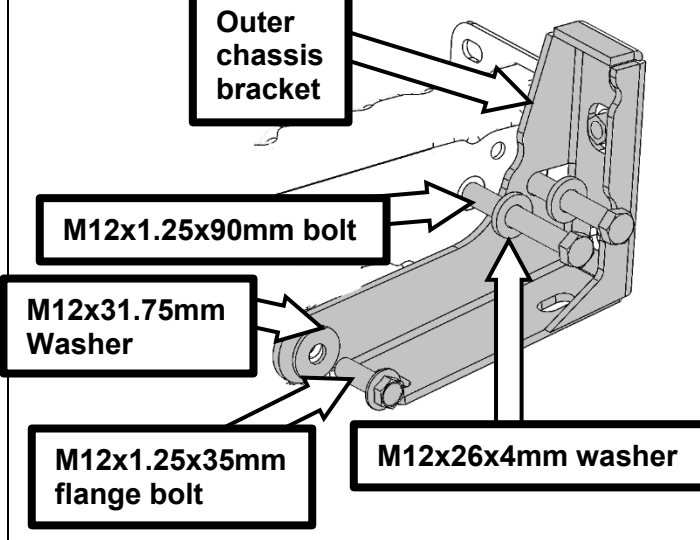
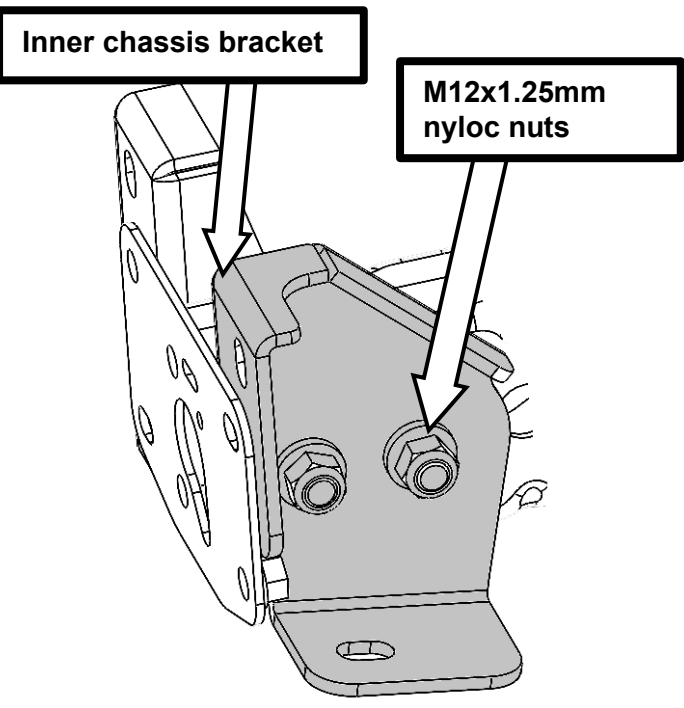

	<p>31. Insert two crush tubes into RHS chassis rail as shown.</p>
	<p>32. Loosely fasten RHS outer chassis support bracket to outside face of chassis using two M12x1.75x90mm flange bolts installed into the previously installed crush tubes.</p> <p>33. Loosely fasten the RHS outer chassis support bracket at the rear hole using one M12x1.25x35 bolt and M12x31.75 flat washer installed into OEM captive nut in the chassis bracing.</p>
	<p>34. Loosely fasten RHS inner chassis support bracket to inside chassis face using two M12x1.25mm nyloc nuts and two M12x26x4 washers</p> <p>35. Repeat process to install chassis support brackets on LHS</p>

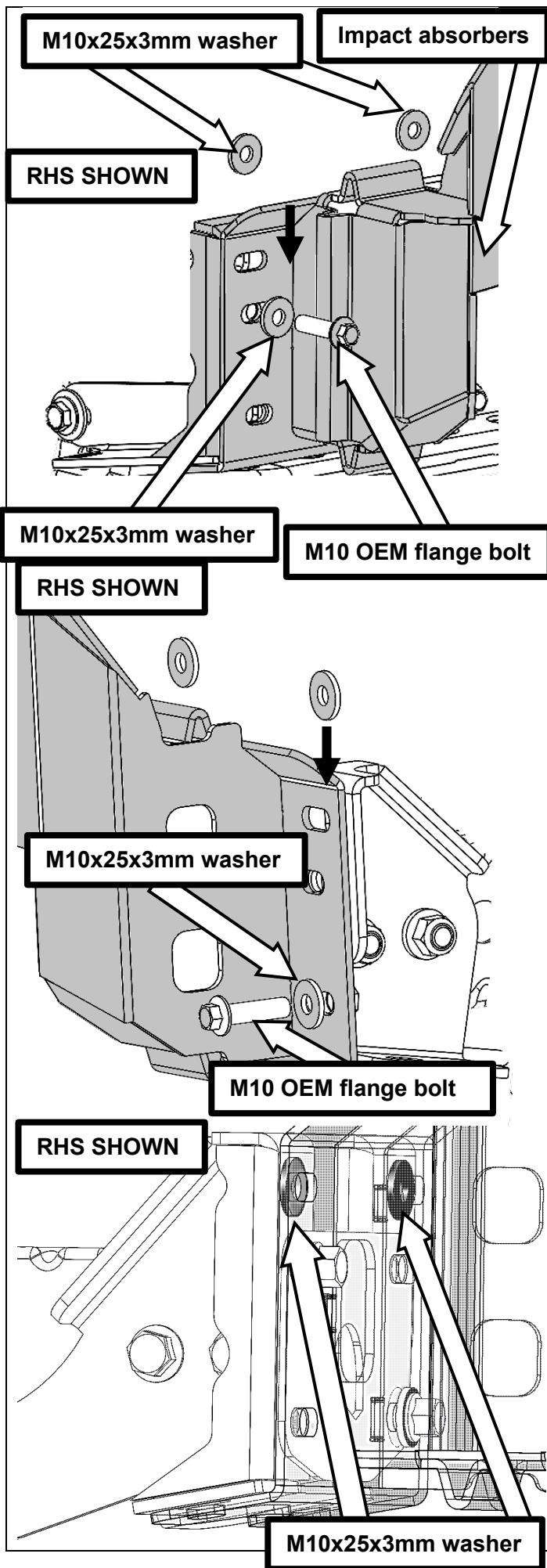

36. Loosely install the bull bar impact absorbers onto vehicle chassis flange by fastening two OEM M10 flange bolts (retained in step 14) and two M10x25x3mm flat washers into the chassis flange captive nuts.

IMPORTANT

37. Ensure two M10x25x3mm flat washers are installed inline with the top impact absorber slots, between the impact absorbers and rear chassis support brackets.

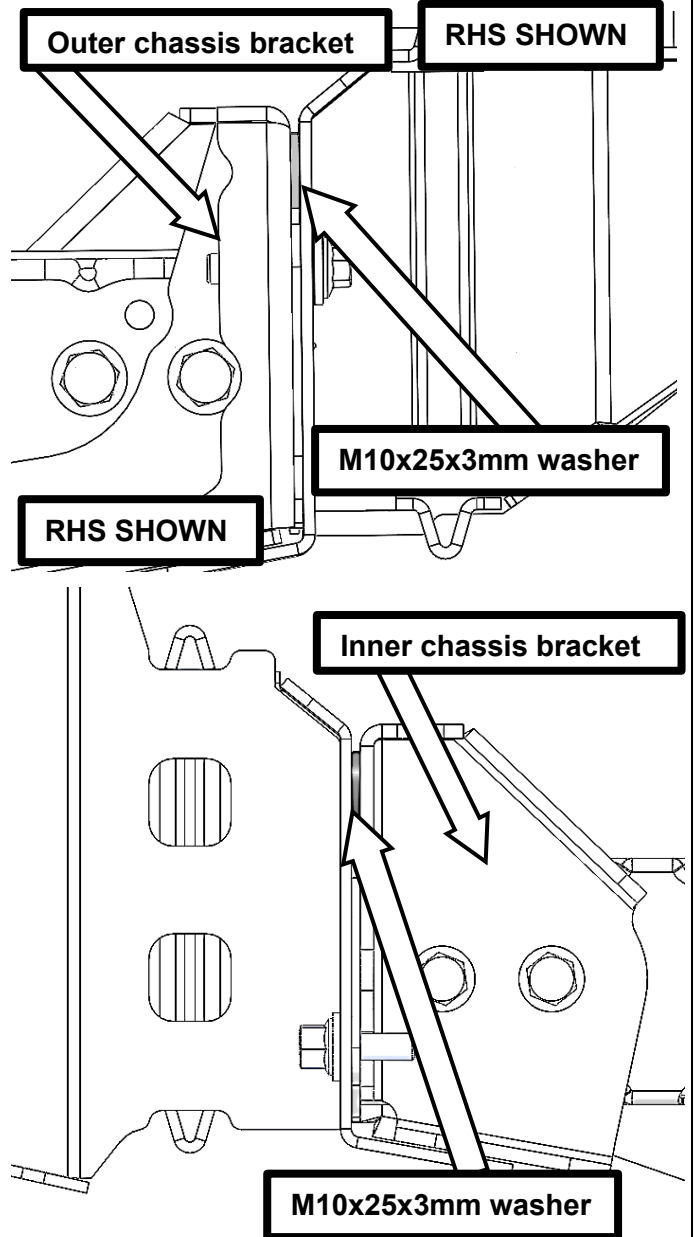

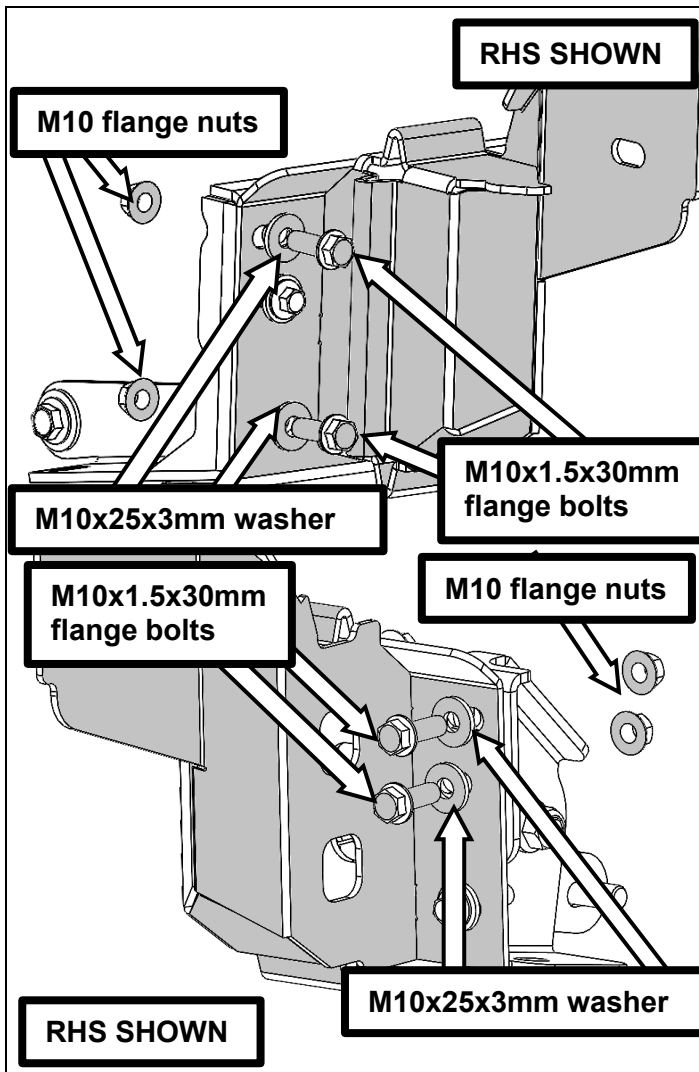

38. Loosely fasten four M10x1.5x30mm flange bolts, M10x25x3mm flat washers, M10 flange nuts through bull bar impact absorbers, chassis flange and rear chassis support brackets.

NOTE: IMPACT ABSORBERS ARE HANDED. RIPPLES ARE ON THE OUTSIDE OF MOUNTS

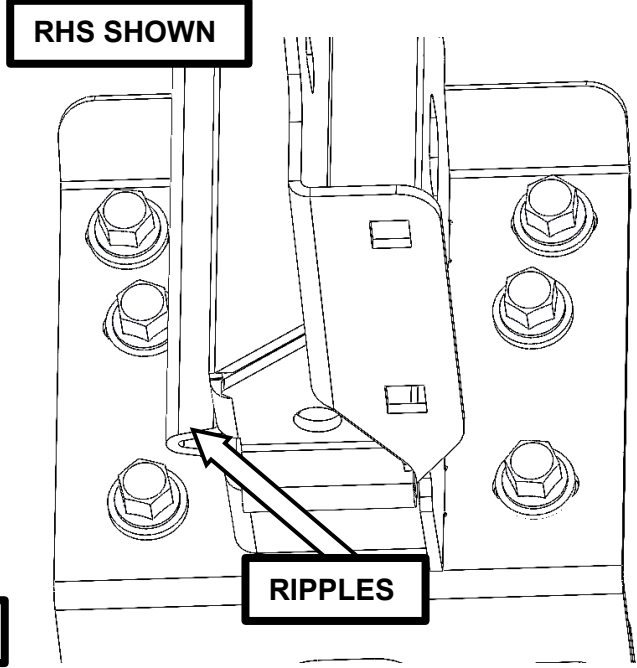

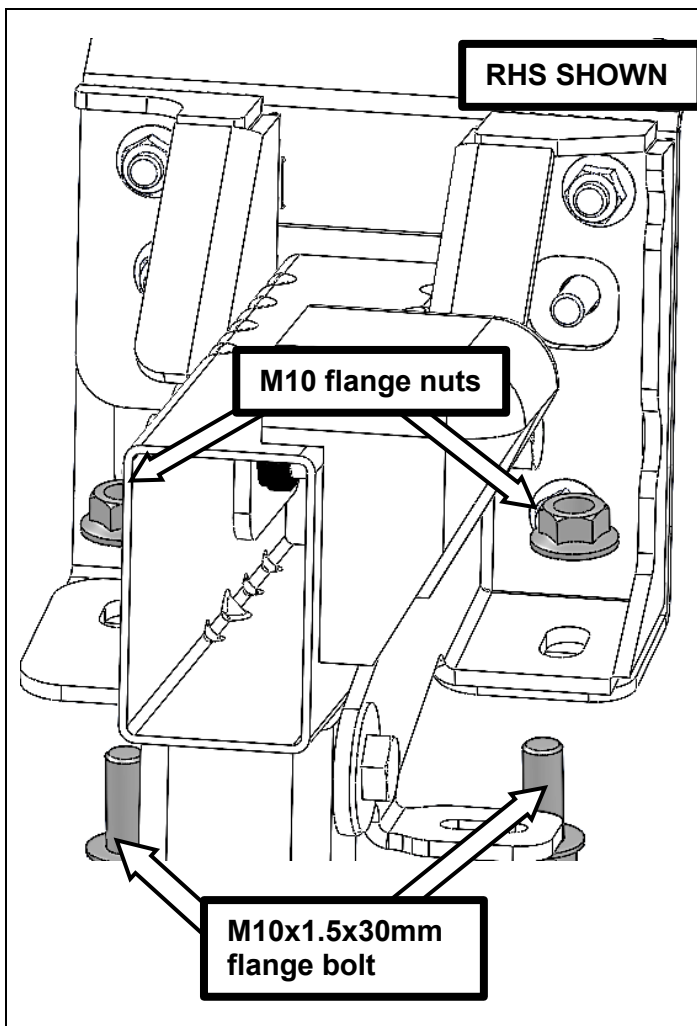

39. Loosely install two M10x30 flange bolts through lower slot of the impact absorbers and chassis support brackets into M10 flange nuts.

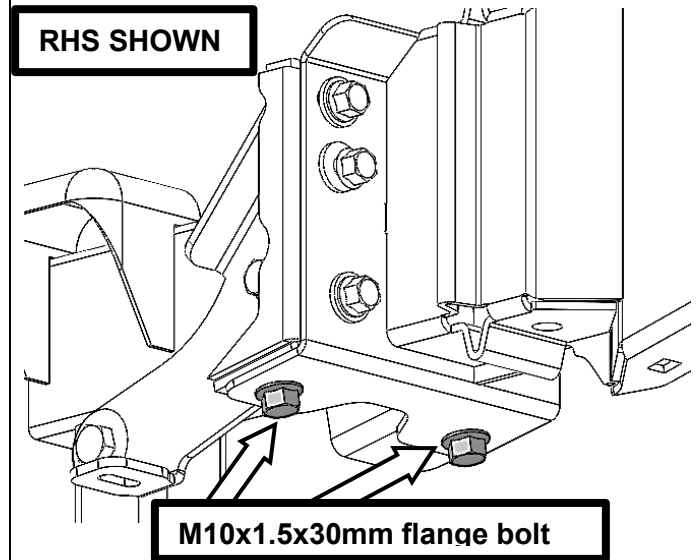

40. Repeat process to install impact absorbers on the LHS.

Note: Starting with the M10 bolts installed from the front of the impact absorber, tighten all fasteners enough to eliminate any play in mount or support brackets but to still allow for adjustment of bull bar.

IF FITTING WINCH REFER TO WINCH FIT KIT 3514210 FITTING INSTRUCTIONS

FITMENT OF WINCH REQUIRES WINCH FIT KIT 3514210

FITMENT OF WINCH WITH SYNTHETIC ROPE MAY REQUIRE (3500605) HAWSE FAIRLEAD SPACER KIT OR OFFSET HAWSE

41. If not fitting a winch, assemble the winch cover panel to the bar using four M6 x 20 button head screws, 16mm flat washers and nyloc nuts.

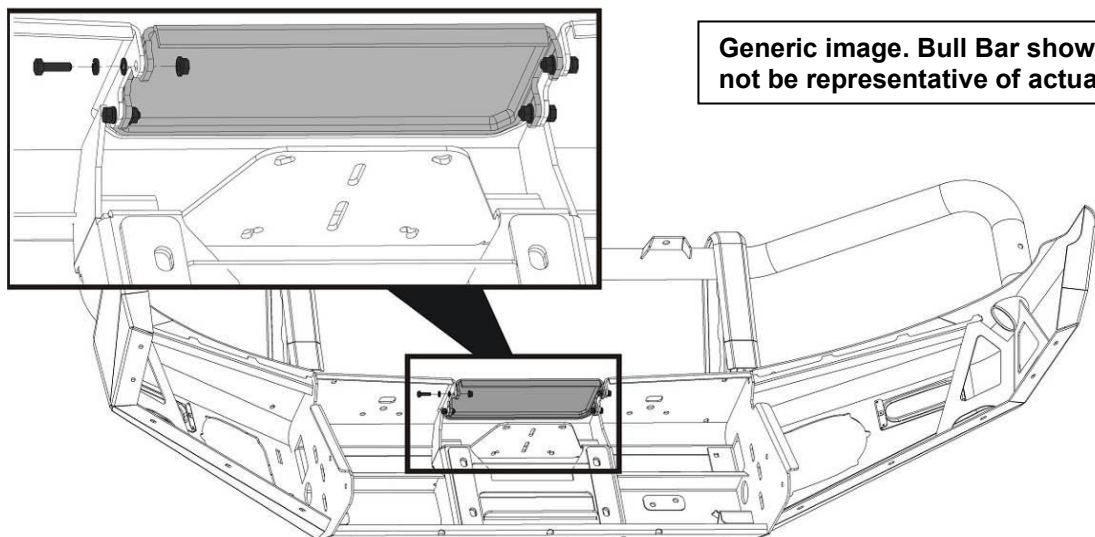

Generic image. Bull Bar shown may not be representative of actual product.

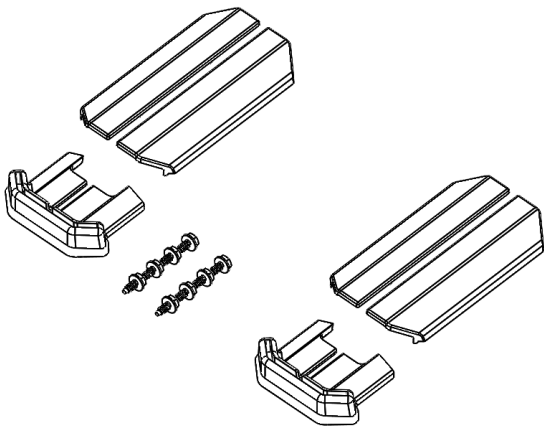

42. Identify the cover strap plastics kit, 3163294.

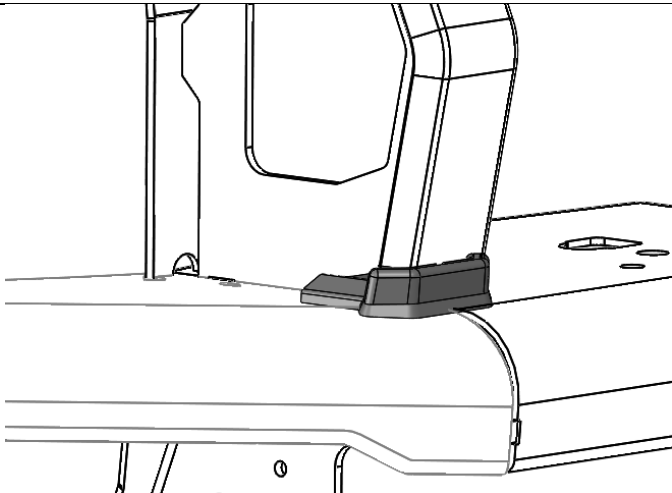

43. Fit the rubber intersection mouldings to the base of each upright cover strap.

Ensure that the skirt of the rubber moulding is not folded back on itself and is sitting flat against the bull bar.

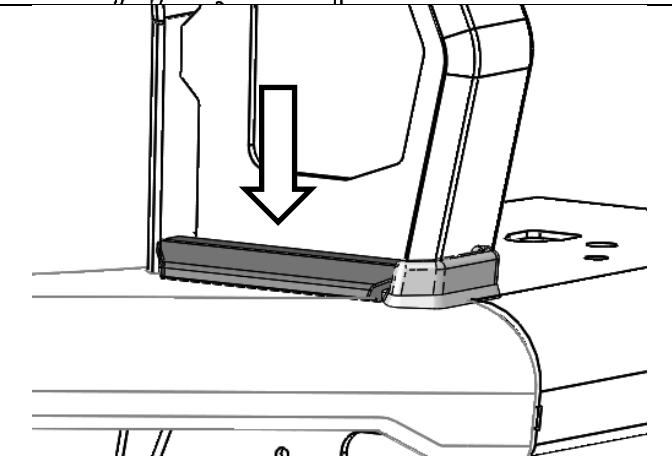

44. Place the plastic cover down onto the rubber moulding, repeat on both sides of the cover straps.

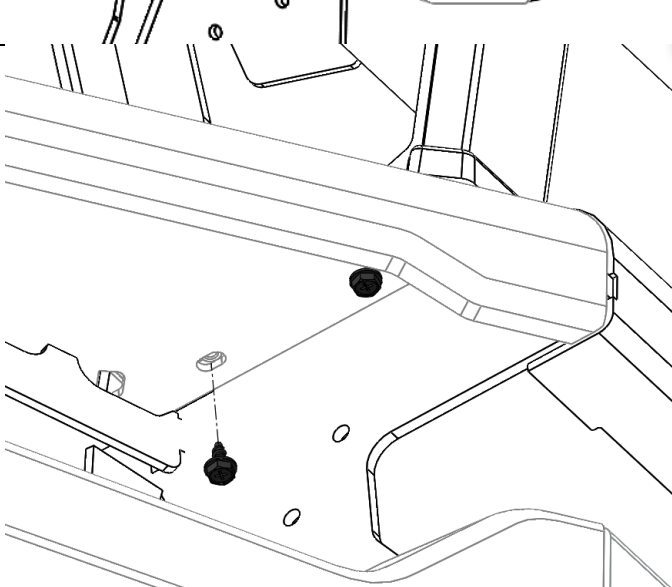

45. From underneath, fit two screws into each plastic cover. Tighten until the covers are secure and have firmly clamped the rubber moulding.

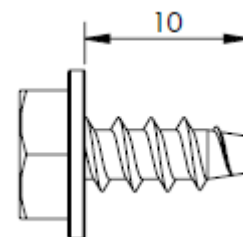

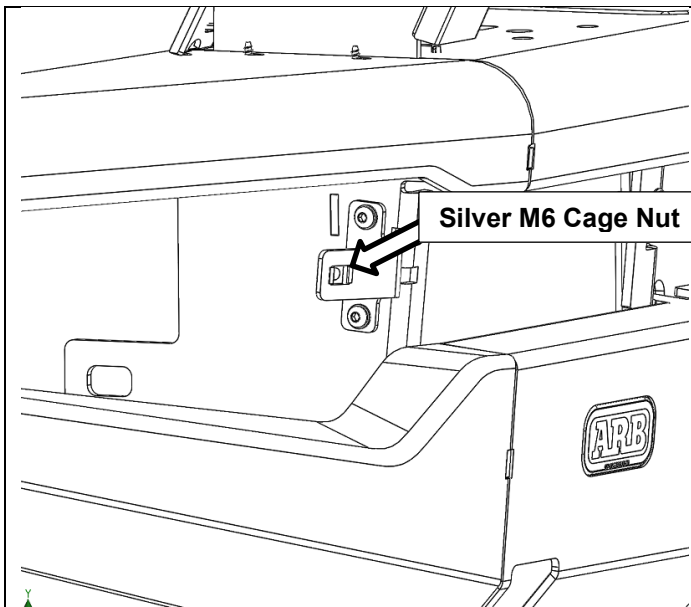

46. Assemble both fog cluster mounting brackets onto the outside of the uprights with M6 flange bolts and flange nuts. Torque to specification.
47. Assemble silver M6 cage nuts into both fog cluster mounting brackets.

 M6 - 9 Nm.

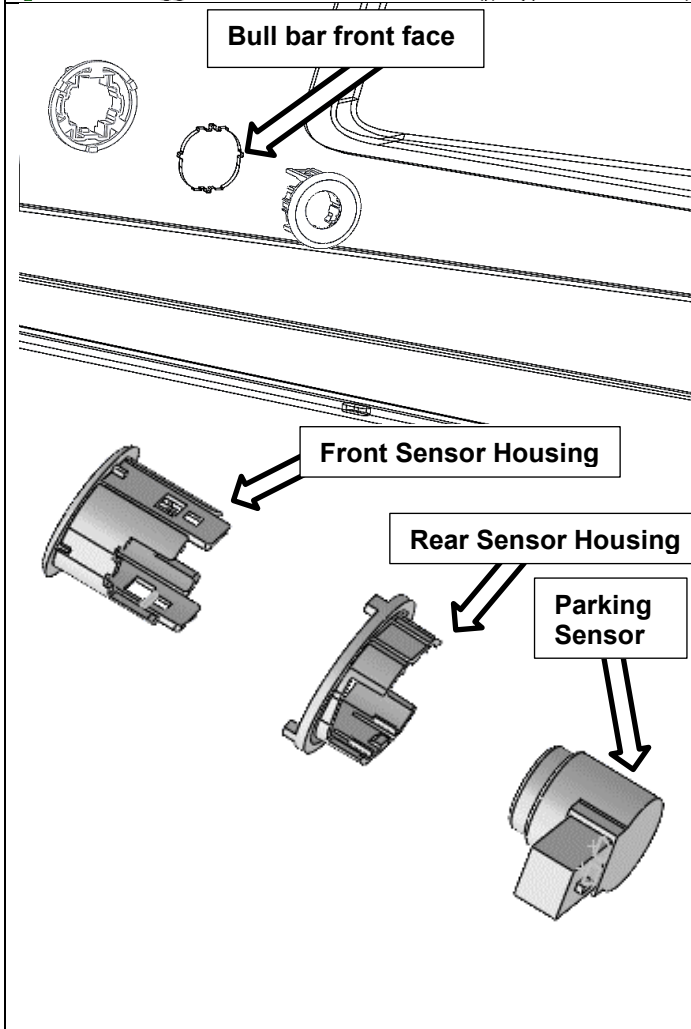

48. Fit the front sensor housing from the front of the bull bar into the designated aperture.
49. Fit the rear sensor housing to the rear side of the bull bar.

Note: Ensure the two pieces engage correctly and are secure.

50. Fit the parking sensor into the sensor housing. Ensure the tails of the sensors are in the same orientation as found in the bumper.
51. Fit wiring loom (removed from bumper) and connect to inner parking sensors. Secure with cable ties.



52. Identify harness extension 6821451



53. Connect harness extension to the two most outer parking sensor connectors on the OEM harness. on the vehicle and secure with cable ties.

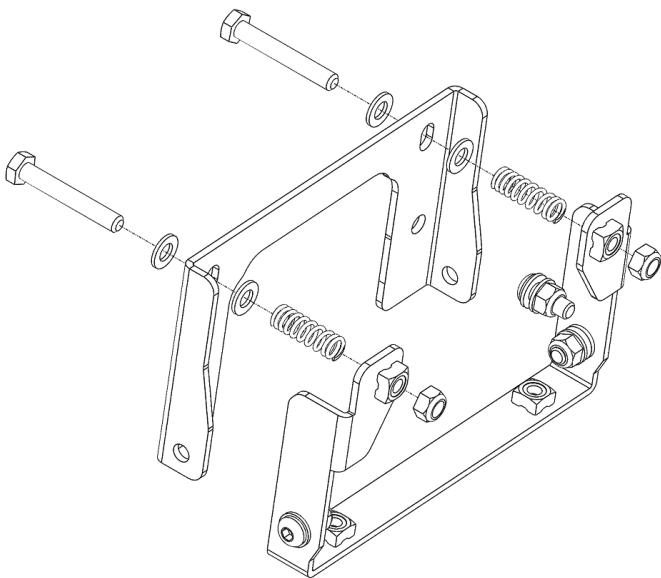

54. Install two M6x40mm hex head screws, four 12mm M6 washers, two M6 nyloc nuts and two springs into the slotted holes of radar bracket 37500120 as shown. Do not overtighten nuts, screws need to be free to spin.

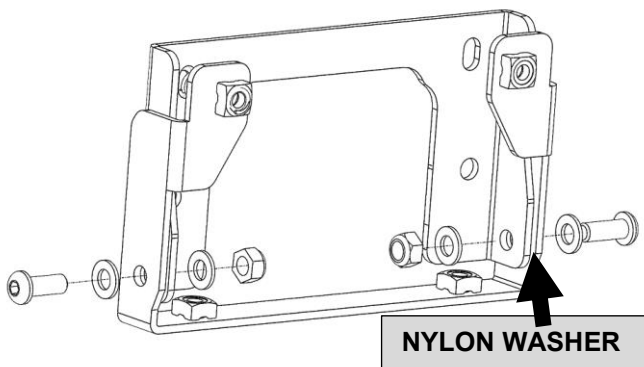

55. Attach the radar bracket to the mounting bracket using two M6x20mm button head screws, four 16mm M6 washers, two M6 nyloc nuts and two nylon spacers.

Ensure nylon spacer is placed between steel components

56. Thread screws installed in step **Error! Reference source not found.** into weld nuts. This will enable adjustment of radar bracket.

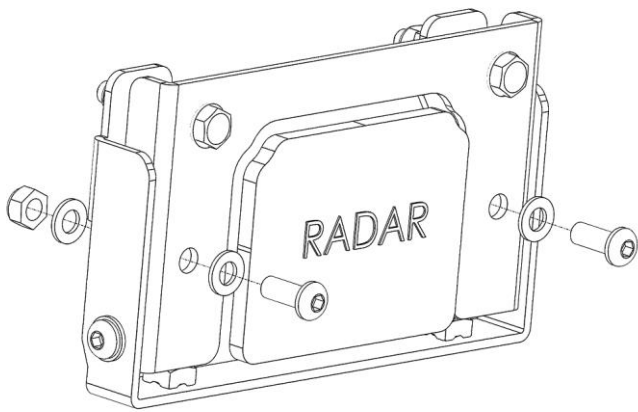

57. Install radar module removed in Step 22 into radar bracket assembly using two M6x16mm button head screws, four 16mm M6 washers and two M6 nyloc nuts.

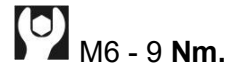

Warning: Care must be taken not to drop radar module.

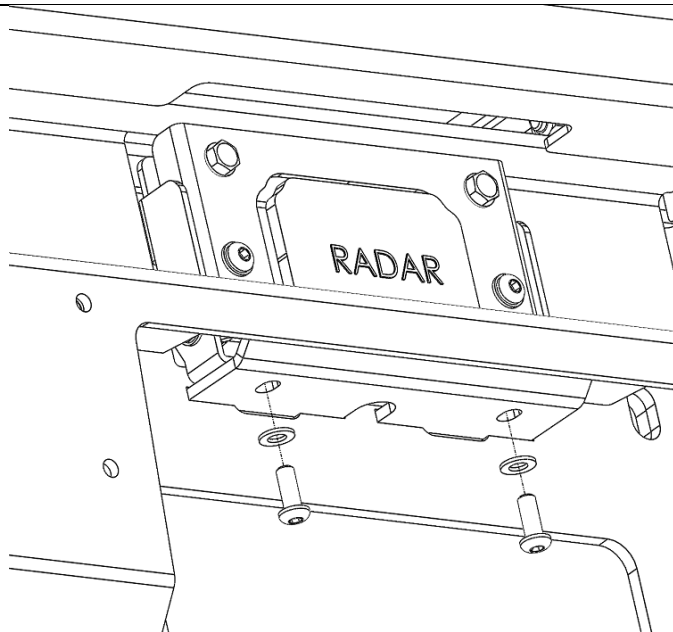

58. Insert radar bracket into the bull bar from the front and secure using two M6x16mm button head screws, two 16mm M6 washers. Torque to spec.

Note: Screws must be inserted from underneath.

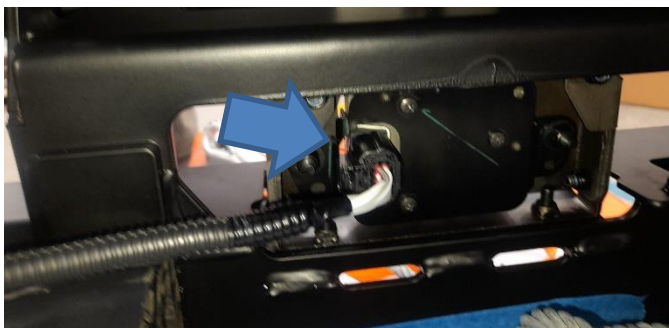
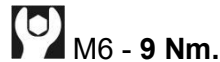

59. Connect radar extension loom to radar module. Use cable ties to secure to a suitable area.

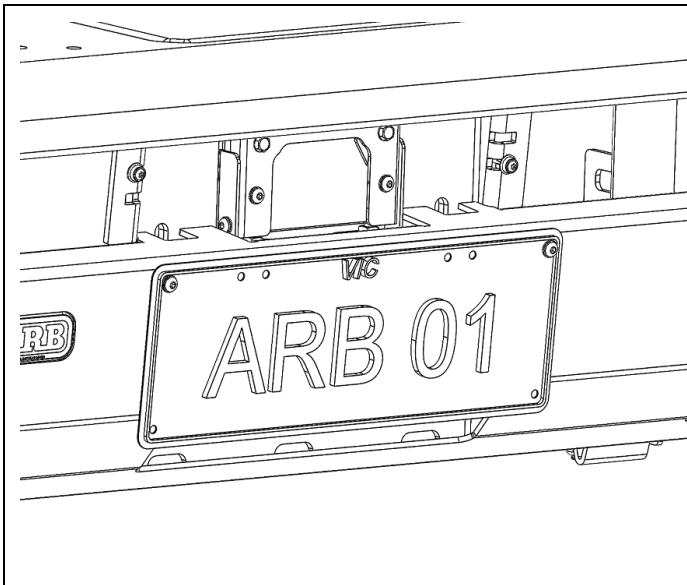

60. Fit number plate using two M6x16mm button head screws, two M6 nyloc nuts and four M6x12.2x1.2 flat washers.

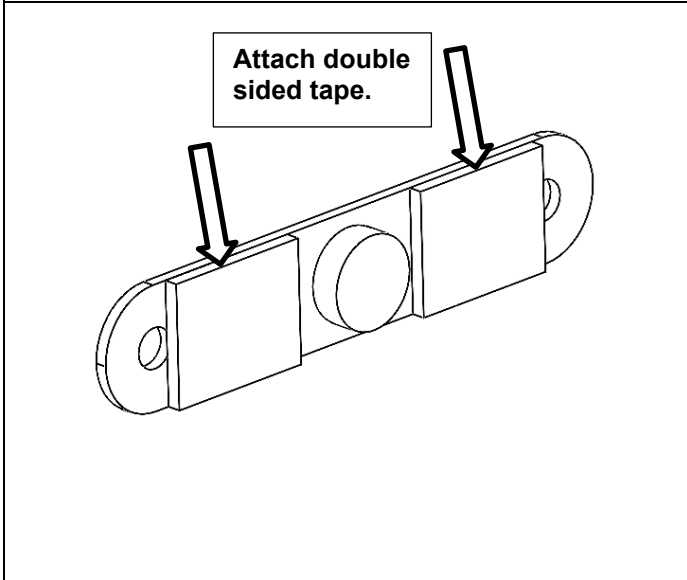
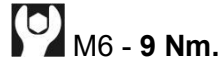

61. If vehicle does **not** have a front camera fitted, attach double sided tape to blanking bracket as shown. Attach the bracket behind the bulbar camera hole, to fill the opening.

If vehicle **does** have front camera, proceed to next step.

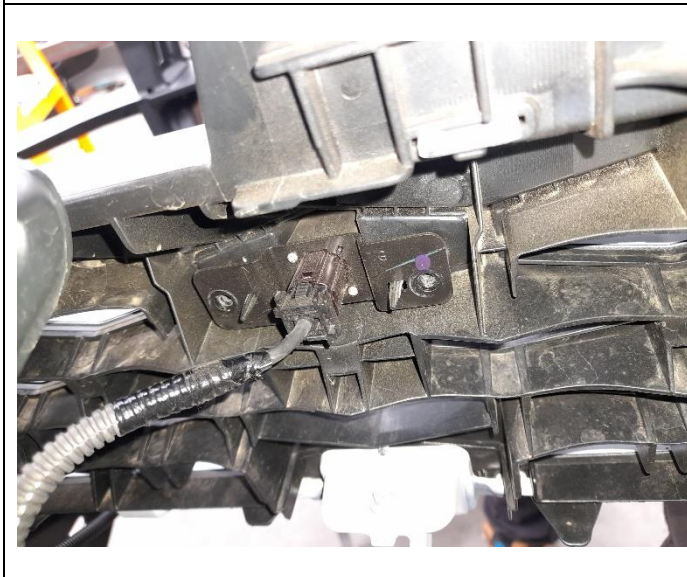

62. Remove 2 screws and remove camera from top of grille. Unplug connector.
63. Remove the two small screws fastening the camera to the factory camera bracket. Discard the factory camera bracket.

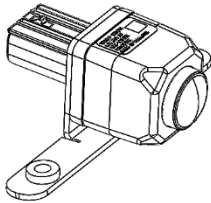

64. Fasten the camera to one of the two camera brackets supplied (whichever one fits the vehicle camera, depending on spec level.) using the OEM screws. Discard the unused camera bracket.

65. Attach camera bracket to bullbar using 2x M4 button head screws

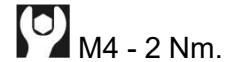
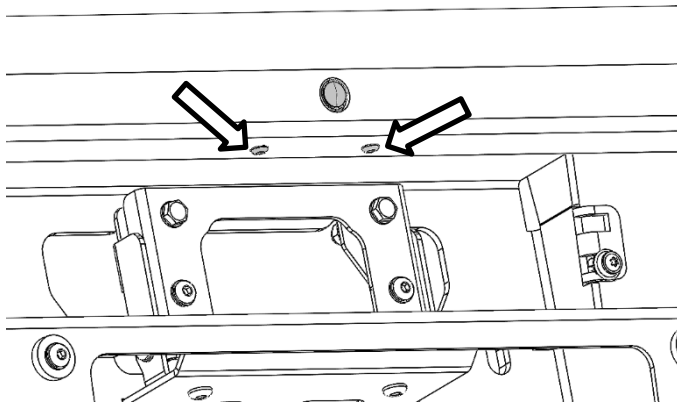

66. Remove camera cable/horn cable clip from vehicle body using a flat blade screwdriver or similar. Remove black tape from cables to allow full lengths.
67. Remove bolt securing passenger side horn. Discard bolt.





68. Relocate passenger side horn as shown. Secure with an M6x20mm button head bolt (supplied). This will allow full extension of the camera cable.

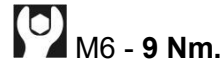

Installation of wiring harness

69. Refer to 37800275 for CAN harness installation instructions – provided in kit.
70. Refer to 37800543 for 26+ Hilux specific CAN bus installation instructions – provided in kit.
71. Refer to ARB CAN Connect user guide provided with ARB CAN module for configuring module to vehicle.



72. Route cables through grommet as shown.

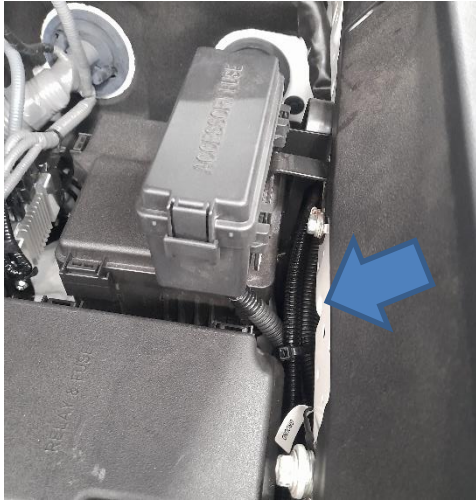

73. Route wiring along passenger side guard, and beside fuse box. Use cable ties to secure.



74. Move bar close to the front of the vehicle and connect camera cable to camera.



Fitment of bull bar to vehicle

75. With the assistance of another person, place the bar on the vehicle mount brackets.

WARNING: Due to the weight of the bar and winch if fitted, it is advised that you use some form of mechanical assistance when lifting the bar onto the vehicle such as an elevating trolley.

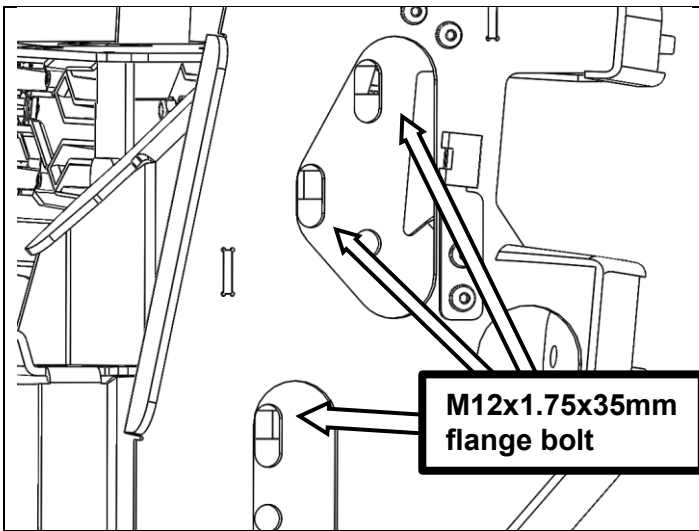

76. With the bull bar sitting in place, fit three black M12x1.75x35 flange head bolts and M12 flange nuts per side. Leave finger tight for now.



77. Check the clearance of the bar to the vehicle, and adjust position of bar left/right until it's sitting central to body, then tighten all fasteners joining mount assembly to chassis brackets (six M10 ARB and two M10 OEM bolts each side).

 M10 – 44Nm

78. Tighten all inner and outer M12 chassis support bracket fasteners.

 M12 – 77Nm

79. Once bull bar has been positioned central to the body, adjust bull bar on mounting slots to achieve a parallel 20mm gap between wings and bumper cut profile.

Wing return should align to wheel arch tangent.

Torque M12 mounting bolts to specification.

 M12 - 77 Nm.

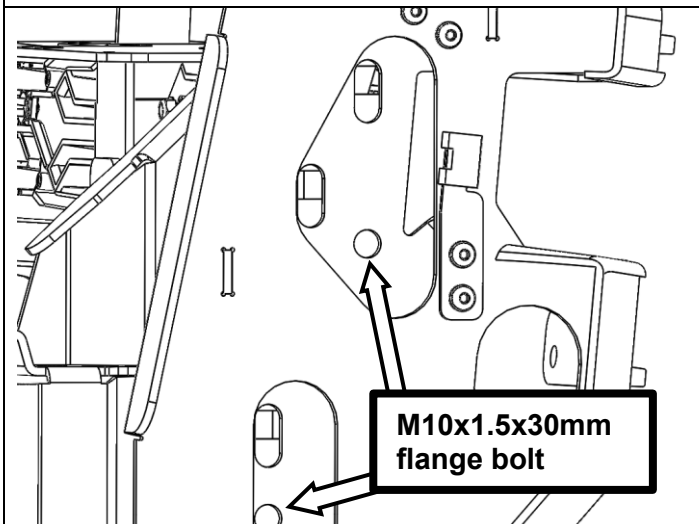

80. Drill four Ø10mm holes (2 per side) through mount assembly using existing holes in bull bar as guide. This may require a right-angled drill.



81. Add anti-corrosion touch up paint to areas drilled, then assemble and tension four M10x30 flange bolts and flange nuts to specification.

 M10 - 44 Nm.

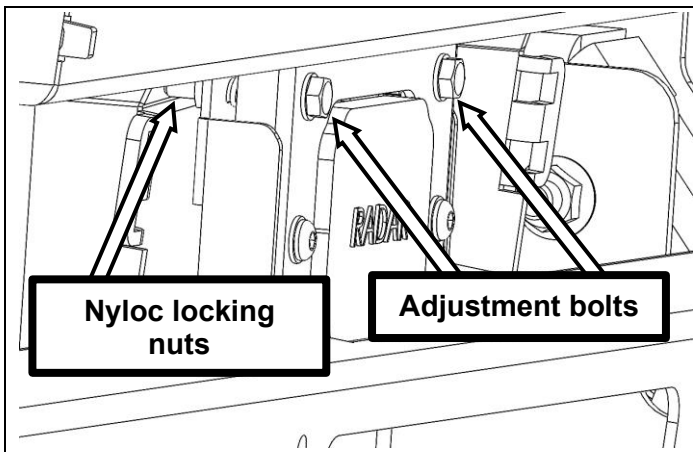

82. Place a digital level on the front face of the radar. The front face should be 90 degrees to level ground with a tolerance of ± 1 degree. Turn the two adjustment bolts evenly to alter the angle of the radar module to fall within this tolerance.
83. With radar positioned correctly, install two M6 nyloc nuts against the captive nuts (rear), to lock rotation of adjustment bolts. Ensure that the adjustment bolts do not rotate as the nyloc nuts are torqued to specification.

 M6 - 9 Nm.

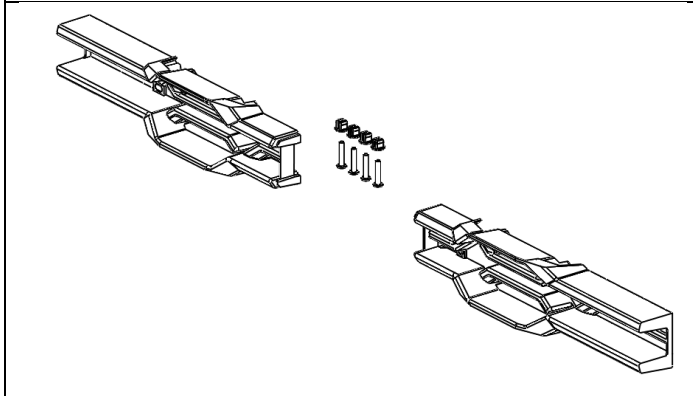

84. Identify the outer grille section kit, 3163295.

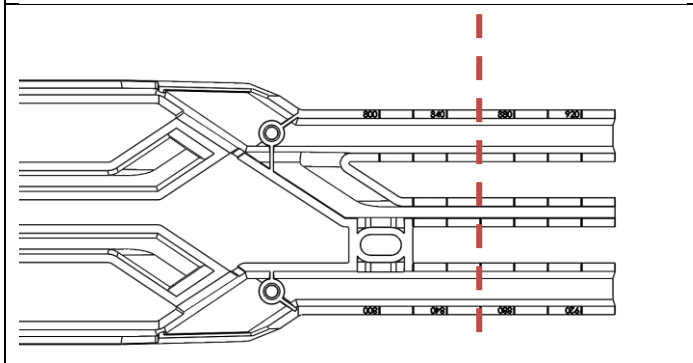

85. Mark both grille panels to be cut at the 920mm markings on the back face.

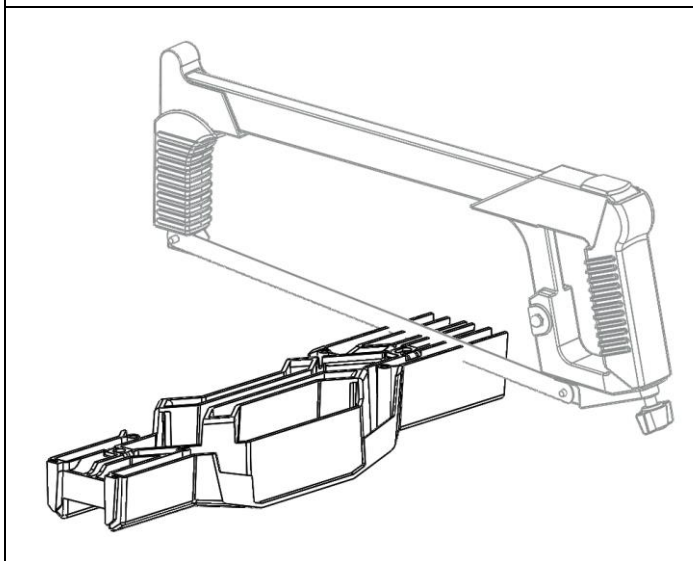

86. Use a hacksaw or similar cutting tool to carefully cut the grille panel at the positions marked in the step above.

Discard the off cuts and clean up the cut edges using a file or sandpaper.

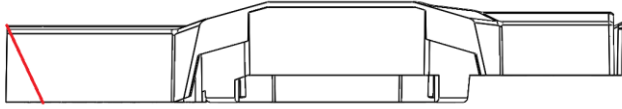

87. Mark cut grille section at the 840 mm markings, before cutting diagonally, connecting to initial cut.

BEFORE

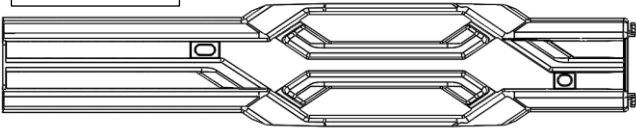

AFTER

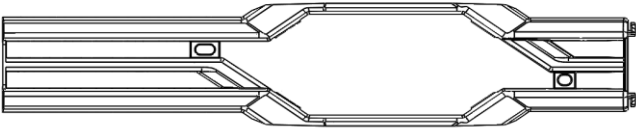

88. If fitting a winch, remove grille sections shown for access to clutch lever.

Cut from rear with an oscillating multi-tool.

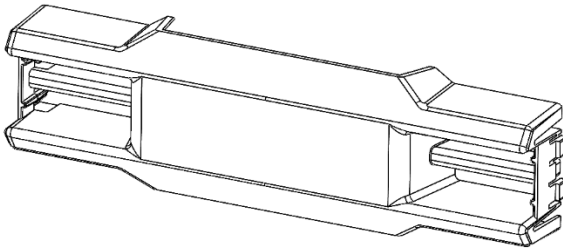

89. Identify the radar cover section kit, 3163290.

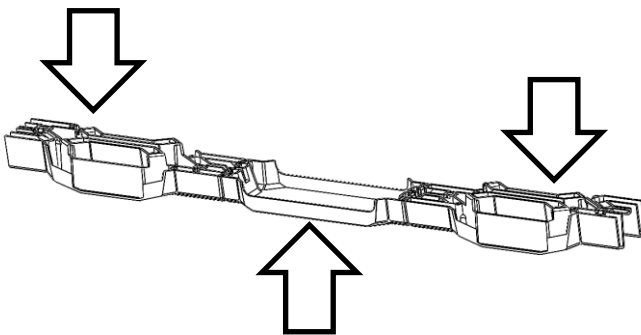

90. Assemble centre section with both outer sections included in kit 3163295. Make sure clips are fully engaged.

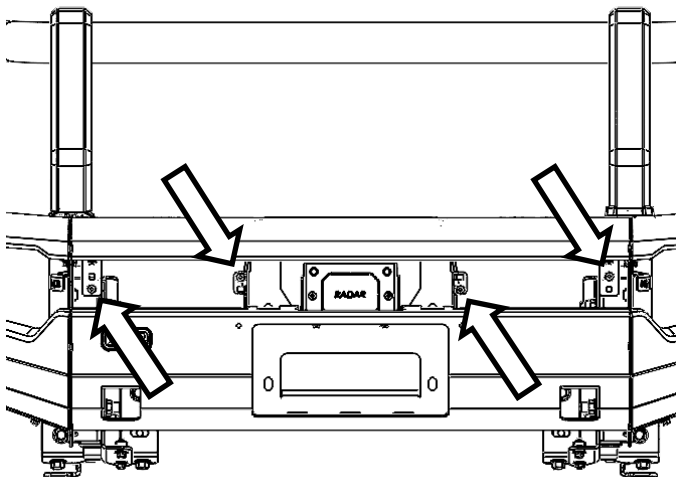

91. Press four round plastic grommets from grille kit into the square cut-outs seen from the front of the bull bar.

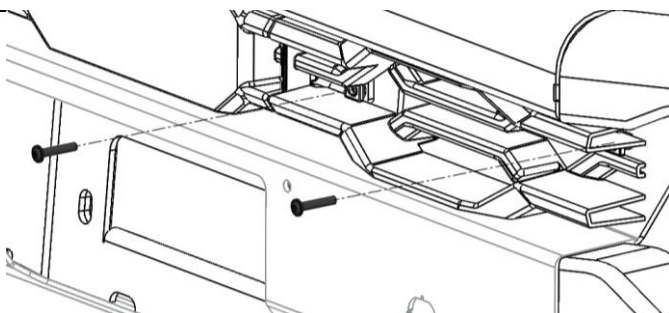
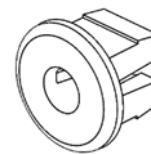

92. Attach grille assembly to bull bar using four torx head screws supplied in grille kit.

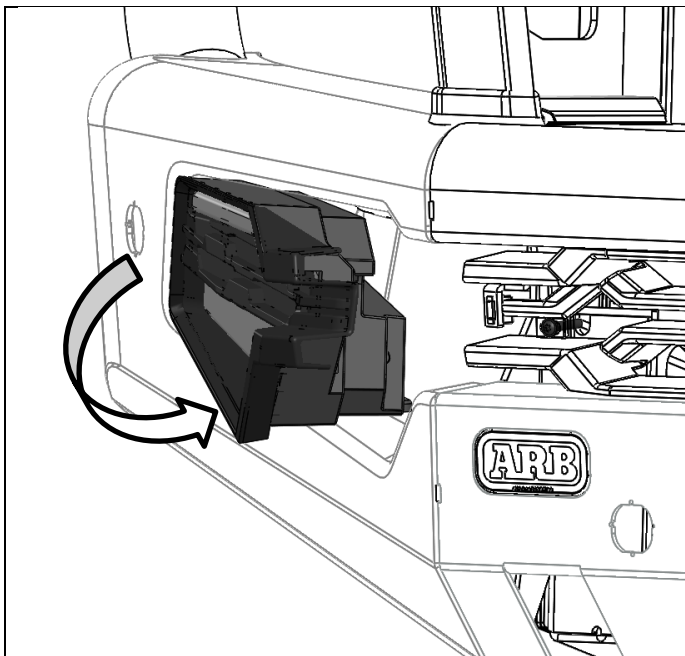

93. Index the outside groove of the lamp cluster over the edge of the aperture in the bull bar wing. Then rotate the lamp cluster into place.

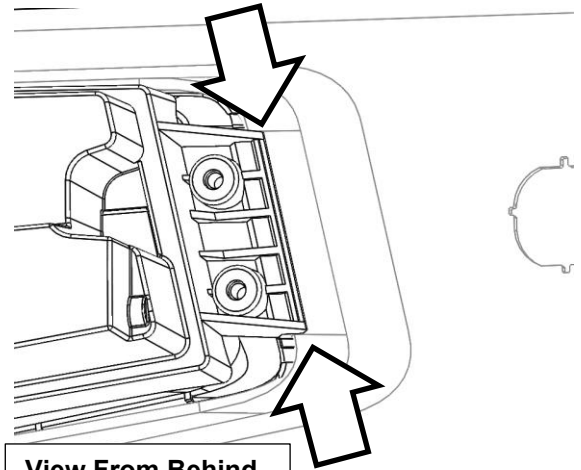

View From Behind

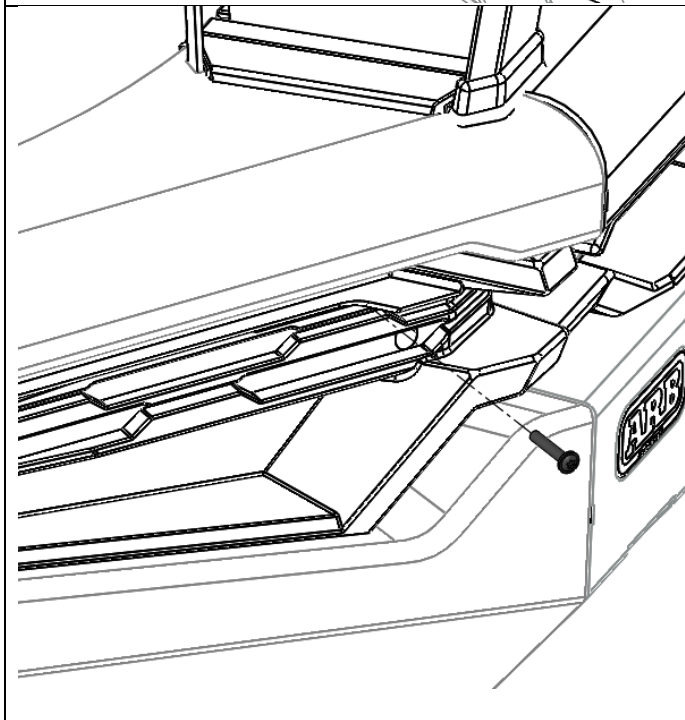

94. Secure lamp cluster with an M6 torx head screw.

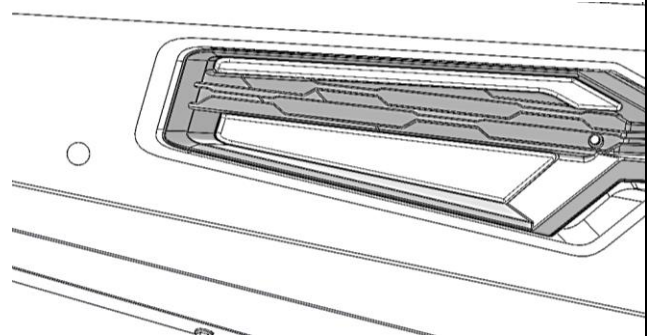

 M6 - 9 Nm.

Note: push lamp cluster hard against the aperture in the bull bar wing when fastening.

Connect lighting harness into the back of each fog cluster.

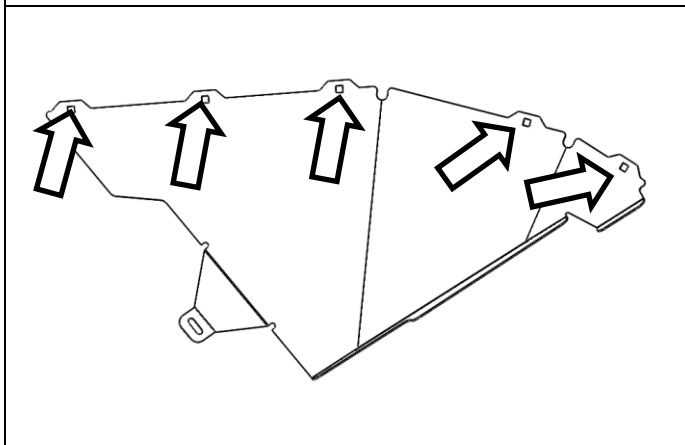

95. Fit five M6 cage nuts to each wing under panel.

Note: Cage nut heads to be located on top side.



96. Temporarily place the wing under panel in position, and mark lines onto the OEM inner guards (LH & RH) using lower edge of wing under panels as guide ensuring enough guard remains so that it may be neatly tucked/secured behind wing under panel lip.

Caution: Use care not to damage the windscreen washer bottle or hoses when trimming LH inner guard.

97. Carefully cut along marked lines using jig-saw or shears.



Warning: Drilling operations can result in flying metal debris, safety glasses should be worn.

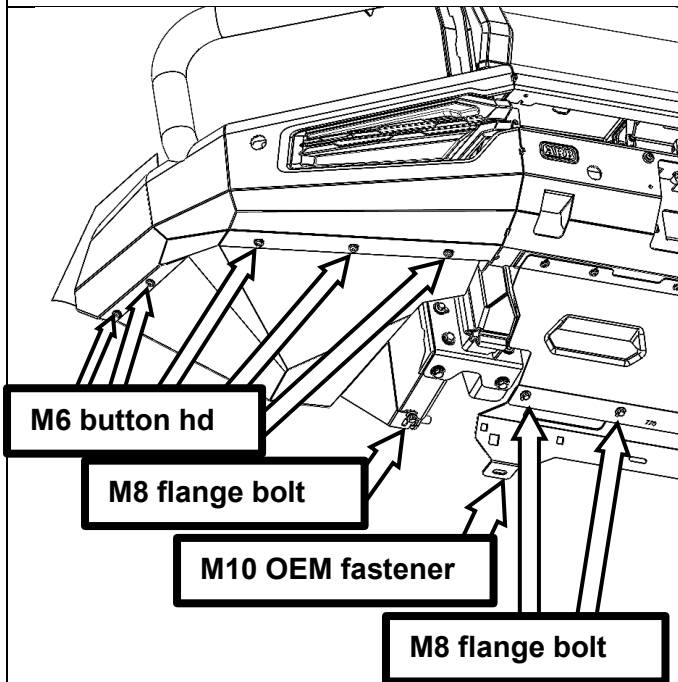

98. Remove factory bash plate and install rear underpanel using the 2x OEM M10 bolts. Re-install factory bash plate.

99. Fasten centre panel to rear panel using four M8 flange bolts and fasten to bar using 6x M6 button head screws

Fasten wing under panels to bull bar using ten M6 button head bolts.

Fasten lower corner of wing under panel using two M8x1.25x20mm flange bolts and M8 flange nuts



M6 – 9Nm



M8 – 22Nm



M10 – 44Nm



100. e-install upper radiator cover panel and fasten using eight OEM scrivenets.

FITTED PRODUCT – TOYOTA HILUX SUMMIT MKII

NOTICE: ONCE SUMMIT BAR IS FITTED:

- ◆ Ensure all bolts are tensioned correctly.
- ◆ All wiring is clear of sharp edges or moving surfaces and secured properly.
- ◆ Piping is secured well away from sharp or moving components.
- ◆ Check operation of winch, if fitted.
- ◆ Check all wiring and connections to turn signal lamps and clearance lights and that they are functioning correctly.

