



# FITTING INSTRUCTIONS

Part Number: **5414210**

Product Description: UVP FRONT KIT

Suited to vehicle/s: SUIT HILUX MY25 0N

**Please place these instructions in vehicle glovebox when complete.**

## **WARNING**

### **REGARDING VEHICLES EQUIPPED WITH SRS AIRBAG:**

When installed in accordance with these instructions, the vehicle protection panels do not affect operation of the SRS airbag.

### **ALSO, NOTE THE FOLLOWING:**

- ◆ This product must be installed exactly as per these instructions using only the hardware supplied.
- ◆ Do not use this product for any vehicle make or model, other than those specified by ARB.
- ◆ Do not remove labels (if any) from this product.
- ◆ This product or its fixing must not be modified in any way.
- ◆ The installation of this product may require the use of specialized tools and/or techniques.
- ◆ These instructions are correct as at the publication date. ARB Corporation Ltd. cannot be held responsible for the impact of any changes subsequently made by the vehicle manufacturer.
- ◆ During installation, it is the duty of the installer to check correct operation/clearances of all components.
- ◆ Work safely at all times.
- ◆ Unless otherwise instructed, tighten fasteners to specified torque.

## **ARB 4x4 ACCESSORIES**

Corporate Head Office

42-44 Garden St  
Kilsyth, Victoria  
AUSTRALIA 3137

Tel: +61 (3) 9761 6622  
Fax: +61 (3) 9761 6807

Australian enquiries  
North & South American enquiries  
Other international enquiries

sales@arb.com.au  
sales@arbusa.com  
exports@arb.com.au

[www.arb.com.au](http://www.arb.com.au)

# IMPORTANT INFORMATION. GENERAL CARE AND MAINTENANCE

By choosing ARB vehicle protection, you have bought a product that is one of the most sought after 4WD products in the world. Your under vehicle protection panels are a properly engineered, reliable, quality accessory that represents excellent value.



- While these panels have been engineered for strength and functionality, care and good judgment should be taken when traversing difficult off-road conditions to minimise damage to panels and vehicle.
- During servicing when panels are removed, ensure fasteners are re-fitted to the correct torque values.
- Inspect panels visually on a regular basis. Dirt and foreign matter should be washed out to minimise build-up around hot components. **BE VERY CAREFUL** when removing foreign matter with hands while vehicle is hot or running. Replace any components as necessary. This service can be performed by your local authorized ARB Stockist.

## FITTING REQUIREMENTS

### REQUIRED TOOLS FOR FITMENT OF PRODUCT:

BASIC TOOL KIT	TORQUE WRENCH
----------------	---------------

### HAVE AVAILABLE THESE SAFETY ITEMS WHEN FITTING PRODUCT:



Protective eyewear	
Hearing protection	

**NOTE: 'WARNING' notes in the fitting procedure relate to OHS situations, where to avoid a potentially hazardous situation it is suggested that protective safety gear be worn or a safe work procedure be employed. If these notes and warnings are not heeded, injury may result.**

### FASTENER TORQUE SETTINGS (unless otherwise specified):

SIZE	Torque Nm	Torque lbft
M8	22	16

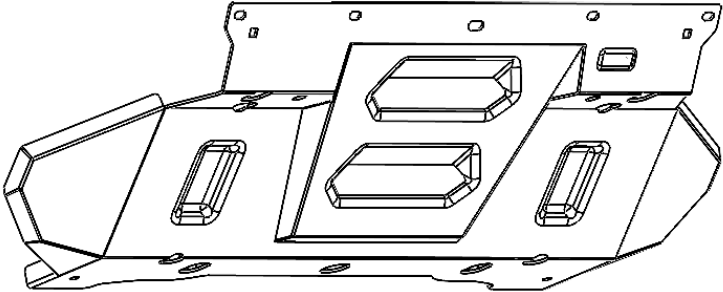
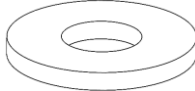
## PARTS LISTING

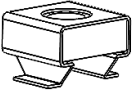
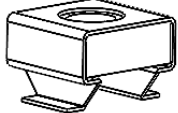
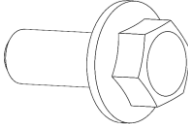
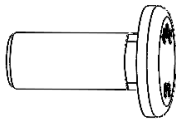
PART NUMBER	DESCRIPTION.	QTY.	DIAGRAM.
6523816	UVP FRONT WELDMENT	1	
4581307	WASHER FLAT M8x20x2	2	
6151212	NUT HEX NYLOC M8x1.25	2	
6151300	NUT CAGED M6 2.6-3.5   956-C	2	
6151301	NUT CAGED M8 3.3-4.7   1238-C	4	
6151730	BOLT HXHD FL M8x1.25x20	8	
6151921	BOLT COHD M8x20   ZNB480 LWHD	2	

## FITTING PROCEDURE

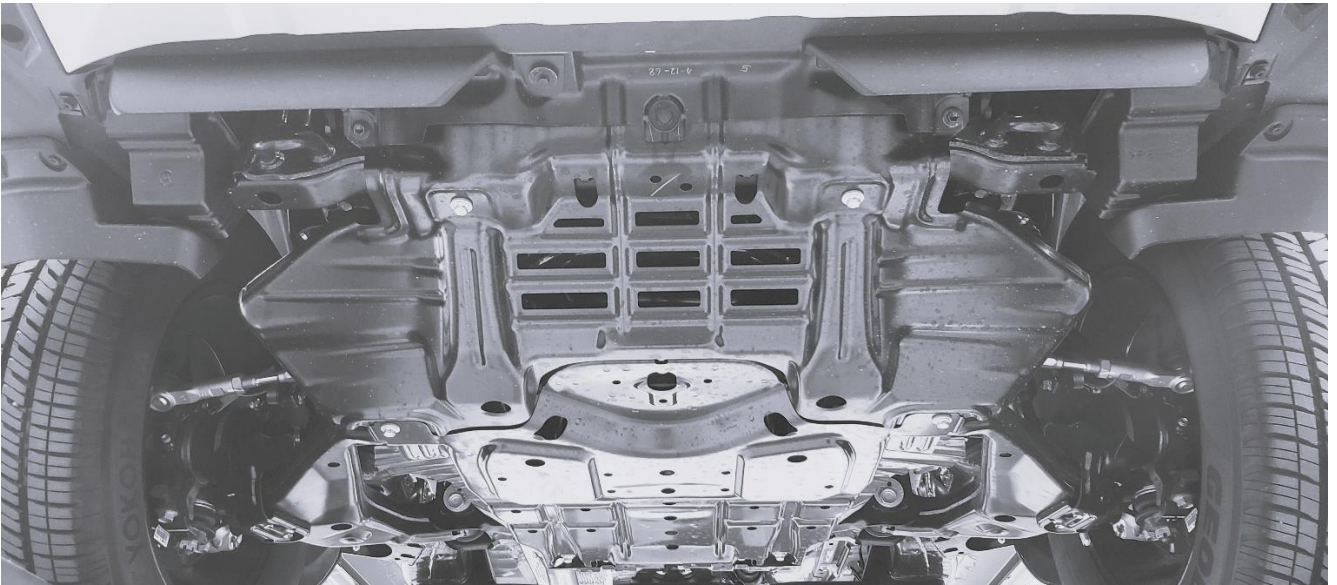

1. Lift the vehicle to a safe working height.

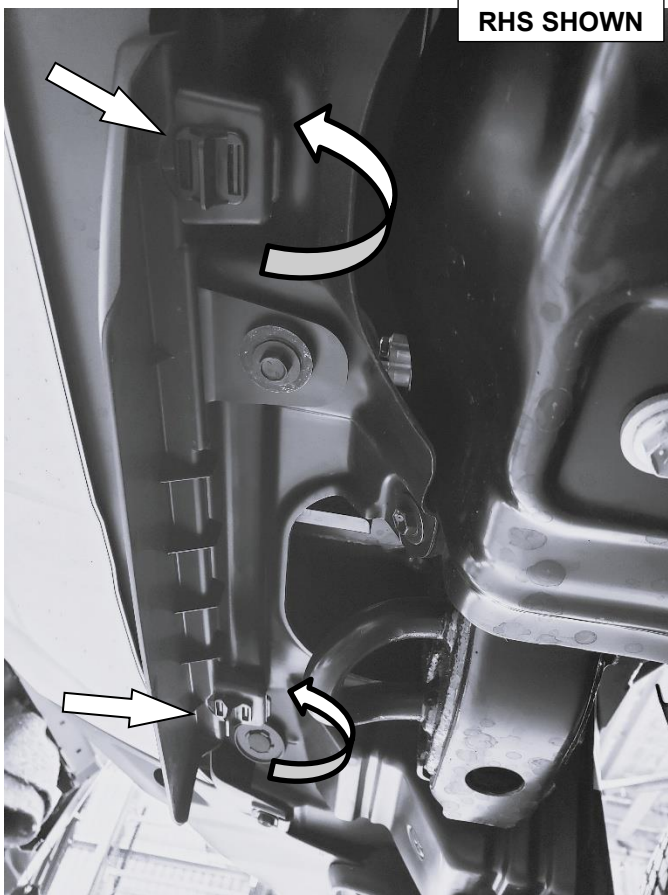

2. Remove the inner air dams by twisting the clips 90° and pull down.
3. Slide the air dam reward off the bumper.

Place aside for refitment.  
Repeat on the LHS.

RHS SHOWN

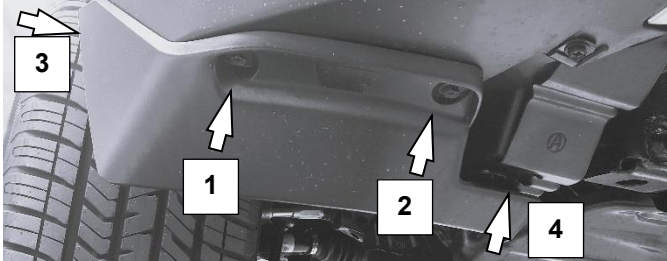

4. Remove the outer air dam fasteners in the order shown.

Place aside for refitment.  
Repeat on the LHS.

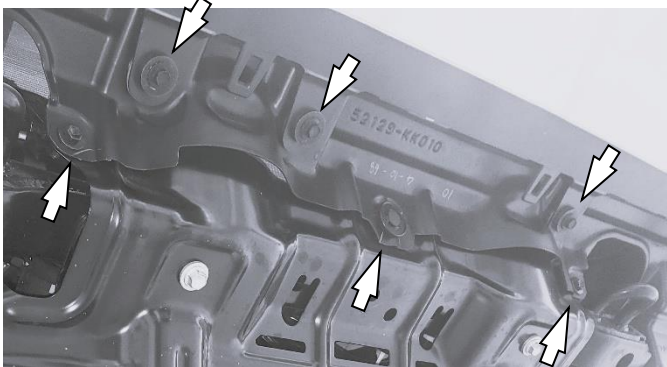

5. Remove the three fasteners retaining the lower bumper.
6. Remove the two outer Bolts and one centre Scrivet.

Place aside for refitment.

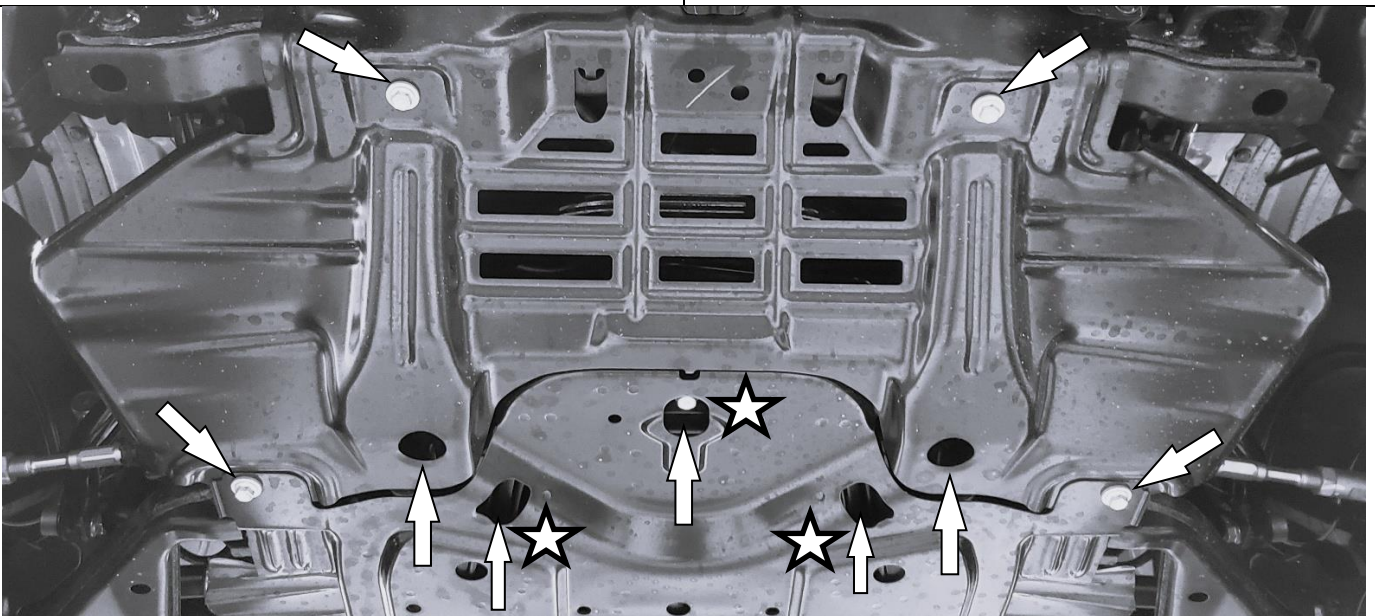

7. Remove the rear most seven fasteners, the centre three (noted with a star) will be reinstalled.

8. Remove the forward two fasteners.

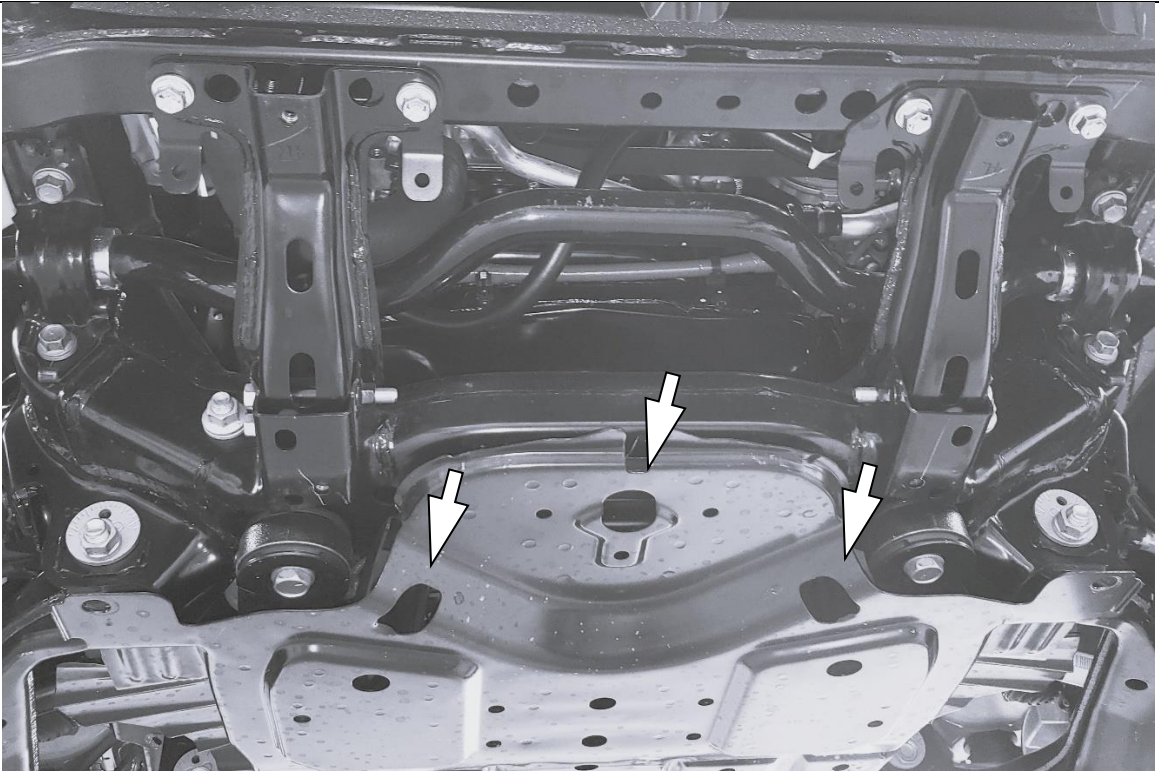

9. Gently pull down the second factory panel and remove the front panel.
10. Refit the three fasteners noted in Step 7. And Torque to specification.

 M8 - 22 Nm.

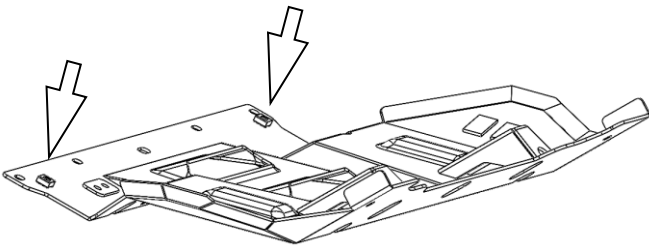

11. Place the UVP panel on a soft flat surface to prepare for fitment.
12. If fitting to the factory bumper, insert two M6 cage nuts as shown.

**NOTE:**  
If fitting with an ARB bull bar, refer to the relevant instructions for the rear stone tray fitment.



13. To fit the UVP front panel, gently pull the lower plastic bumper forward and lift the UVP panel up and into the space.
14. Lift the rear of the UVP panel and then backwards to sit on top of the second factory under panel.
15. Loosely fit two M8 FL x 20 bolts at the front to hold the UVP panel on the vehicle.

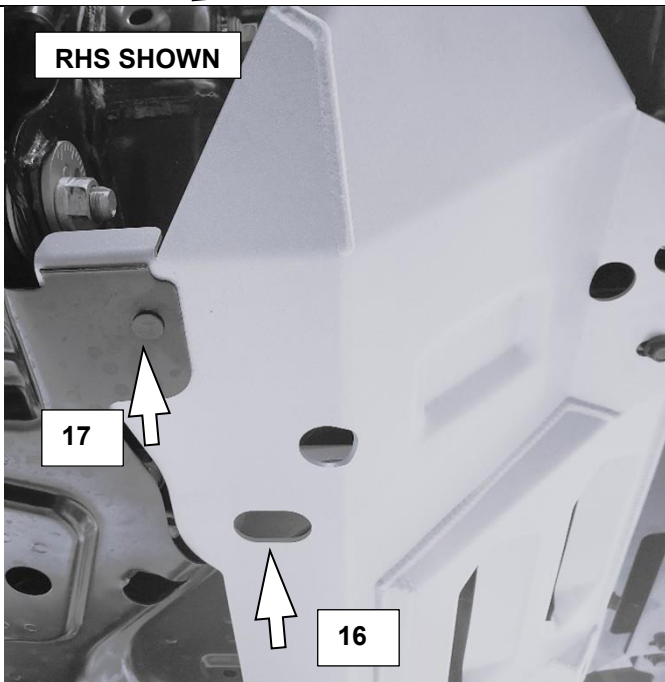
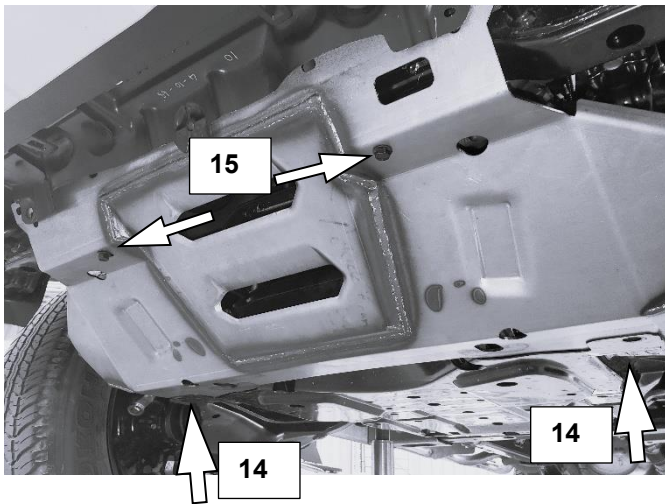

16. Loosely fit two M8 FL x 20 bolts at the rear through the slots.
17. Per side, attach the factory panel to the UVP panel using one M8 coach bolt with one washer and one M8 Nyloc nut on the inside.

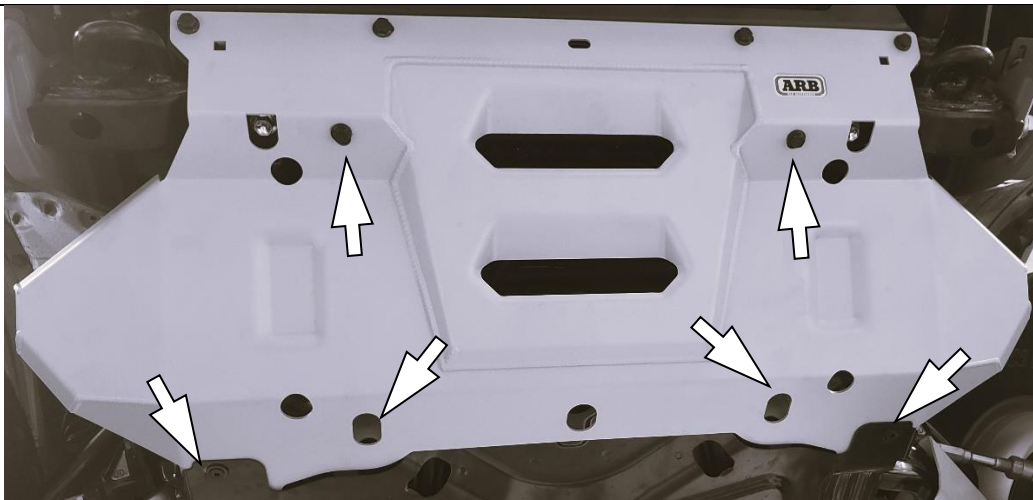

18. Torque the six M8 fasteners to specification.

 M8 - 22 Nm.

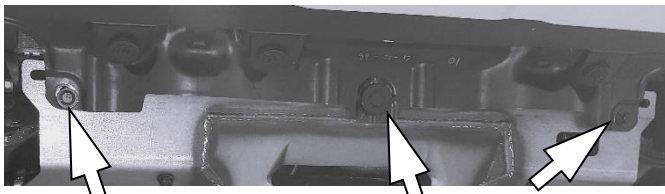

19. Refit fasteners and components removed in Step 2 to 6 in the reverse order.  
20. Two M6 bolts and the centre Scrivet not fit to the UVP panel.



### FITTED UVP

