



# FITTING INSTRUCTIONS

PART NUMBER: **3414780**

PRODUCT DESCRIPTION: **COMMERCIAL BAR**

SUITED TO VEHICLE/S: **TOYOTA HILUX 2026ON  
WORKMATE, SR AND SR5 MODELS**

OPTIONAL FITTING KITS: **3540050 WINCH INSTALL KIT  
3500605 – HAWSE SPACER KIT NARROW**

## WARNING

### REGARDING VEHICLES EQUIPPED WITH SRS AIRBAG:

When installed in accordance with these instructions, the front protection bar does not affect operation of the SRS airbag.

### ALSO, NOTE THE FOLLOWING:

- ◆ This product must be installed exactly as per these instructions using only the hardware supplied.
- ◆ In the event of damage to any bull bar component, contact your nearest authorised ARB stockist. Repairs or modifications to the impact absorption system must not be attempted.
- ◆ Do not use this product for any vehicle make or model, other than those specified by ARB.
- ◆ Do not remove labels from this bull bar.
- ◆ This product or its fixing must not be modified in any way.
- ◆ The installation of this product may require the use of specialized tools and/or techniques.
- ◆ It is recommended that this product is only installed by trained personnel.
- ◆ These instructions are correct as at the publication date. ARB Corporation Ltd. cannot be held responsible for the impact of any changes subsequently made by the vehicle manufacturer.
- ◆ During installation, it is the duty of the installer to check correct operation/clearances of all components.
- ◆ Work safely at all times.
- ◆ Unless otherwise instructed, tighten fasteners to specified torque.

## ARB 4x4 ACCESSORIES

### Corporate Head Office

42-44 Garden St  
Kilsyth, Victoria  
AUSTRALIA 3137

Tel: +61 (3) 9761 6622  
Fax: +61 (3) 9761 6807

Australian enquiries  
North & South American enquiries  
Other international enquiries

sales@arb.com.au  
sales@arbusa.com  
exports@arb.com.au

[www.arb.com.au](http://www.arb.com.au)

## GENERAL CARE AND MAINTENANCE

By choosing an ARB Bar, you have bought a product that is one of the most sought after 4WD products in the world. Your bar is a properly engineered, reliable, quality accessory that represents excellent value. To keep your bar in original condition it is important to care and maintain it following these recommendations:



- Prior to exposure to the weather your bar should be treated to a Carnauba based polish on all exposed surfaces. It is recommended that this is performed on a six-monthly basis or following exposure to salt, mud, sand or other contaminants.
- As part of any Pre-Trip Preparation, or on an annual basis, it is recommended that a thorough visual inspection of the bar is carried out, making sure that all bolts and other components are torqued to the correct specification. Also check that all wiring sheaths, connectors, and fittings are free of damage. Replace any components as necessary. This service can be performed by your local authorized ARB Stockist.

## FITTING REQUIREMENTS

### REQUIRED TOOLS FOR FITMENT OF PRODUCT:

BASIC TOOL KIT	ELECTRIC DRILL WITH METRIC Ø10 DRILL BIT
JIG SAW OR OSCILLATING MULTITOOL WITH BLADE SUITABLE FOR PLASTIC	LOW TACK MASKING TAPE
FILE	UTILITY KNIFE
TAPE MEASURE	WHITE FELT MARKER
STEEL RULE	TORQUE WRENCH
TOUCH UP PAINT ANTI CORROSION	RIGHT ANGLE ELECTRIC DRILL
BLACK SPRAY PAINT OR BLACK SELF-ADHESIVE VINYL	

### HAVE AVAILABLE THESE SAFETY ITEMS WHEN FITTING PRODUCT:

<b>Protective eyewear</b>		<b>Hearing protection</b>	
---------------------------	---	---------------------------	---

**NOTE: 'WARNING' notes in the fitting procedure relate to OHS situations, where to avoid a potentially hazardous situation it is suggested that protective safety gear be worn or a safe work procedure be employed. If these notes and warnings are not heeded, injury may result.**

### FASTENER TORQUE SETTINGS:

SIZE	Torque Nm	Torque lbft
M6	9Nm	7lbft
M8	22Nm	16lbft
M10 PC8.8	44Nm	32lbft
M12 PC8.8	77Nm	57lbft

## PARTS LISTING

APPLICATION	PART NO.	QTY	DESCRIPTION
MOUNTS TO VEHICLE	4655863R	1	CHASSIS MOUNT RHS HILUX 26 ON
	4655863L	1	CHASSIS MOUNT LHS HILUX 26 ON
	37501190R	1	CHASSIS BRKT OUTER RHS HILUX
	37501190L	1	CHASSIS BRKT OUTER LHS HILUX
	3759666R	1	BRKT CHASSIS IN HILUX 15ON RHS
	3759666L	1	BRKT CHASSIS IN HILUX 15ON LHS
	4722161	2	CRUSH TUBE M12 29.5 OD
	4722162	2	CRUSH TUBE M12 20 OD
	6151689	4	BOLT HXHD M12x1.25x90   PC10.9 ZP
	4584363	8	WASHER FLAT M12x26x4   HV300 TZP480
	6151835	4	NUT HEX NYLOC M12x1.25   PC10.9
	4584410	2/8	WASHER FLAT M12x31.75x2.5
	6151545	2/8	BOLT HXHD FL M12x1.25x35   PC8.8 BTZP480
	6151321	12/16	NUT FLANGE M10x1.5   PC8.8 TZP480 SERRATED
	4584399	20/24	WASHER FLAT M10x25x3   ZNB480
	6151965	12/16	BOLT HXHD FL M10x1.5x30   PC8.8 ZNB480
6151698	4	BOLT HXHD FL M10x1.25x40   PC8.8 BTZP480	

APPLICATION	PART NO.	QTY	DESCRIPTION
CAMERA, RADAR AND PARKING SENSORS	37501308	1	BRKT CAMERA MY26 HILUX COM
	37501334	1	BRKT CAMERA LS MY26 HILUX
	4656065	1	BRKT CAM BLNK MY26 HILUX
	6781438	1	TAPE 3M4991 - 2.3MM VHB 20X25 2PCS
	37501310	1	BRKT RADAR OUT MY26 HILUX COM
	37500327	1	RADAR BRKT UPPER SUIT J250
	6821189	4	GROMMET RND FC 1500 080 090
	6151384	4	SCREW ST PHD 5.2x16   PH PC8.8 BTZP480
	6151729	6/22	BOLT HXHD FL M6x1.0x20   PC8.8 ZNB480
	4584327	6/8	WASHER FLAT M6x16x1.2   BTZP480
	6151223	6/8	NUT HEX NYLOC M6x1.0   ZNB480
	6151584	2	BOLT HXHD M6x1.0x40   PC8.8 BTZP
	5670069	2	SPRING COMP STAINLESS 25X6.0ID
	4584421	2	WASHER FLAT M6X18X1.6 NYLON
	6821451	2	HARNESS EXTENSION SUITS TOYOTA
	3525010	1	SENSOR SURROUND KIT (4)
	3163222	2	PLUG SNSR BLANKING PAIR
	3163339	1	RADAR COVER

APPLICATION	PART NO.	QTY	DESCRIPTION
WIRING, LIGHTS AND PLASTICS	3163015	1	OS LIGHT INDICATOR SURROUND KIT (PAIR)
	6821515	1	LAMP KIT LED REDUCED   INDICATOR CLEARANCE (PAIR)
	CANDEC	1	CAN BUS DECODER MODULE
	3514190	1	HARNESS CANBUS ADAPTOR HILUX26
	3501260	1	HARNESS CAN MODULE COMM BAR

APPLICATION	PART NO.	QTY	DESCRIPTION
BAR TO MOUNTS	4656031	1	WELDMENT COMBAR MY26 HILUX
	6151545	6/8	BOLT HXHD FL M12x1.25x35   PC8.8 BTZP480
	4584410	6/8	WASHER FLAT M12x31.75x2.5
	6151480	6	NUT FLANGE M12x1.25   PC8.8 TZP480 SERRATED
	6151965	4/16	BOLT HXHD FL M10x1.5x30   PC8.8 ZNB480
	4584399	4/24	WASHER FLAT M10x25x3   ZNB480
	6151321	4/16	NUT FLANGE M10x1.5   PC8.8 TZP480 SERRATED

APPLICATION	PART NO.	QTY	DESCRIPTION
NUMBER PLATE	6151443	2	SCREW BHD M6x20   BZP
	4584295	2	WASHER FLAT M6x12   BZP
	5848302	2	PACKER RB NYLON
	4584327	2/8	WASHER FLAT M6x16x1.2   BTZP480
	6151223	2/8	NUT HEX NYLOC M6x1.0   ZNB480

APPLICATION	PART NO.	QTY	DESCRIPTION
UNDER PANELS AND STONE PANEL	6523778	1	CENTRE PANEL HILUX
	6523845	1	REAR UNDERPANEL
	6523777R	1	UNDER WING PANEL RHS HILUX
	6523777L	1	UNDER WING PANEL LHS HILUX
	6151729	16/22	BOLT HXHD FL M6x1.0x20   PC8.8 ZNB480
	6151526	16	NUT CAGED M6 1.8-2.7   BZP480
	6151730	6	BOLT HXHD FL M8x1.25x20   FT PC8.8 BZP480 ENS14-001
	6151655	2	NUT FLANGE M8x1.25   PC8 TZP480 ENS 14/002

APPLICATION	PART NO.	QTY	DESCRIPTION
MISC	6191030	2	PINCH WELD 520mm
	180302	8	CABLE TIE 4.8 X 180 MM BLACK
	37800583	1	CUTTING TEMPLATE

## FITTING PROCEDURE

**NOTE:** Read the instructions thoroughly before starting

### OEM BUMPER REMOVAL

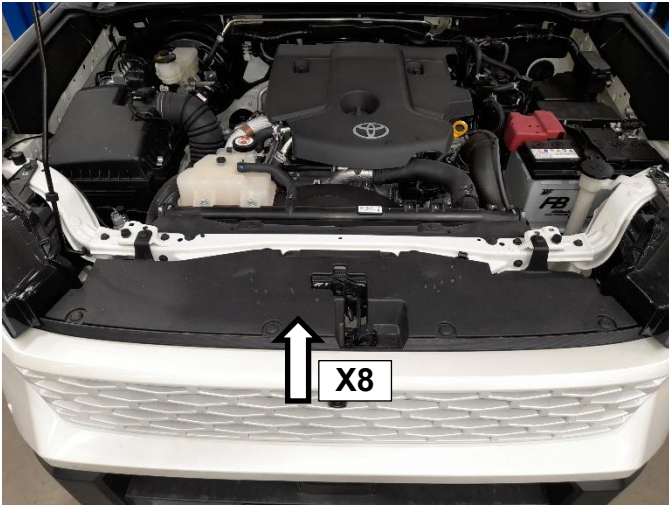

1. Open the bonnet and remove all scrivenets (8) retaining plastic cover. Set aside scrivenets removed for re-use later on. Remove plastic cover from above grille and set aside, this will be reused.

TIP: Depress centre to remove.

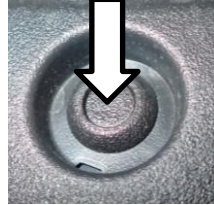

2. Remove all lower fasteners and scrivenets retaining bumper along inside edge of wheel arches – (Right hand side shown).

Leave the upper fasteners in place.



3. Remove all fasteners and scrivenets retaining bumper along lower lip.



4. Remove front mud flaps

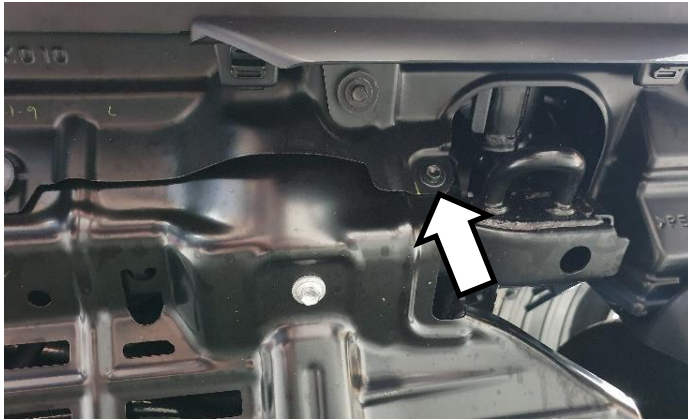

5. Remove bolt near the factory tow point as shown (LHS shown)



6. Remove dressing piece from underside of bumper and discard.

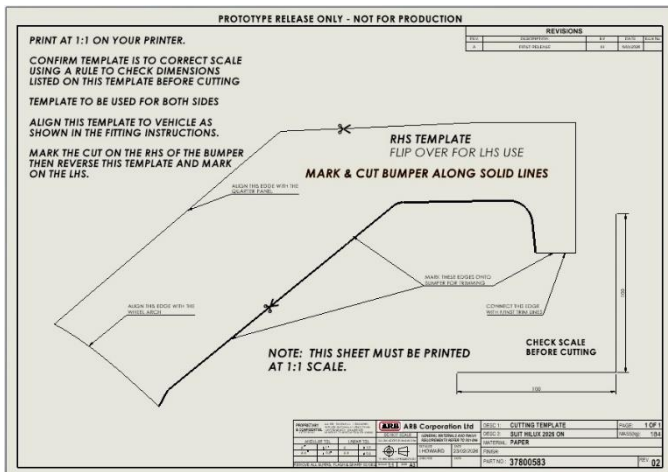

7. Carefully cut out flare/bumper cut template supplied.

***NOTE: Template will be used for both sides (LH & RH) – be careful not to damage.***



8. Stick masking tape onto flare at area underneath headlight running the tape well in towards the centre of the bumper.
  9. Position template onto the flare aligning with edges of bumper specified on template.
  10. Using a permanent marker, outline edges of bumper cut template onto masking tape where the flare and bumper cut will be performed.
- Remove template and repeat for LHS. Take care not to rip template upon removal.

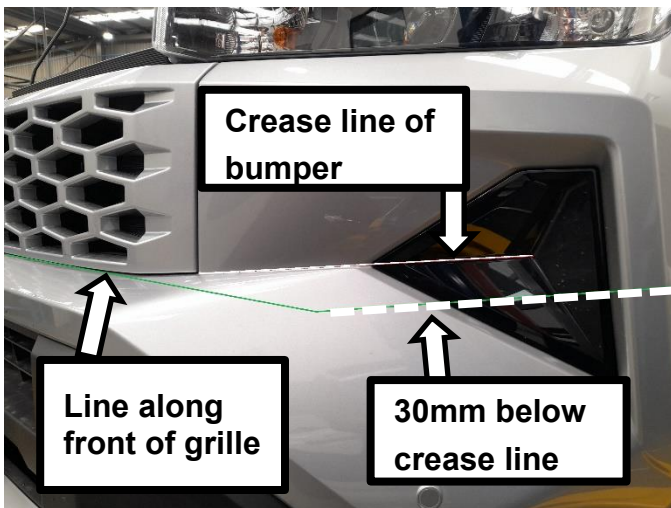

11. Mark a line along offset 10mm from the bottom edge of the grille. Extend this line out each side for approx 200mm.  
Measure 30mm below the crease line of the bumper and mark a parallel line.
  12. Using a ruler draw a continuous straight line from the edge of the cutting template to the line marked in the previous step. The template line will need to be extended down to meet the horizontal line.
- NOTE: A steel rule or tape measure can be used as a guide for marking out.***
13. Repeat above for LHS.

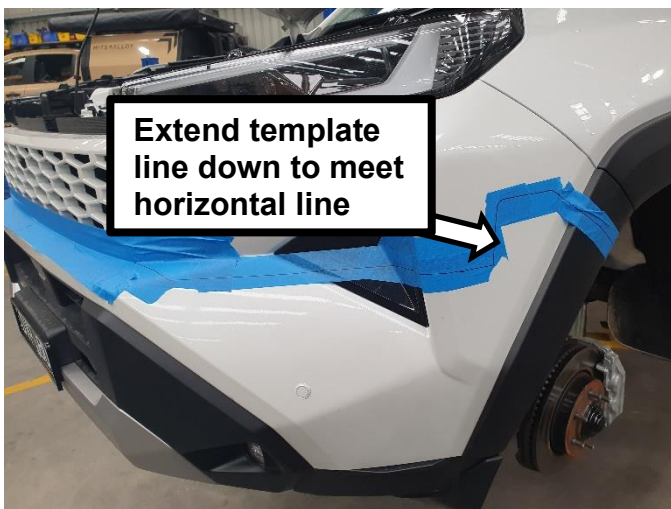

14. Final cut line should appear as shown, connecting to the templated cut on the flares



15. Carefully cut bumper along marked lines using an oscillating multitool.
16. Cut carefully on driver's side, so as not to damage the cable as shown. Once the bumper is cut, disconnect the cable.  
Repeat for LHS.
17. Discard lower bumper section after removing sensors/harness. this will not be reused



***WARNING: Cutting operations can result in flying debris, safety glasses should be worn.***

18. Removed lower section of bumper shown.





19. Mask off the bumper to protect from over spray and spray paint the internal body of the vehicle black or cover with self-adhesive vinyl.
20. Fit pinch weld to RH side along the cut edge on the flare. Carefully trim off any excess length.
21. Repeat on other side.



22. If vehicle is fitted with parking sensors, use a paint pen or white marker, label each parking sensor (Inner, outer, left or Right) prior to removing from bumper.  
  
Once marked, unclip parking sensors (2) from bumper and store for reuse.

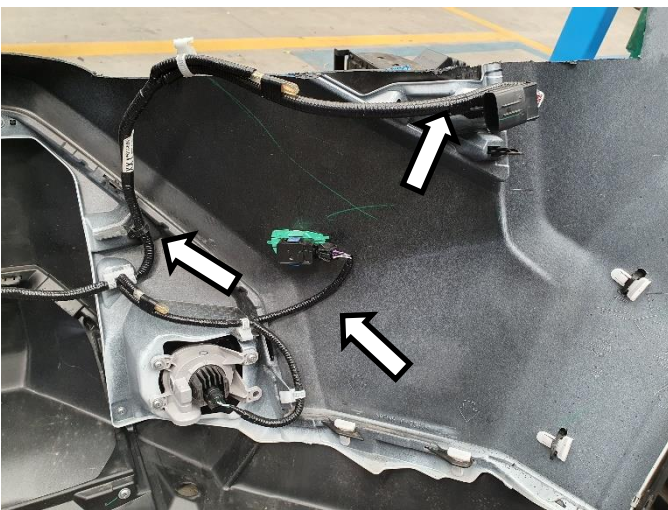

23. Remove harness from the lower bumper section. The fog lights will not be re-used.



24. Remove the radar module by removing the three screws holding the factory radar bracket in place.
25. Remove the radar from the factory bracket by unscrewing the remaining smaller three screws.  
  
Retain the radar and smaller screws for fitment in step 60.

***NOTE: Be very careful not to drop or damage the radar module.***



26. Remove plastic lower crash absorber from vehicle and discard.

***NOTE:*** Lower crash absorber is retained by plastic clips. Levering absorber free with a large screwdriver may aid removal.

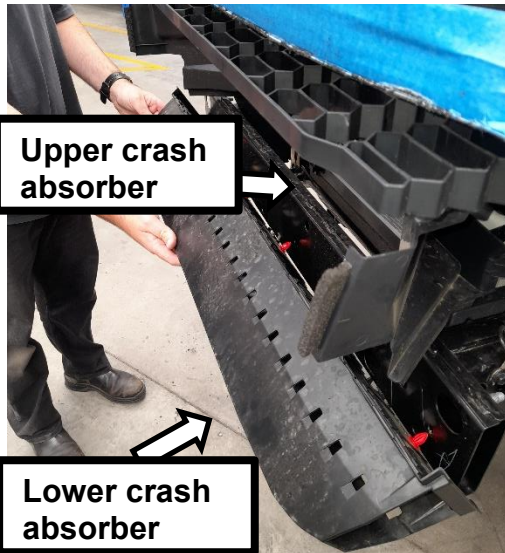

27. Remove bolts securing plastic upper honeycomb crush absorber from vehicle and discard.

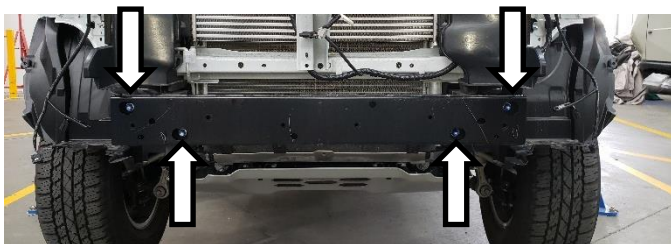

28. Remove two M10 bolts on both sides (4 total) fixing crash beam to chassis and remove crash beam.

Discard crash beam.

***NOTE:*** Retain four M10 bolts for reuse.

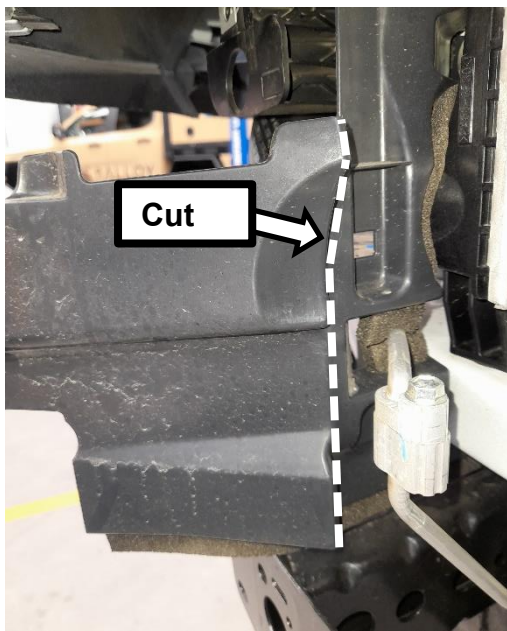

29. Locate air deflector panels and mark up as shown. Follow the corners of the panel. (Right Hand side shown).
30. Use an oscillating multitool or shears to carefully cut lower portion away and discard.

***NOTE: Take care not to damage any other components on the vehicle whilst cutting.***

31. Carefully remove any burrs or sharp edges with a file and/or sandpaper.

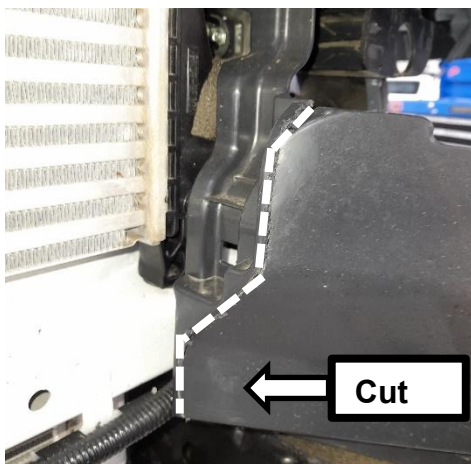

32. Repeat for LHS as shown.

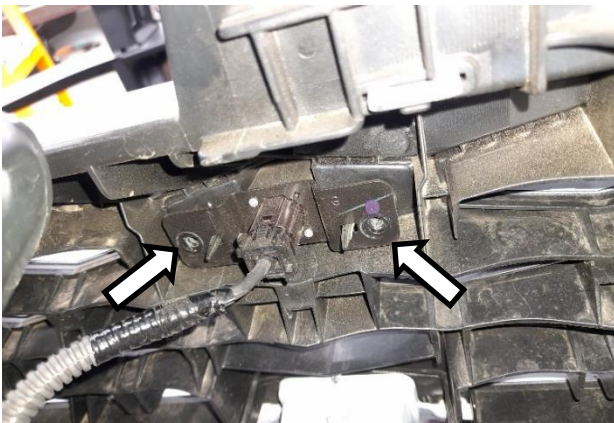

33. If not fitted with a camera, skip to step 39.
34. If fitted with a camera, unplug the camera from behind the grille, and remove the camera bracket from the grille by removing the two screws.
35. Remove the camera from the factory bracket by removing the two small screws. Retain the camera and two small screws for installation in step 56.



36. Remove camera cable/horn cable clip from vehicle body using a flat blade screwdriver or similar. Remove black tape from cables to allow full lengths.
37. Remove bolt securing passenger side horn. Discard bolt.



38. Relocate passenger side horn as shown. Secure with an M6x20mm button head bolt (supplied). This will allow full extension of the camera cable.



M6 - 9 Nm.

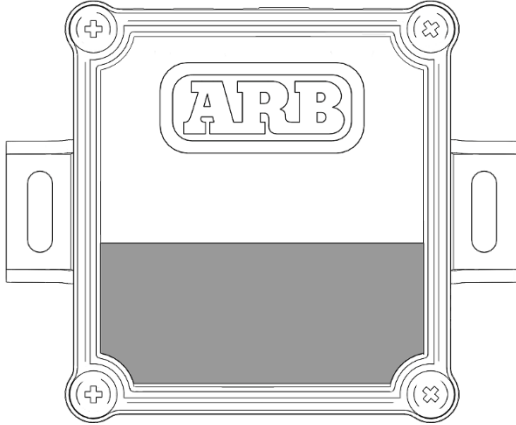

39. Identify the CANBUS Module (CANDEC), bull bar lighting harness (3501260), and patch harness (3514190).
40. Follow the fitting instructions included with the associated components.



41. Route cables through grommet as shown

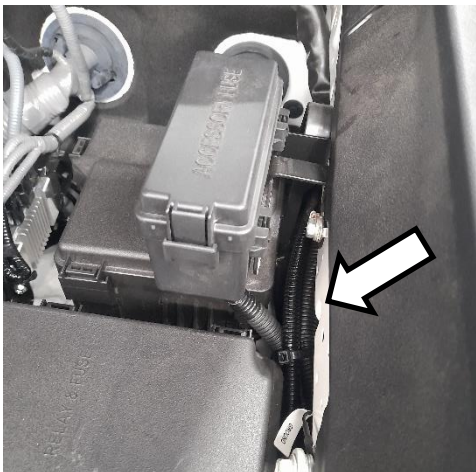

42. Route wiring along passenger side guard, and beside fuse box. Use cable ties to secure.

## CHASSIS MOUNT INSTALL

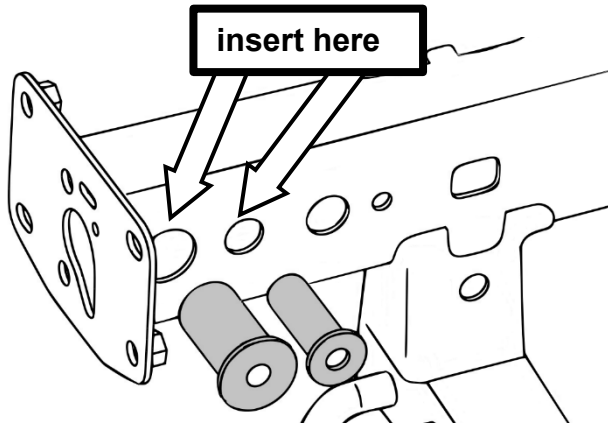

43. Insert two crush tubes into RHS chassis rail as shown.

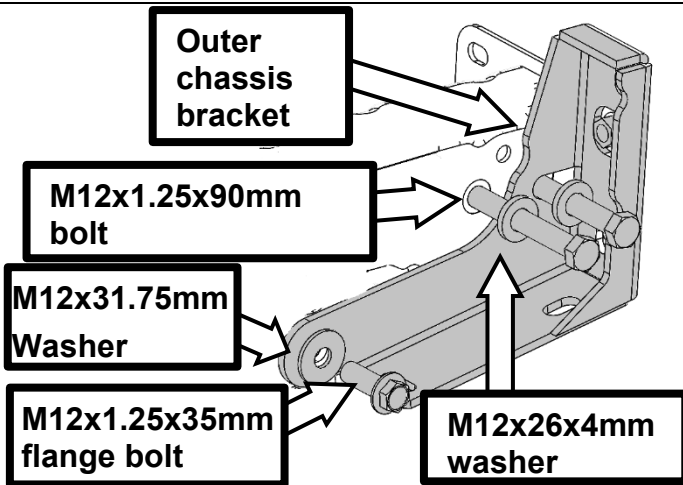

44. Loosely fasten RHS outer chassis support bracket to outside face of chassis using two M12x1.75x90mm flange bolts installed into the previously installed crush tubes.
45. Loosely fasten the RHS outer chassis support bracket at the rear hole using one M12x1.25x35 bolt and M12x31.75 flat washer installed into OEM captive nut in the chassis bracing.

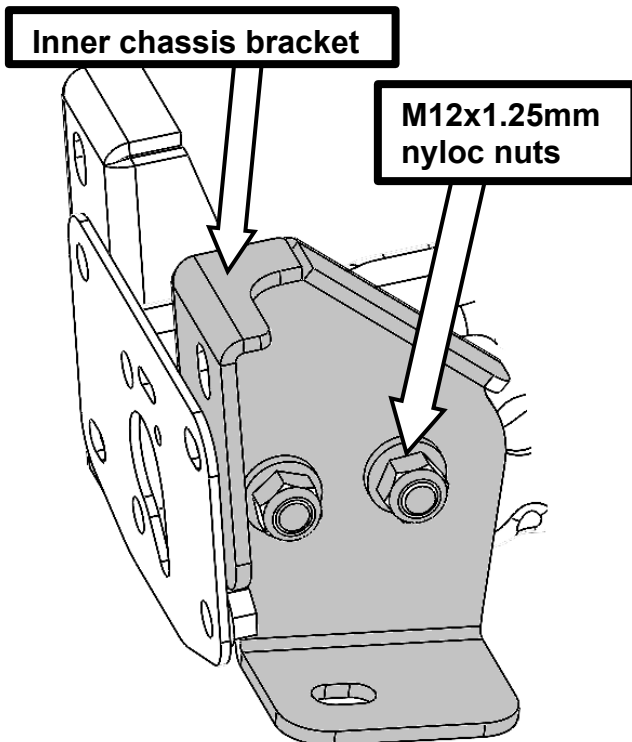

46. Loosely fasten RHS inner chassis support bracket to inside chassis face using two M12x1.25mm nyloc nuts and two M12x26x4 washers
47. Repeat process to install chassis support brackets on LHS

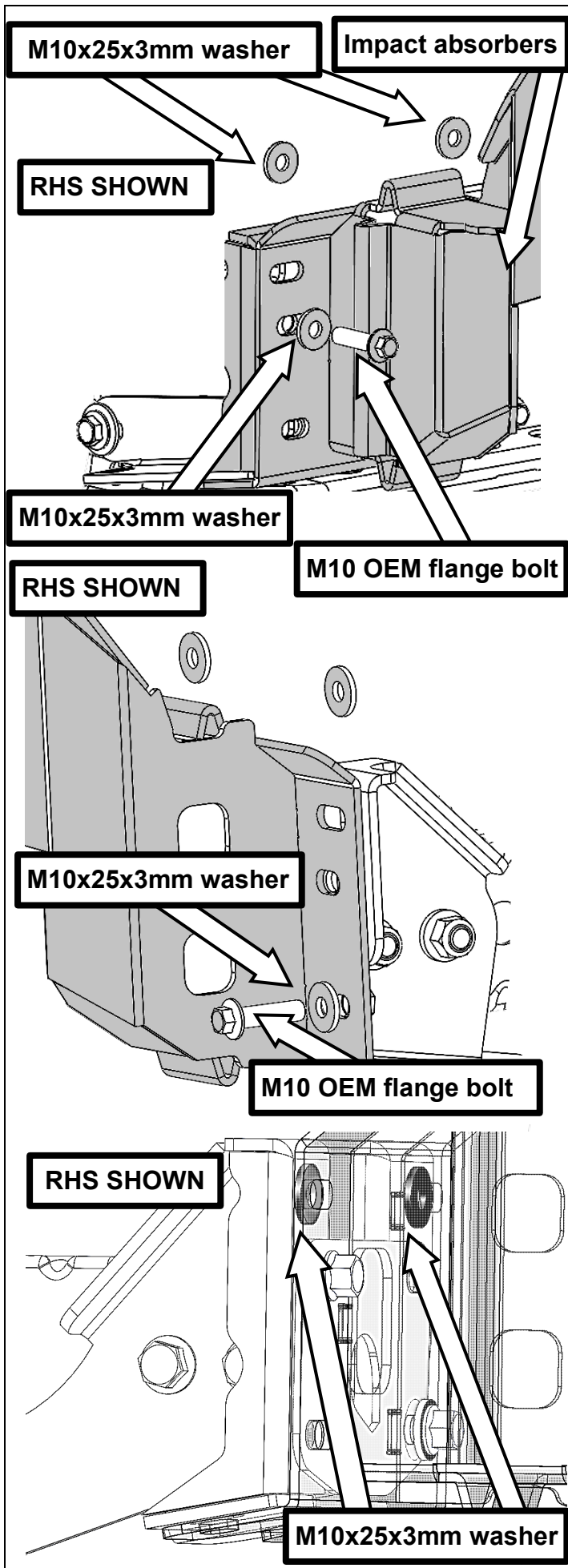

48. Loosely install the bull bar impact absorbers onto vehicle chassis flange by fastening two OEM M10 flange bolts (retained in step 14) and two M10x25x3mm flat washers into the chassis flange captive nuts.

**IMPORTANT**

49. Ensure two M10x25x3mm flat washers are installed inline with the top impact absorber slots, between the impact absorbers and rear chassis support brackets.

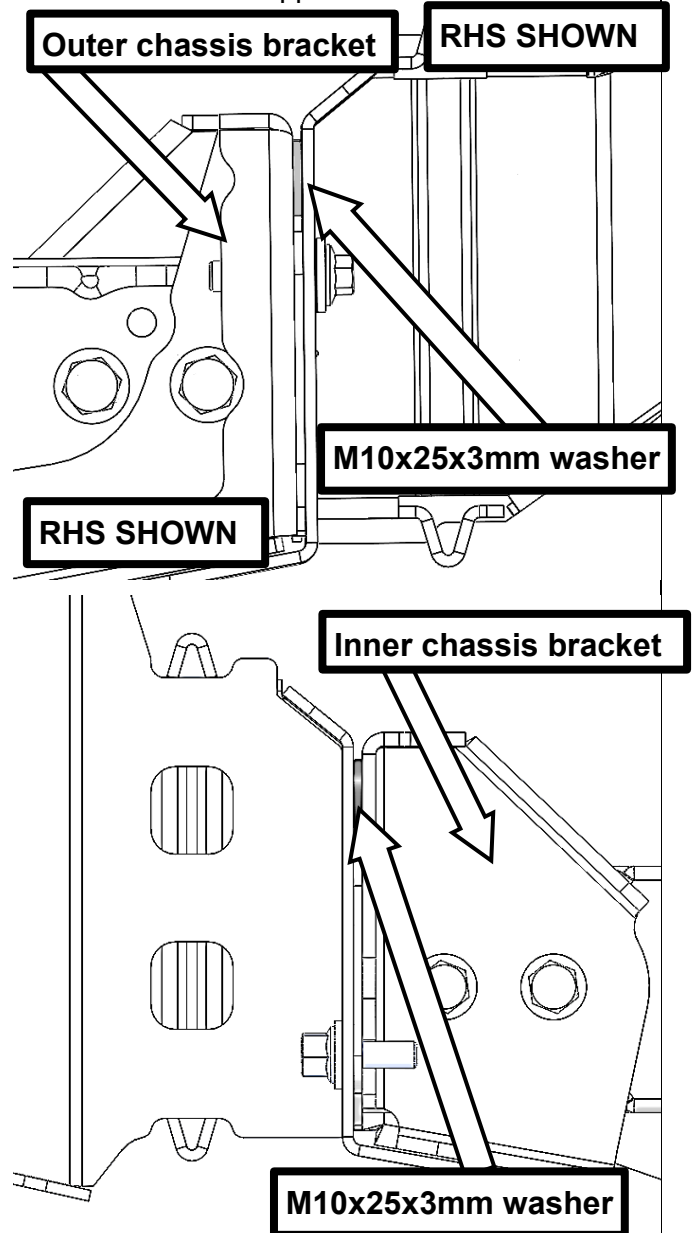

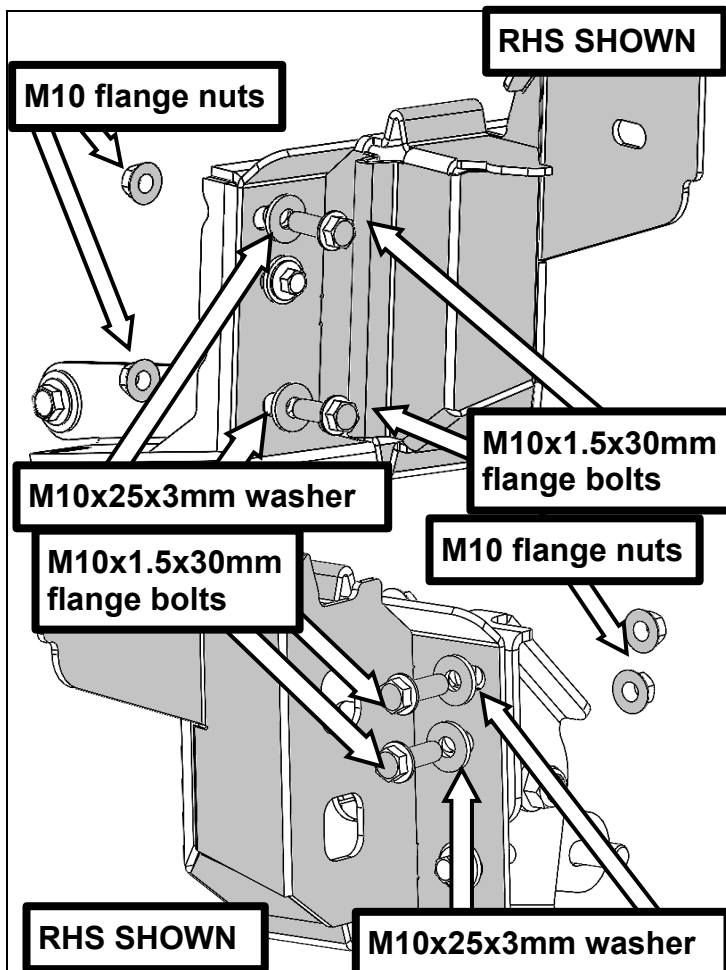

50. Loosely fasten four M10x1.5x30mm flange bolts, M10x25x3mm flat washers, M10 flange nuts through bull bar impact absorbers, chassis flange and rear chassis support brackets.

**NOTE:** *impact absorbers are handed. Ripples are on the outside of mounts.*

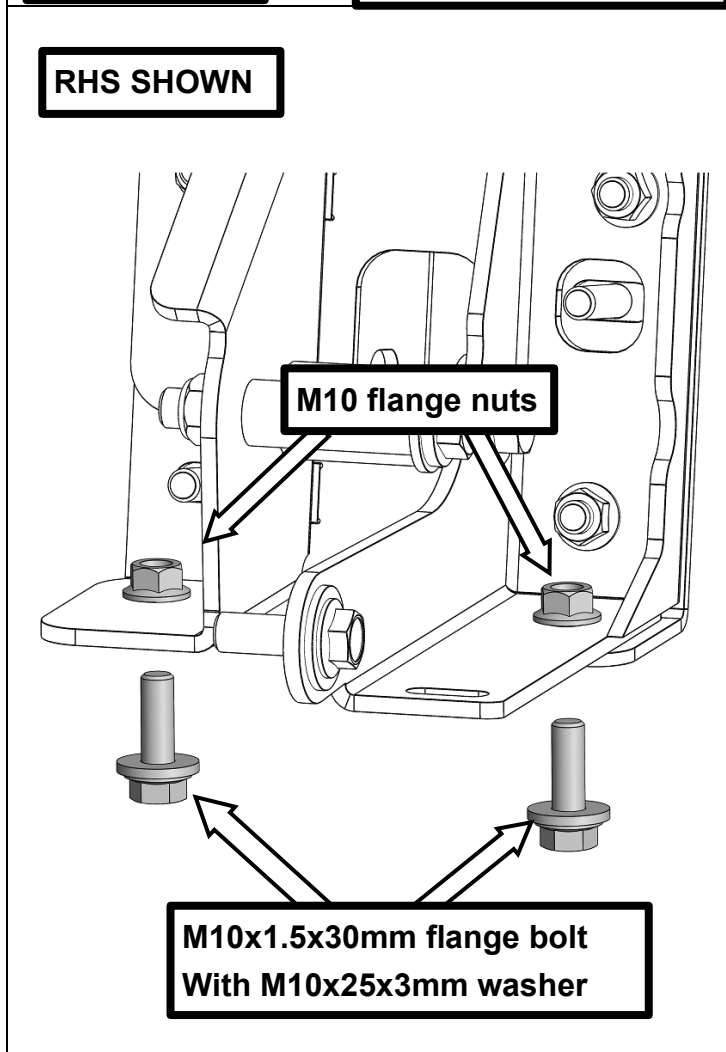
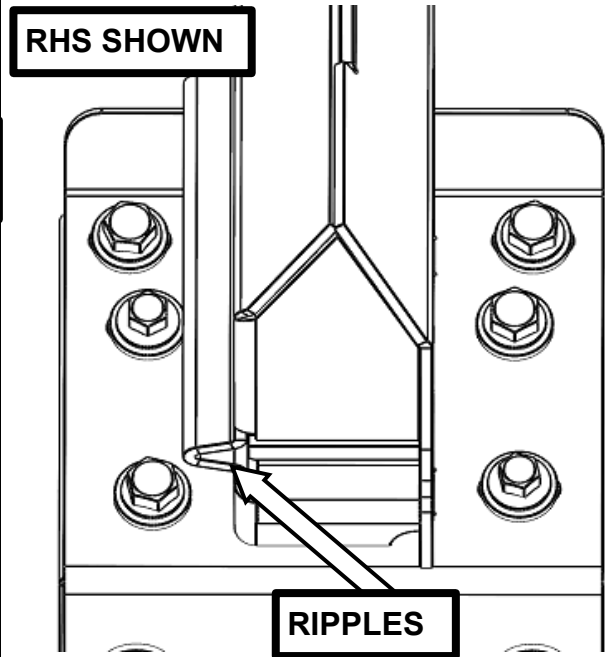

51. Loosely install two M10x30 flange bolts with a washer through lower slot of the impact absorbers and chassis support brackets into M10 flange nuts.

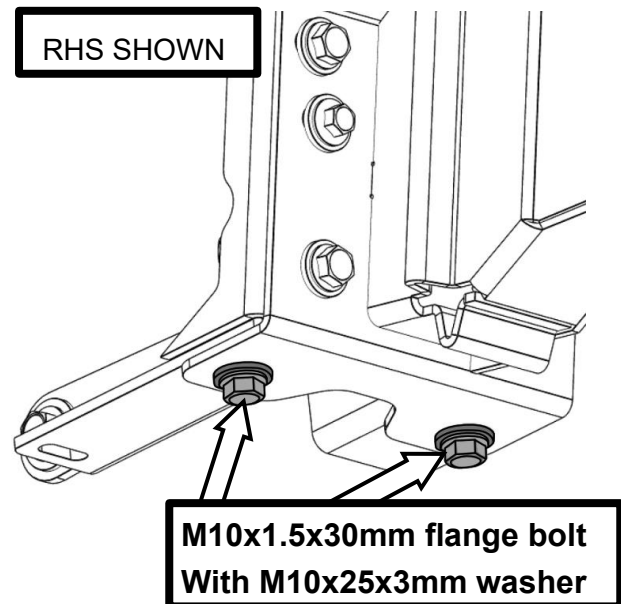

52. Repeat process to install impact absorbers on the LHS.

**NOTE:** *Starting with the M10 bolts installed from the front of the impact absorber, tighten all fasteners enough to eliminate any play in mount or support brackets but to still allow for adjustment of bull bar.*

## BULL BAR PREPERATION

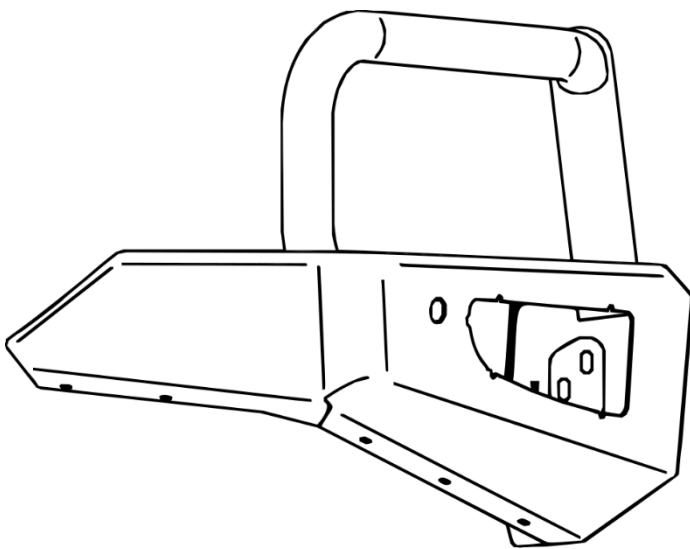
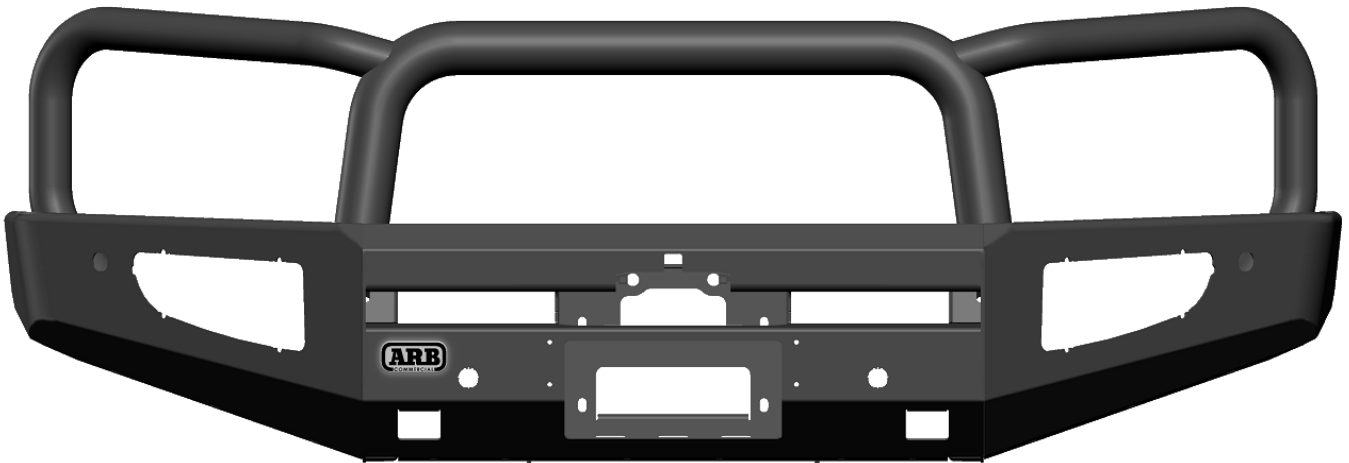

53. Clear space around the bull bar, ensuring that the bar cannot tip over while working on it.

These next steps require access to both the front and rear of the bull bar. Ensure that the bar is easy to manouvre while fitting components.

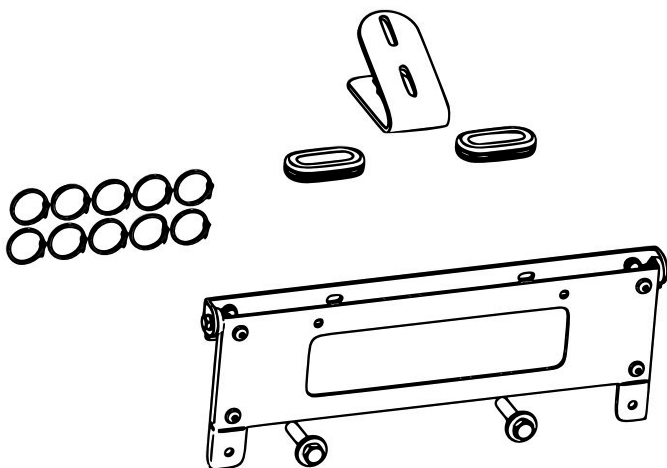

***NOTE:*** If fitting a winch proceed from here referring to instructions 3787989 found in winch fit kit 3540050, If not fitting a winch, skip to step 55.

54. Once the winch is fitted, please continue from step 55.

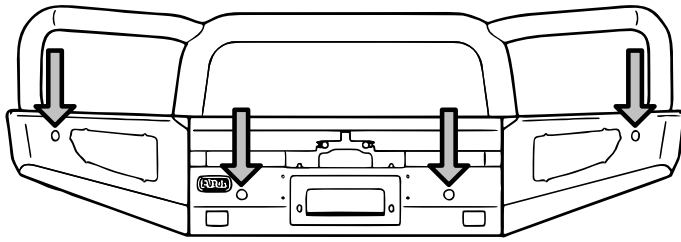

55. If car is fitted with parking sensors, fit the four sensors surrounds (part number 3525010) to the bar.

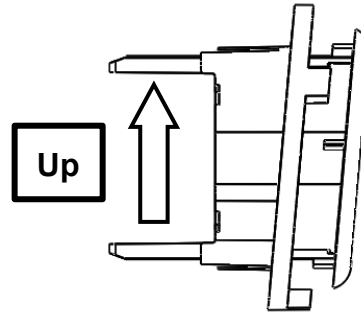

For models that are not fitted with parking sensors, fit the parking sensor blanks.

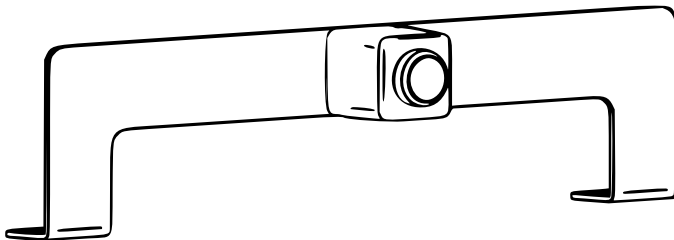
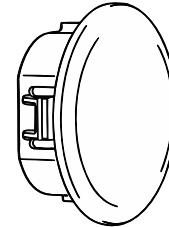

56. If fitted with a camera, fit the camera to the corresponding stainless steel 37501308 or 37501334 brackets using the small factory screws removed in step 35.
57. If vehicle is not fitted with a camera, identify the camera blanking plate.

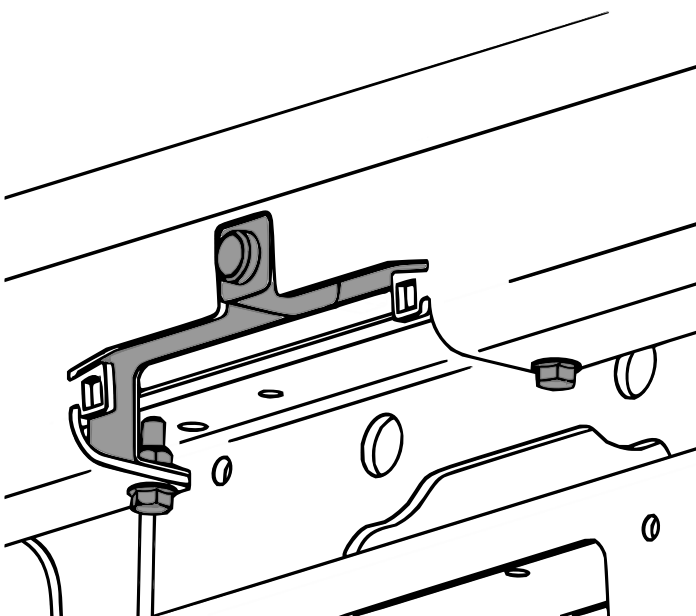
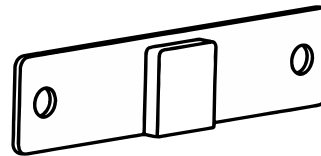

58. Fit the Camera bracket to bull bar using two M6 flange bolts, M6x16 washers and M6 Nyloc nuts to the centre of the bull bar.

***NOTE: Camera bracket should slide as far forward in the slots as possible, without the camera contacting the bull bar***

59. If camera is not fitted, attach the blanking plate with the two pieces of double sided tape, locating the part with an even gap around the top and sides of the protruding plate.

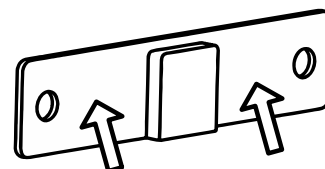

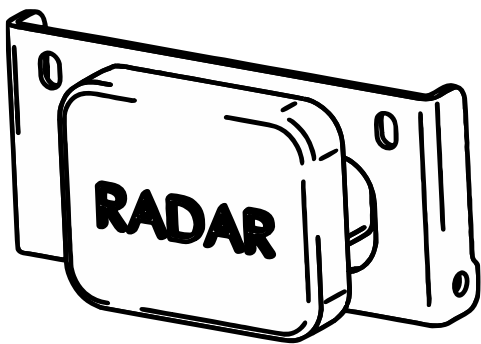

60. Fit Radar to bracket 37500327 using the factory hardware retained from step 25.

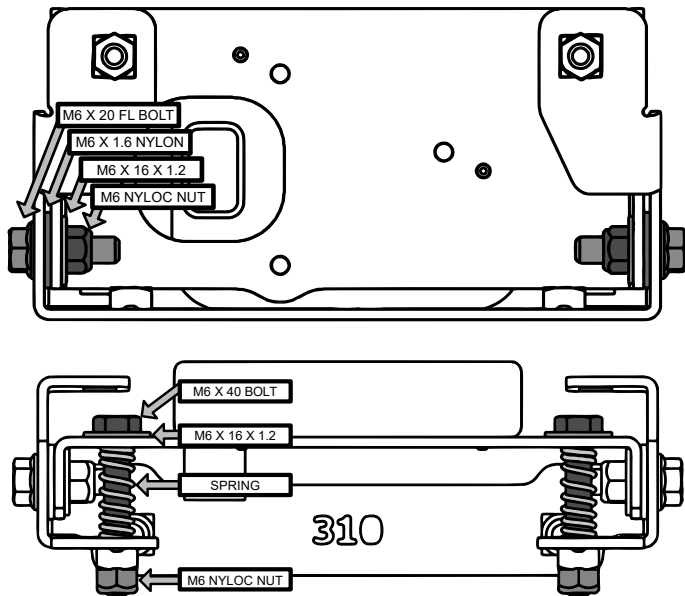
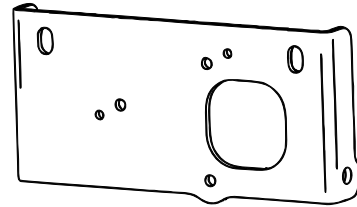

61. Assemble the two radar brackets together as shown on the left using:  
 two M6 x 20 Flange Bolts,  
 two M6 x 18 x 1.6 Nylon Washers,  
 four M6 x 16 x 1.2 Washers,  
 four M6 Nyloc Nuts,  
 two M6 x 40 Bolts, and  
 two springs.

**NOTE:** Do not overtighten the Nyloc nuts as this is used to adjust the angle of the radar.

The two Nyloc nuts on the 40mm bolts will be tightened once the bull bar is fitted to the vehicle.

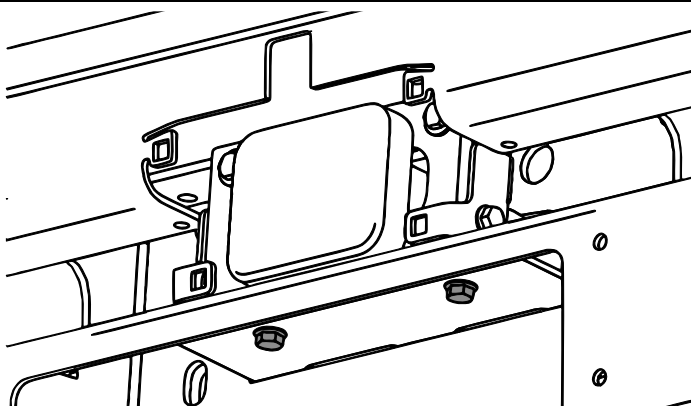

62. Attach the radar bracket assembly to the bull bar with two M6 x 20 Flange Bolts as shown.

Torque to specification.



M6 - 9 Nm.

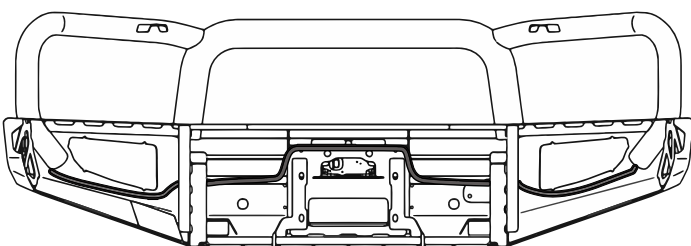

63. Thread the factory sensor wiring loom through the bull bar as shown, ensuring that the factory loom and sensors are in the same orientation and locations as fitted to the factory bumper.

Fix the loom to the bar with cable ties as required.

The end of the loom with the connector is on the RHS of the vehicle.

Ensure sensors are clipped into their housings and the rubber ring on the sensor isn't pinched from the front and ensure that the sensors and radar are connected.

**NOTE:** If fitting a winch, ensure cable is clear of the winch assembly.

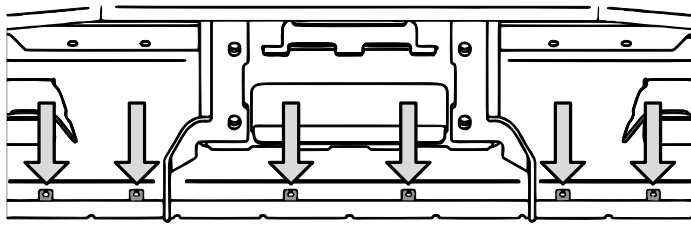

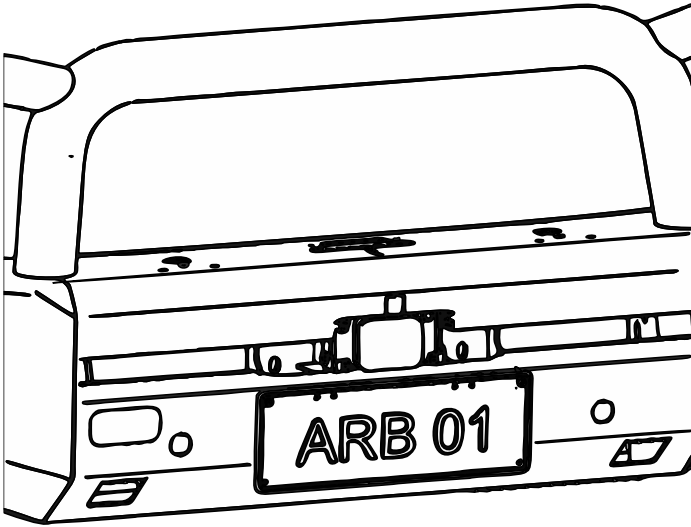

64. Attach six M6 cage nuts to the bottom of the bull bar as shown.

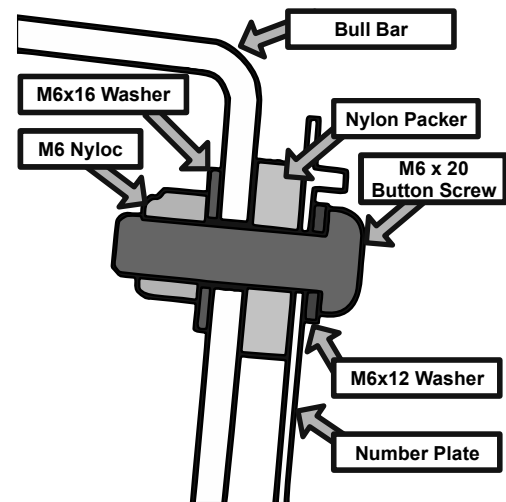

65. Attach the numberplate to the bull bar using the M6 x 20 button head screw, M6 x 12mm washer, nylon packer M6 x 16mm washer and M6 Nyloc Nut.

Torque to specification.



 M6 –9 Nm.

66. Fit any additional accessories such as antennas and driving lights, and the Bull Bar is ready to be fitted to the vehicle.

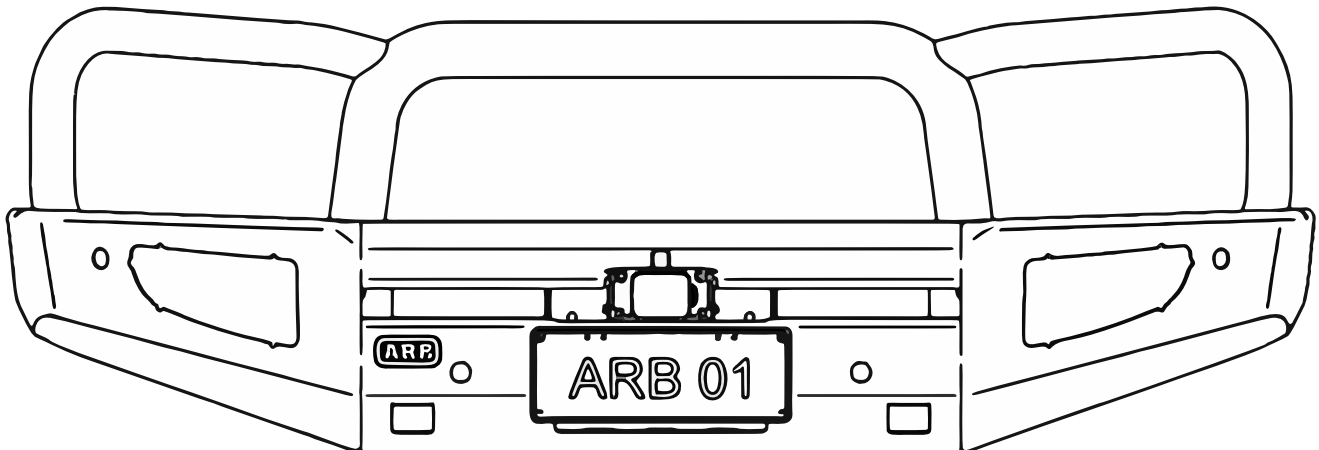

## BAR FIT TO VEHICLE

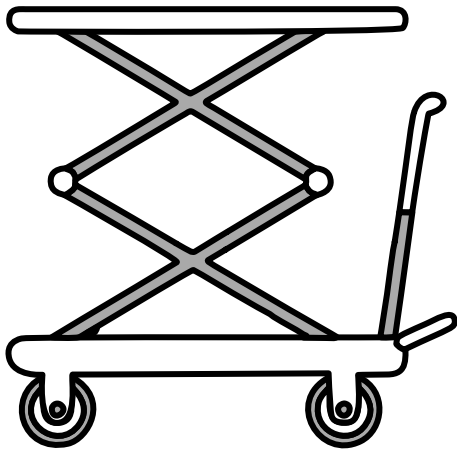

67. With the assistance of another person, move the bull bar close to the vehicle and offer the bull bar up to the vehicle mounts previously fitted in step 52.
68. If fitted with a camera, connect the camera to the cable behind the centre of the grille from step 36.

***WARNING: Due to the weight of the bar and winch if fitted, it is advised that you use some form of mechanical assistance when lifting the bar onto the vehicle such as an elevating trolley.***

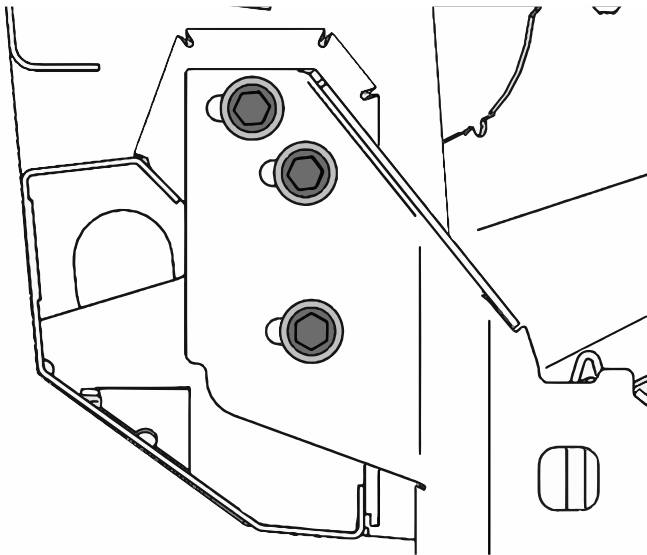

69. With the bull bar sitting in place, fit three M12 x 1.75 x 35 flange head bolts, M12 x 32 washers and M12 flange nuts per side. Leave finger tight for now.

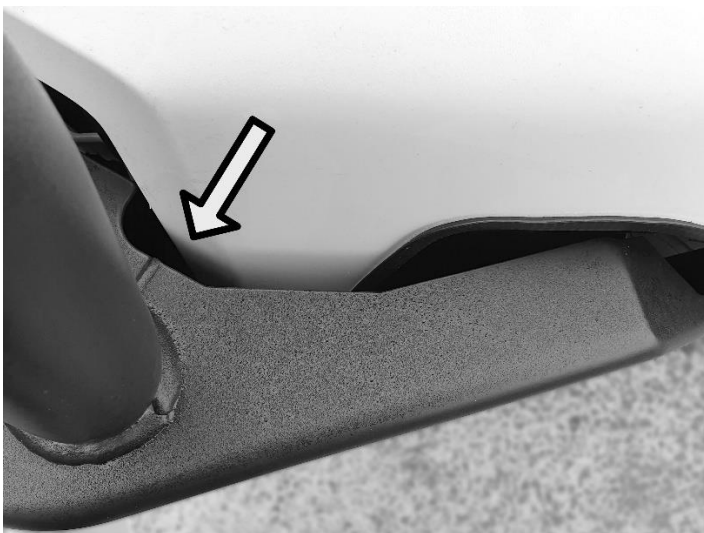

70. Ensure the bull bar has adequate gaps to the vehicle to allow for movement, with even and symmetrical gap between the rear edge of the wing and the body of the car.
71. Use the rear profile of the bull bar to check the position of the bull bar fitted left to right of the vehicle, there should still be movement in the mounts to shift the bar left to right.
72. The height of the bar shall be positioned approximately halfway through the hexagon row as shown below.





73. Align bull bar at the wing tips so that the rear face runs parallel with the bumper cut line and the lower rear face aligns with the end of the wheel arch.

Ensure the bar is positioned level on the vehicle

There should be a 20mm gap between the bull bar and the body, ensure both sides are symmetrical.

74. Tighten all the M10 bolts from step 52 on the chassis mounts to specification.



M10 – 44Nm.

75. Tighten the M12 chassis support bracket fasteners from step 44 to 47 to specification.



M12 – 77Nm.

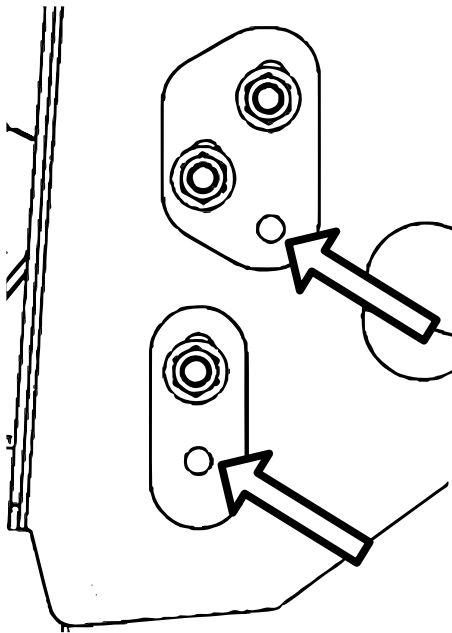

76. Once the bar adjustment is complete, torque the M12 bar mounting bolts to specification.



M12 – 77Nm.

77. Locate the pinning holes on either side of the bull bar.

Using the holes in the bull bar as a guide, drill the mounts with a Ø10mm drill bit.

78. Spray with a rust preventative coating.

79. Fasten with M10x1.5x30 flange bolts, M10 x 30 washers and M10x1.5 serrated flange nuts.

Torque to specification.



M10 – 44Nm.

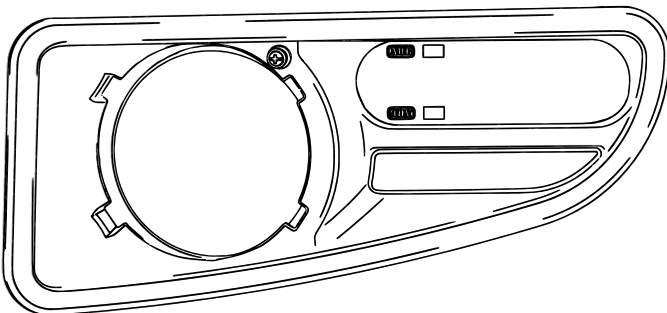

80. Assemble and install combination light surrounds (3163015) as per instructions supplied with surround kit.

81. Fasten the plastics to the cut outs in the bull bar.

**NOTE:** *Optional fog lamps can be installed at this point as per fitting instruction supplied with fog lamp kit.*

**HINT:** *Loosely fit top bracket to foglight surround, then insert into bull bar aperture. Fasten lower bracket, tighten all screws.*

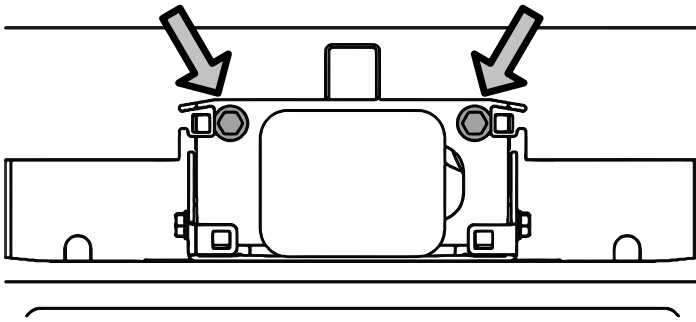

82. Using a digital level, ensure that the radar is perpendicular to the ground, adjust using the two bolts from the front face, tighten the locking nylocs on the rear of the bolts to lock in the position.

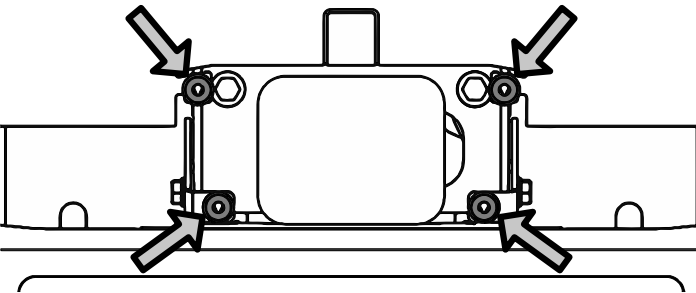

83. Attach the four plastic grommets to the front of the bull bar around the radar assembly and fasten the radar cover with the four PHD screws.

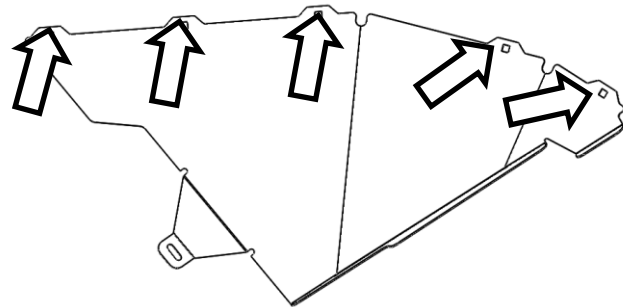
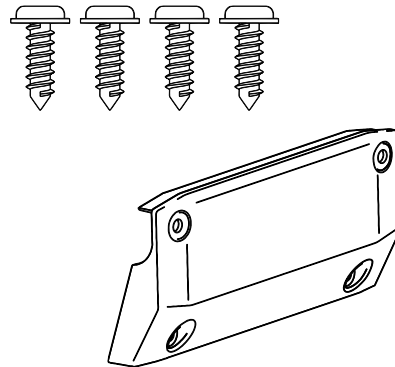

84. Fit five M6 cage nuts to each wing under panel.

**NOTE:** Cage nut heads to be located on top side.



85. Temporarily place the wing under panel in position, and mark lines onto the OEM inner guards (LH & RH) using lower edge of wing under panels as guide ensuring enough guard remains so that it may be neatly tucked/secured behind wing under panel lip.

**CAUTION:** Use care not to damage the windscreen washer bottle or hoses when trimming LH inner guard.

86. Carefully cut along marked lines using jig-saw or shears.

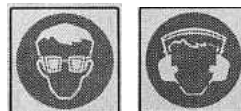

**WARNING:** Cutting operations can result in flying metal debris, safety glasses should be worn.

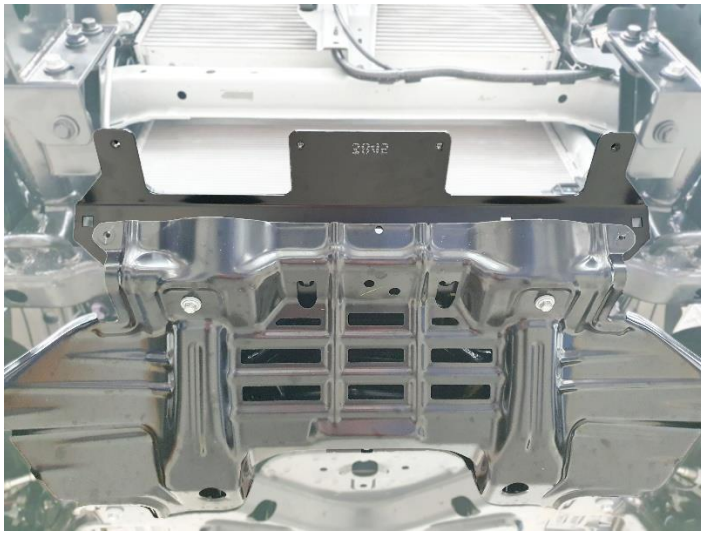

87. Remove factory bash plate and install rear under panel marked with '3845' using the 2x OEM M10 bolts.

Torque M10 Bolts to specification.



M10 – 44Nm

88. Re-install factory bash plate over the rear panel.

**RHS SHOWN**

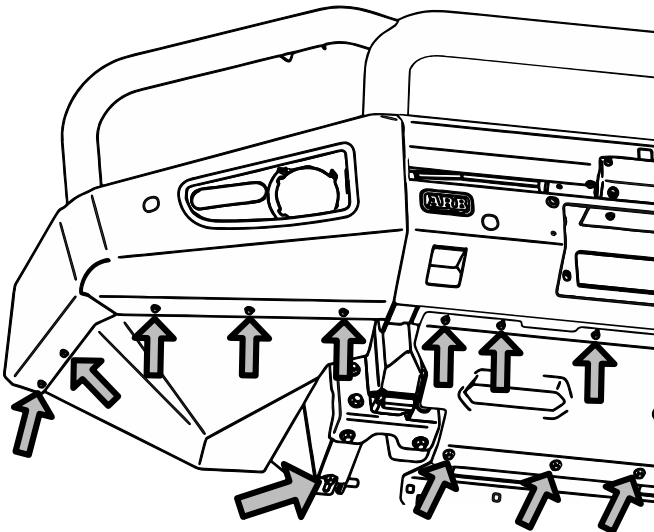

89. Fasten centre panel to rear panel using four M8 flange bolts and fasten to bar using 6x M6 button head screws

90. Fasten wing under panels to bull bar using ten M6 button head bolts.

91. Fasten lower corner of wing under panel using two M8x1.25x20mm flange bolts and M8 flange nuts

Torque to specification.



M6 – 9Nm



M8 – 22Nm

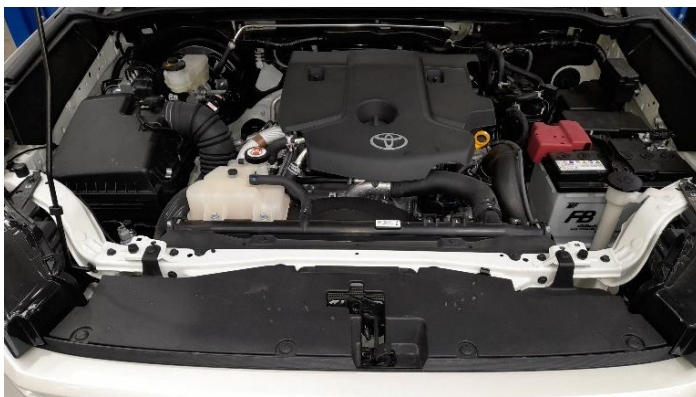

92. Re-install upper radiator cover panel and fasten using eight OEM scrivenets.

## FITTED PRODUCT

### NOTICE: ONCE BULL BAR IS FITTED:

- ◆ Ensure all bolts are tensioned correctly.
- ◆ All wiring is clear of sharp edges or moving surfaces and secured properly.
- ◆ Check operation of winch, if fitted.
- ◆ Check all wiring and connections to sensors, camera and radar are functioning correctly.
- ◆ Check the functionality of the indicators, parkers and fog lights if fitted.
- ◆ If fitted, test operation of parking sensors after fitment, misalignment of parking sensor to hole in bull bar may cause malfunction.

