



HARDLID FITTING INSTRUCTIONS

to suit

FORD RANGER 22+

VOLKSWAGEN AMAROK 23+

Instruction # 37800603

Ford Ranger 22+ Volkswagen Amarok 23+	Fitting Kit Part # 10057976
Compatible with Ford Models: Double Cab XL, XLT, XLS, Sport & Raptor	Not compatible Ford Models: Wildtrack, Space Cab & Single Cab
Compatible with VW Models: Double Cab Life, Style, Pan Americana	Not compatible VW Models: Aventura, Space Cab & Single Cab

IMPORTANT:

The J Brace has been specifically designed to further reinforce the vehicle tub when additional Accessories have been installed. The J Brace must be installed prior to a Canopy, Hard Lid, Electric and Manual cover, or anything that exceeds 45kg extending above the tub is installed.

FORD RANGER 22+ & VW AMAROK 23+ FITTING INSTRUCTION

READ INSTRUCTIONS CAREFULLY BEFORE COMMENCING THIS ACTIVITY.

To **maintain vehicle warranty**, the J Brace must be fitted for Ford Ranger 22+ and VW Amarok 22+

Ranger (Excl. Raptor) 2022 Part Number:
AMN1WJ27726AA / VN1WZ2627726A

Ranger Raptor 2022 Part Number:
AMN1WJ27726BA / VN1WZ2627726B

Volkswagen Amarok 2023 Part Number:
2HJ071776S EMD

Contact your local Dealer for information on the supply and installation of the reinforcement brackets.

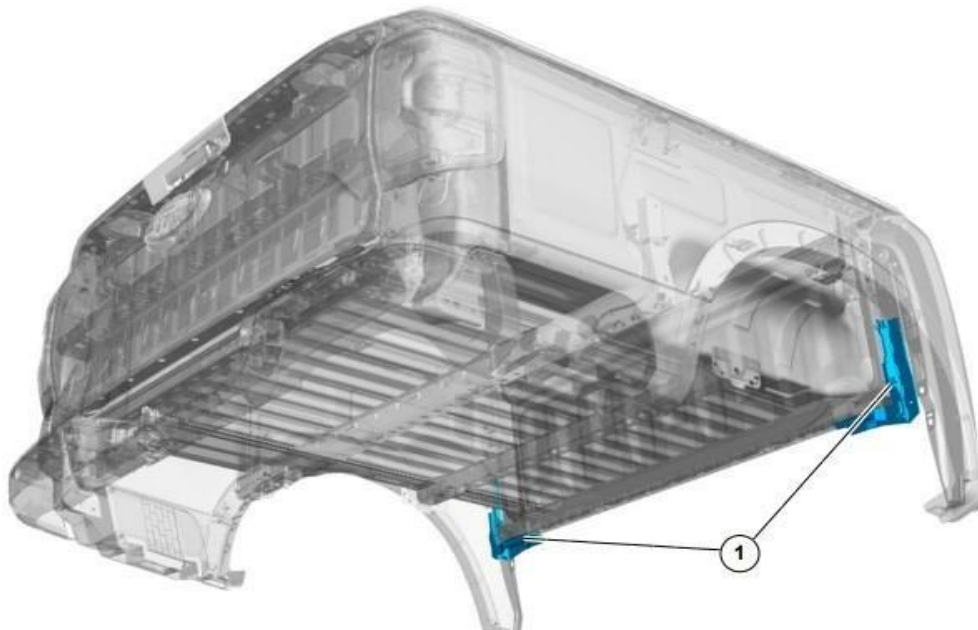

FORD RANGER 22+ & VW AMAROK 23+ FITTING INSTRUCTION

READ INSTRUCTIONS CAREFULLY BEFORE COMMENCING THIS ACTIVITY.

General Notes

To aid in installation the correct order of installation needs to be followed:

1. Install all electrical components first (1 of 2)
2. Install Vehicle Tub Sealing Kit
3. Install vehicle tub protective products such as tub liners*
4. Install styling bar onto HardLid
5. Install the HardLid Fitting Kit (2 of 2)
6. Install the HardLid (2 of 2)
7. Install any additional accessories such as roof racks.

**HardLid is compatible with under rail and Sport Guard style tub liners. Some trimming may be required. OEM liner compatibility cannot be guaranteed. Please contact your dealer for more information.*

- HardLid is supplied with 400N Gas Struts which are suitable for an unloaded lid. Recommended maximum loading of 25 kgs when opening the lid. If you require your lid to remain open whilst loaded, you will need to purchase A Heavy Load Strut Upgrade Kit which is available through your local dealer. Please use one of the following part numbers as a reference when contacting your dealer:

ARB NZ Part #	ARB AU Part #	Gas Strut N
10056207	176202	450N
10056209	176201	500N



- Read through the fitting instructions before installation of accessory.
- Check that the contents of the Fitting Kit are complete and undamaged.
- If any contents of the Fitting Kit are found incomplete or damaged, they must be replaced using the specified accessory components.
- Always install the accessory following the fitting instructions. Failure to do so may cause damage to the vehicle or the accessory and void the warranty.
- Ensure all recyclable discarded vehicle/accessory components and packaging are disposed following local recycling regulations.
- Safely store and protect any removed vehicle components.
- Ensure all bare metal surfaces are protected using Automotive Bare Metal Primer and touch-up paint.
- Remove all metal swarf and dust from all vehicle surfaces.
- Ensure all fasteners are torqued to the specifications as per instruction.
- Apply any adhesives to the vehicle only when the surface temperature is between 20°C to 40°C.
- **Bedliner:** Recommended rust preventative solution be applied to vehicle surfaces before installation.



General Vehicle and Accessory Warranty Notes and Cautions





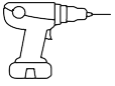

- For correct installation and proper operation of the vehicle and accessory we recommend this accessory is fitted by a qualified Technician.
- During the accessory fitment ensure all automotive safety practices and regulations are followed.
- Do not modify the vehicle in any way other than specified in these Fitting Instructions as this may void the warranty.

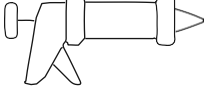
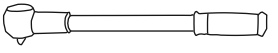

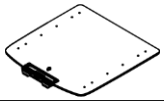
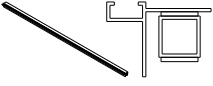

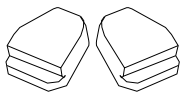

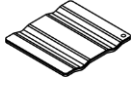
Safety Notes

- Check that all work practises comply with safety standards.
- It is advisable to seek assistance from another person when lifting heavy components.
- While using power tools ensure safe procedures are followed.
- Appropriate clothing & PPE must be worn.

TOOLS REQUIRED		
1	METRIC HEX KEY SET	
2	METRIC SPANNER SET	
3	CLEANING RAGS	

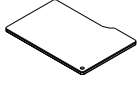
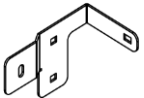
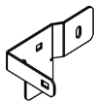





4	POWER DRILL & 5MM DRILL BIT	
5	METRIC RULER	
6	CLEAR NON-ACETIC SILICONE	
7	TROQUE WRENCH	





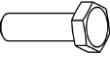
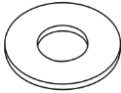

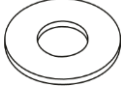
No	Part No.	QTY	Image
1.0	HARDLID	1	
2. SEALING KIT			
2.0	10057605 SEALNG CHANNEL	1	
2.1	10051996 3M PRIMER	2	
2.2	10051664 ALCOHOL WIPES	2	
2.3	10057892 TUB SEALING BLOCKS	1	
2.4	10054712 TAPE ANTI-ABRASION	1	
2.5	10055577 FOAM SEAL BLACK	0.2	
2.6	10058272 FRONT COVER (FORD ONLY)	2	
2.7	10058275 REAR COVER (FORD ONLY)	2	

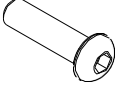
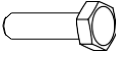
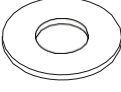
2.8	10058547 FRONT COVER (VW ONLY)	2	
2.9	10058554 REAR COVER RH (VW ONLY)	1	
2.10	10058553 REAR COVER LH (VW ONLY)	1	
3. MOUNTING BRACKETS & HARDWARE			
3.0	10057118 MOUNTING BRKT FRONT LH	1	
3.1	10057719 MOUNTING BRKT FRONT RH	1	
3.2	10057723 MOUNTING BRKT FRONT CMS	2	
3.3	10057722 MOUNTING BRKT CENTRE CMS	2	
3.4	10057724 MOUNTING BRKT CENTRE	2	
3.5	10057729 MOUNTING BRKT REAR LH	1	

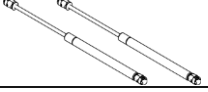
FORD RANGER 22+ & VW AMAROK 23+ FITTING INSTRUCTION

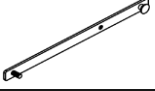
READ INSTRUCTIONS CAREFULLY BEFORE COMMENCING THIS ACTIVITY.

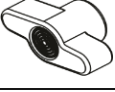





3.6	10057730 MOUNTING BRKT REAR RH	1	
3.7	10057737 SPACER M8 x 18 x 13mm	6	
3.8	10057890 SPACER M8 x 18 x 10mm	2	
3.9	10057891 SCREW - HEX HD M6 x 20	6	
3.10	10053451 WASHER - FLAT M6 x 19 x 1.6	12	
3.11	10053338 NUT - NYLOC M6	6	
3.12	10053451 WASHER - FLAT M6 x 19 x 1.2	44	
3.14	10053337 NUT M8 NYLOC	14	
3.15	10052186 SCREW B/HEAD M8X35MM	14	
3.16	10056261 SET SCREW M8X30MM	12	
3.17	10055714 WASHER FLAT M8X24X2MM	2	

4. GAS STRUTS			
4.0	10058202 GAS STRUT PAIR	1	
<p>HardLid is supplied with 400N Gas Struts which are suitable for an unloaded lid. We recommend a maximum loading of 25 kgs when opening the lid. If you require your lid to remain open whilst loaded, you will need to purchase a Heavy Load Strut Upgrade Kit which is available through your local dealer- refer to user manual for part number information.</p>			
5. MOUNTING RAILS			
<p>Note: Items 5.2~5.8 are pre-assembled as part of 5.0 & 5.1 Ensure that sub-assemblies contain all the parts before commencing installation.</p>			
5.0	10057978 VCR ASSY LH FOR RANGER 22+	1	
5.1	10057979 VCR ASSY RH FOR RANGER 22+	1	
5.2	10055552 HINGE MOUNT	1	
5.3	10055553 GRUB SCREW M8 x 10	1	
5.4	10000100 KNOB FEMALE WING M8	1	
5.5	10003717 WASHER FLAT M8X24X2MM	2	
5.6	10059215 STRIKER ASSY RH (PRE-ASS'D)	1	

FORD RANGER 22+ & VW AMAROK 23+ FITTING INSTRUCTION

READ INSTRUCTIONS CAREFULLY BEFORE COMMENCING THIS ACTIVITY.

5.7	10059214 STRIKER ASSY LH (PRE-ASS'D)	1	

7.3	10055927 STEP SPACER	2	
7.4	10055714 WASHER M8X24X2MM	2	
7.5	10000091 SEAL	0.2	
7.6	10055835 NUT HEX FLANGE M8	2	
7.7	10053982 RIVET BLACK	8	
10. MISCELLANEOUS			
8.0	10055862 OWNERS MANUAL	1	



6. HINGES

Note: Items 6.2~6.4 are pre-assembled as part of 6.0 & 6.1

Ensure that sub-assemblies contain all parts before commencing installation.

6.0	10057826 LEFT HINGE ASSEM	1	
6.1	10057827 RIGHT HINGE ASSEM	1	
6.2	10056199 NUT M8 NYLOC	4	
6.3	10056204 BALL STUD	4	
6.4	10003717 WASHER FLAT M8X19X1.2MM	4	

7. General Hardware

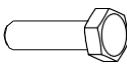
7.0	10053299 M8X30MM B/HEAD	6	
7.1	10003717 WASHER M8X19X1.2MM	6	
7.2	10056261 M8X30MM SETSCREW	2	

FORD RANGER 22+ & VW AMAROK 23+ FITTING INSTRUCTION

READ INSTRUCTIONS CAREFULLY BEFORE COMMENCING THIS ACTIVITY.

OEM Bedliner Preparation

It is recommended the bedliner is removed from the vehicle before commencing the modifications.
If the vehicle is equipped with CMS mount rails these will also require removal.

- Using the corner radius as a guide, cut approximately 30mm down from the top of the corner.
- Repeat for opposite side.

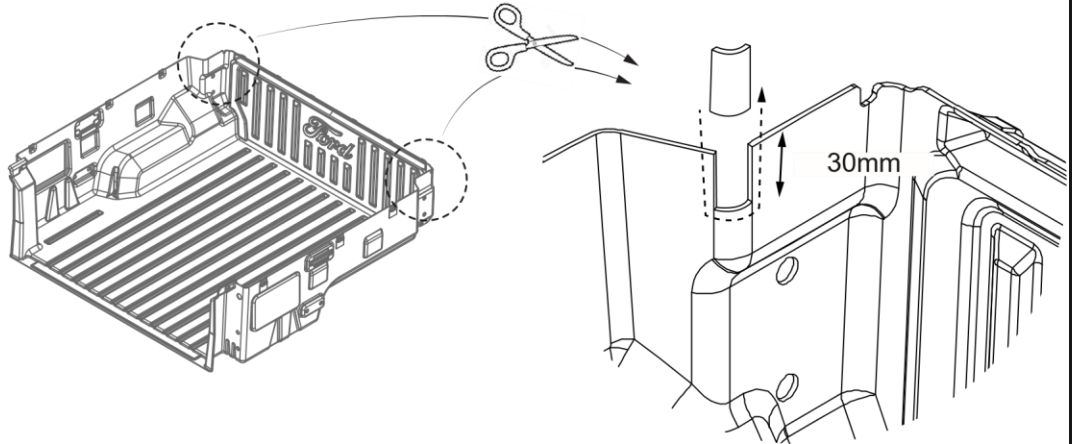

- Mark a centre point 90mm backward from the front wall and 54mm down from the top edge.
- Drill a 20mm hole.
- Repeat for opposite side.
- Debur all cut edges.

Do not reinstall the liner or CMS mount rails until the sealing (refer steps 1-7) and electrical wiring (10058093) have been installed.

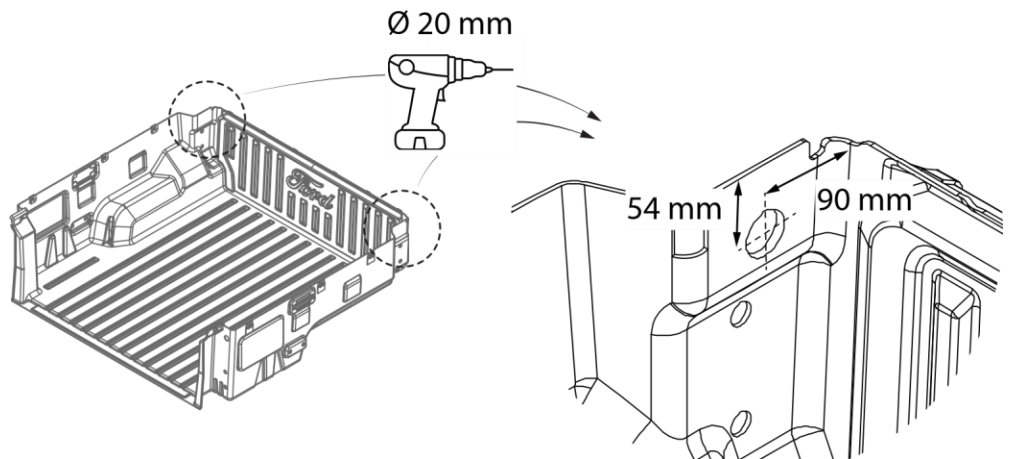

FORD RANGER 22+ & VW AMAROK 23+ FITTING INSTRUCTION

READ INSTRUCTIONS CAREFULLY BEFORE COMMENCING THIS ACTIVITY.

Sportguard Preparation

It is recommended the Sportguard is removed from the vehicle before commencing the modifications.
If the vehicle is equipped with CMS mount rails these will also require removal.

- Using the corner radius as a guide, cut approximately 15mm down from the top of the corner.
- Repeat for opposite side.

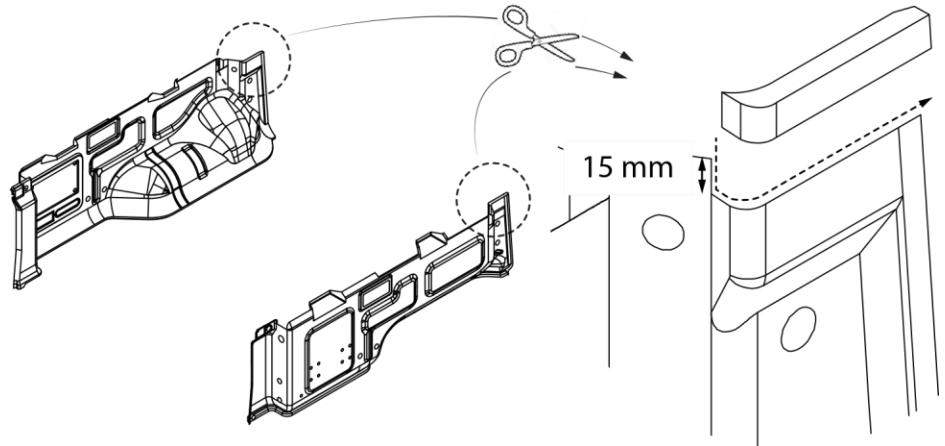

- Locate the formed crosshair on the Back surface.
- Drill a 20mm hole.
- Repeat for opposite side.
- Debur all cut edges.

Do not reinstall the liner or CMS mount rails until the sealing (refer steps 1-7) and electrical wiring (10058093) have been installed.

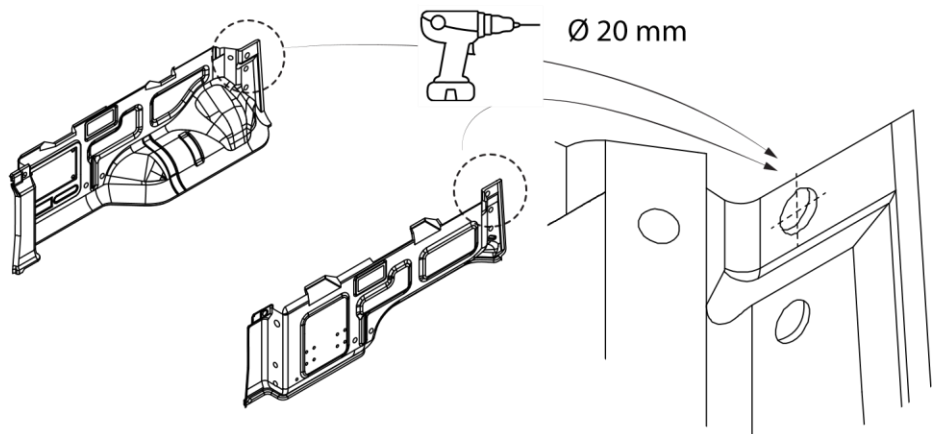

FORD RANGER 22+ & VW AMAROK 23+ FITTING INSTRUCTION

READ INSTRUCTIONS CAREFULLY BEFORE COMMENCING THIS ACTIVITY.

Vehicle Preparation

- Carefully measure and mark a 30 X 150MM section at the front lower corner of the plastic rail cap.
- Remove and discard the cut section to expose the M8 threaded hole. Repeat for opposite side.

Note: dependant on vehicle model this step may not be required.

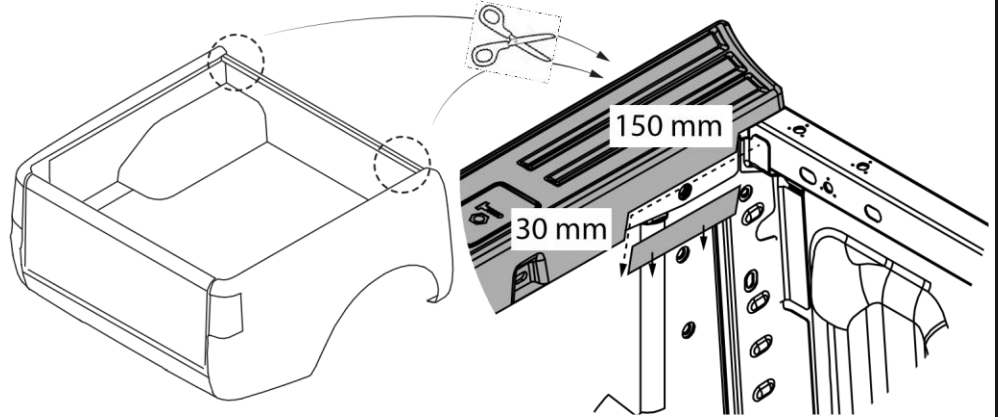

- Using the rear, bottom corner of the plastic cap as a datum (identified by arrow and the X), measure and mark the two positions shown.
- Carefully drill 2 X 20mm holes into the **plastic cap only**.
- Repeat process for opposite side.

Take care not to damage the vehicle.

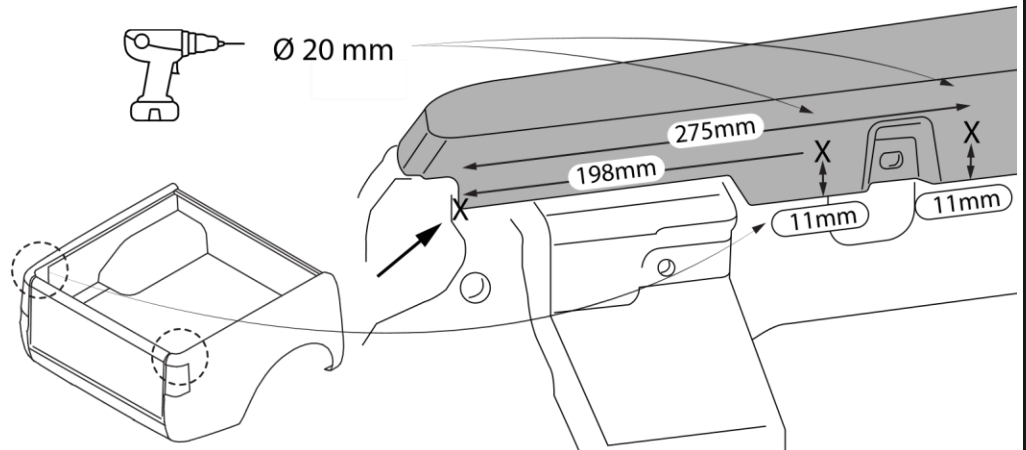

FORD RANGER 22+ & VW AMAROK 23+ FITTING INSTRUCTION

READ INSTRUCTIONS CAREFULLY BEFORE COMMENCING THIS ACTIVITY.

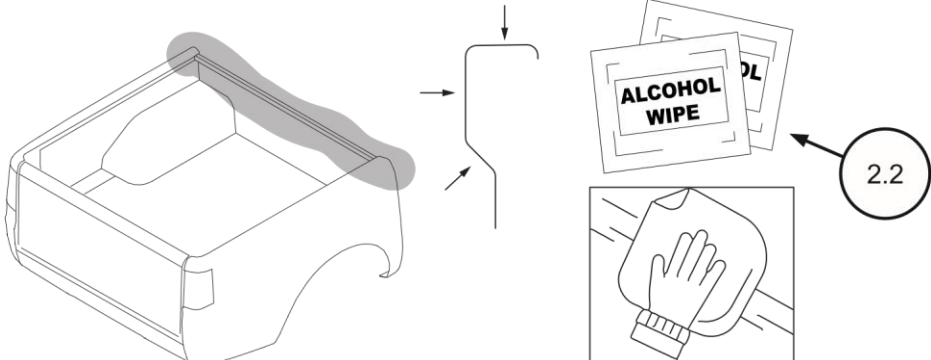
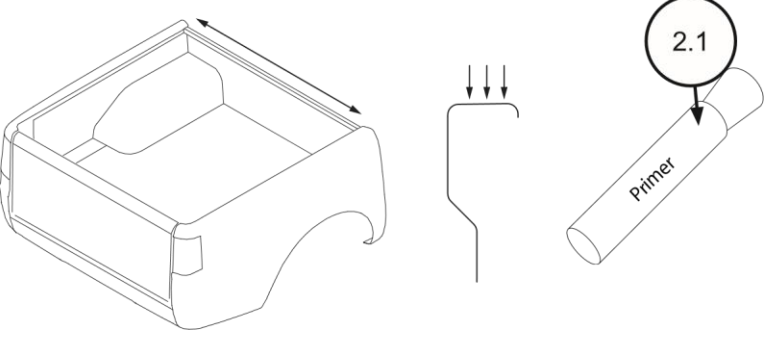
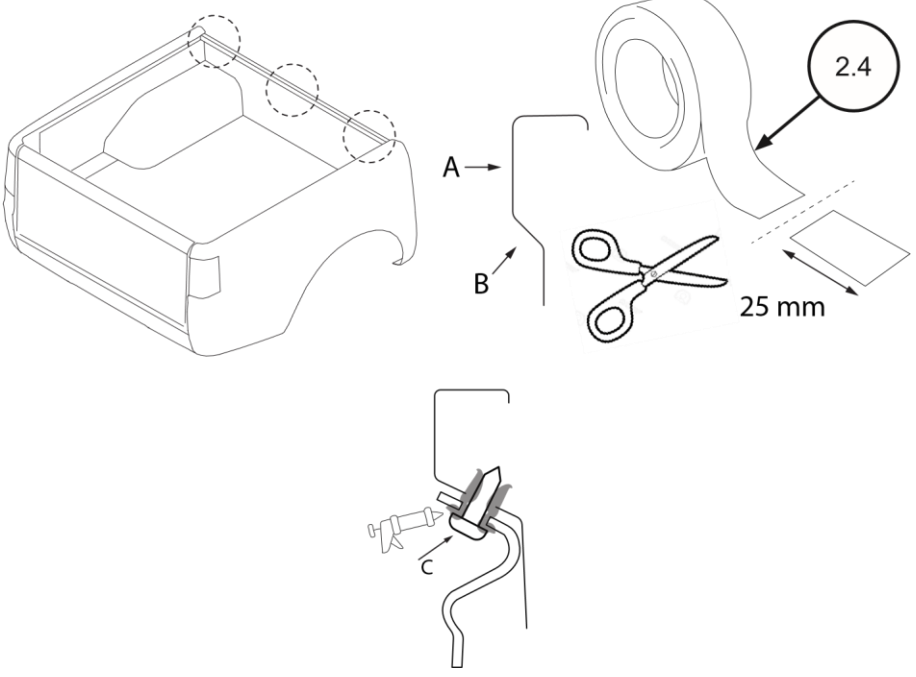
<p>Step 1</p> <ul style="list-style-type: none"> Thoroughly clean the top rear and underside of the front rail using alcohol wipes. Thoroughly clean the upper front corners of the deck using alcohol wipes. 	
<p>Step 2</p> <ul style="list-style-type: none"> Apply 3M primer, item 2.1 to the entire length of the top surface of the front rail. 	
<p>Step 3</p> <ul style="list-style-type: none"> Cut 5 x 25mm strips of tape, item 2.4 and cover the 5 holes along the inside face of the front rail indicated by arrow A. <p>Do not cover the threaded holes.</p> <ul style="list-style-type: none"> If there is no bedliner fitted, use the remaining tape to cover the 6 holes located on the underside face indicated by arrow B. If there is a liner installed, silicone will need to be applied to the plastic fasteners that hold the front wall in the position indicated by arrow C. 	

FORD RANGER 22+ & VW AMAROK 23+ FITTING INSTRUCTION

READ INSTRUCTIONS CAREFULLY BEFORE COMMENCING THIS ACTIVITY.

Step 4

1. Cut the foam seal item 2.5 into 2 x 80mm strips.
 2. Locate the cavities at the front corners underneath the plastic rail cap.
 3. Push the foam seal into the cavity and repeat for the opposite side.
- Gently lift the inside front corner of the plastic rail cap and fill the internal void with a generous amount of silicone. Refer detail A.
 - Let the rail fall back to its natural resting point, fill any areas between the vehicle metal work and plastic rail cap with silicone. Refer detail B.
 - Install the drip seal mounting channel, item 2.0
 - Fill the areas between item 2.0 and the vehicle side rails with silicone.

Steps 1-3 not applicable for VW Amarok

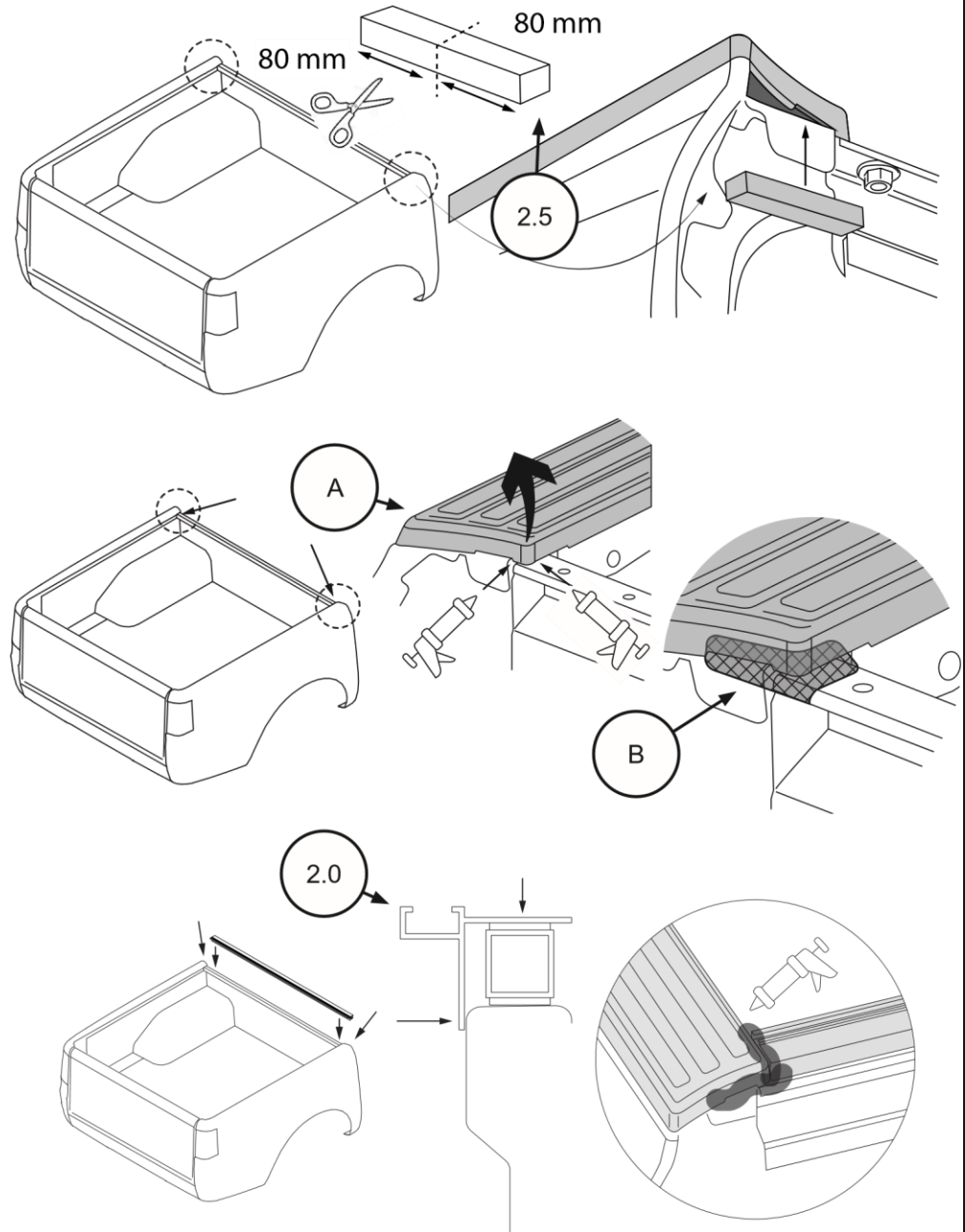

FORD RANGER 22+ & VW AMAROK 23+ FITTING INSTRUCTION

READ INSTRUCTIONS CAREFULLY BEFORE COMMENCING THIS ACTIVITY.

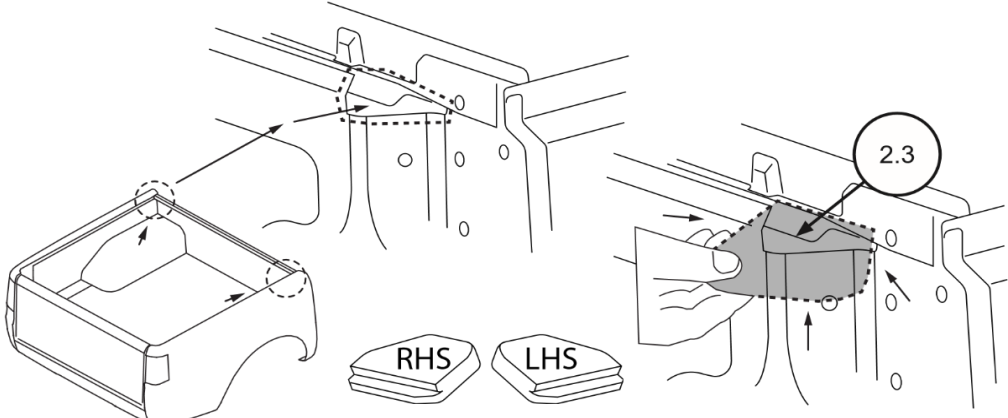
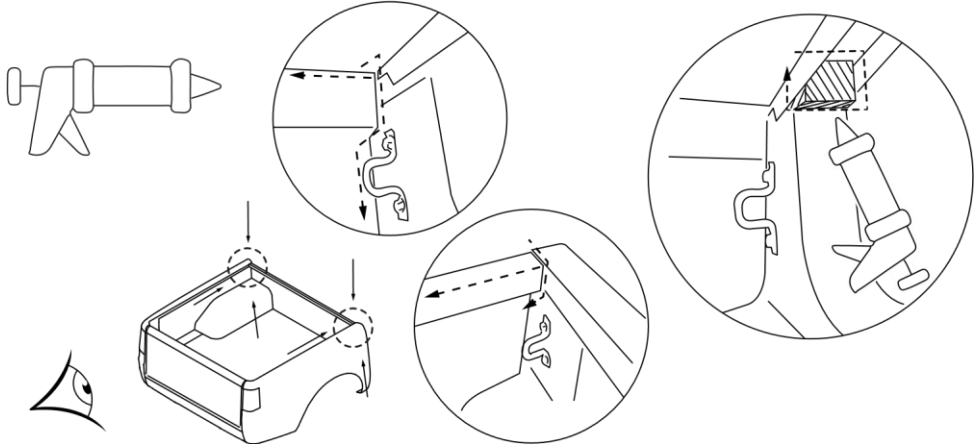
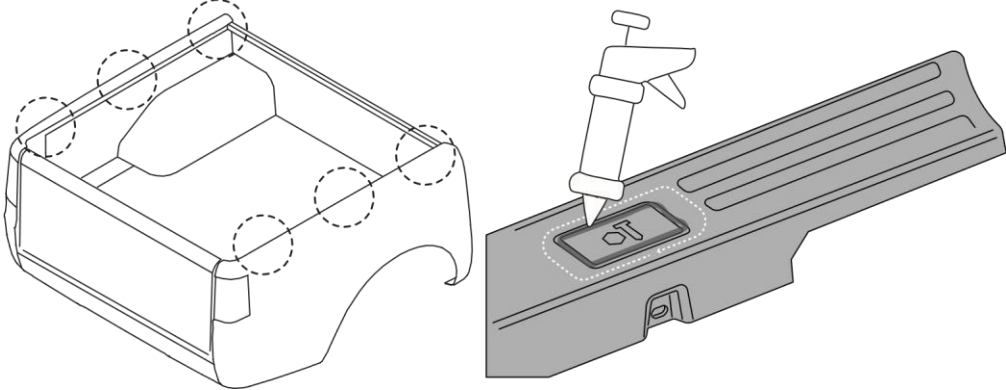
<p>Step 5</p> <ul style="list-style-type: none"> • Locate the holes beneath the rails in the front upper corners of the deck. • With the recessed tab of the foam block facing downward, push the block up under the rail to fill the void. Ensure the recessed tab is hanging down over the sheet metal so that the block does not fall into the cavity. • Repeat for the opposite side. 	 <p>Note: if CMS rail is installed, remove it to aid installation.</p>
<p>Step 6</p> <ul style="list-style-type: none"> • Using non-acetic silicone, seal around the foam blocks filling any holes or voids. • Inspect the front corners of the vehicle deck and fill any holes or voids. • Clean up excess silicone. 	
<p>Step 7 (OPTIONAL- Ford Ranger Only)</p> <ul style="list-style-type: none"> • Locate the 6 access caps on the tops of the rail caps. • Apply a bead of silicone around the perimeter of the cap. • Clean up any excess silicone. 	

FORD RANGER 22+ & VW AMAROK 23+ FITTING INSTRUCTION

READ INSTRUCTIONS CAREFULLY BEFORE COMMENCING THIS ACTIVITY.

READ BEFORE PROCEEDING

1. Recommend installing central locking kit before proceeding, refer 10057994 GRP HL FOR RAN 22+ CNTRL LKNG
2. If installing a tub liner, ensure it is installed before proceeding.

Step 8

- Remove the 8 scrivenets from the rail caps.

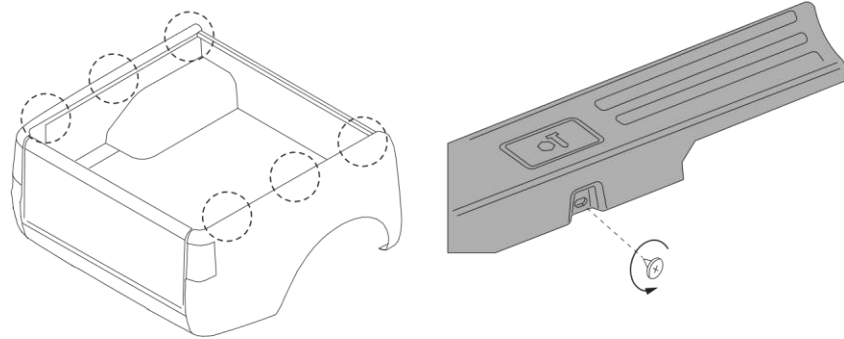

Note: If CMS mount rails are not being installed skip to Step 12.

Step 9

- Ensure the LH & RH side factory mounting brackets are installed in the front corners.
- Use the factory supplied fasteners.
- Install item 3.2 using item 3.10, 3.11 & 3.12.

Torque M8 fasteners to 8Nm
Torque M6 fasteners to 6Nm.

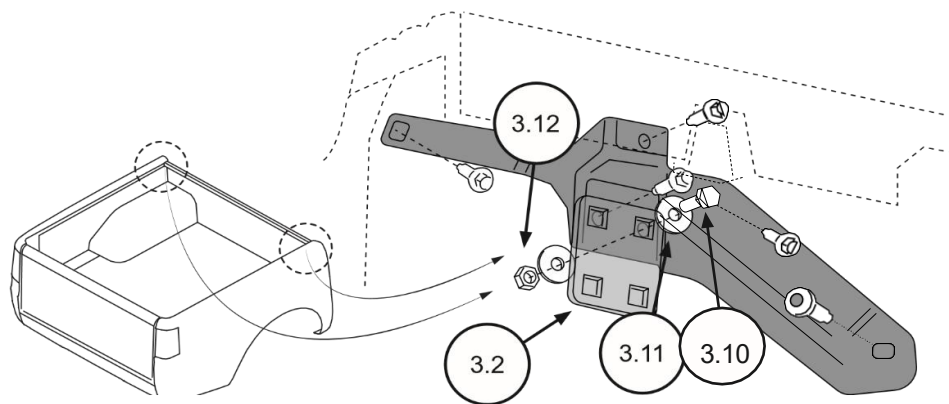

FORD RANGER 22+ & VW AMAROK 23+ FITTING INSTRUCTION

READ INSTRUCTIONS CAREFULLY BEFORE COMMENCING THIS ACTIVITY.

<p>Step 10</p> <ul style="list-style-type: none"> • Install the LH & RH central mounting brackets. • Install item 3.3 & 3.4 using the factory supplied hardware. Position item 3.4 between the plastic rail cap and vehicle tub. • Orientate item 3.4 with the slot toward the front of the vehicle. <p>Torque all fasteners to 6Nm.</p>	
<p>Step 11</p> <ul style="list-style-type: none"> • Do not reinstall the rear factory brackets. • Retain the M8 screws and nuts. • Discard the rear factory brackets, M6 screws & M6 nuts. 	
<p>Step 12</p> <ul style="list-style-type: none"> • Install item 3.5 (LH) and 3.6 (RH) using the push rivet removed in step 8. • Install items 3.9, 3.13 & 3.16. • Ensure that items 3.5 & 3.6 sit inside of the tub sheet metal. <p>Do not fully tighten 3.16 as some adjustment may be required.</p>	

FORD RANGER 22+ & VW AMAROK 23+ FITTING INSTRUCTION

READ INSTRUCTIONS CAREFULLY BEFORE COMMENCING THIS ACTIVITY.

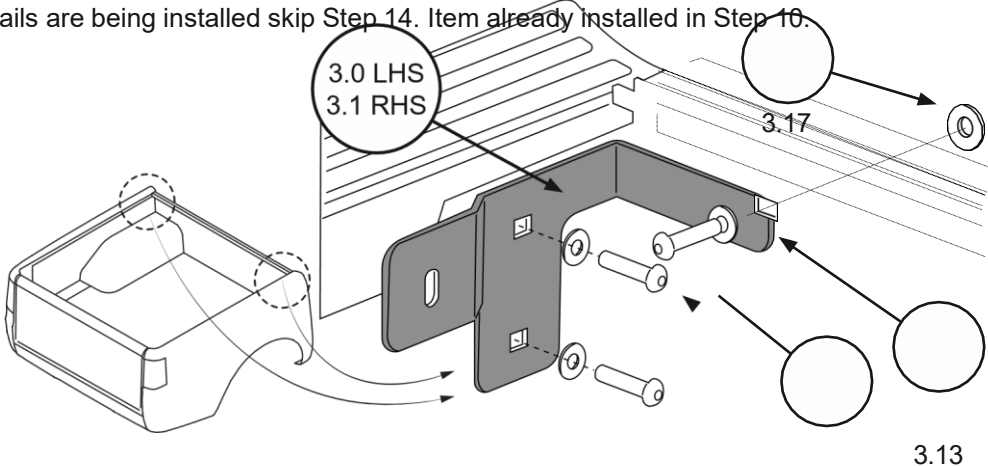
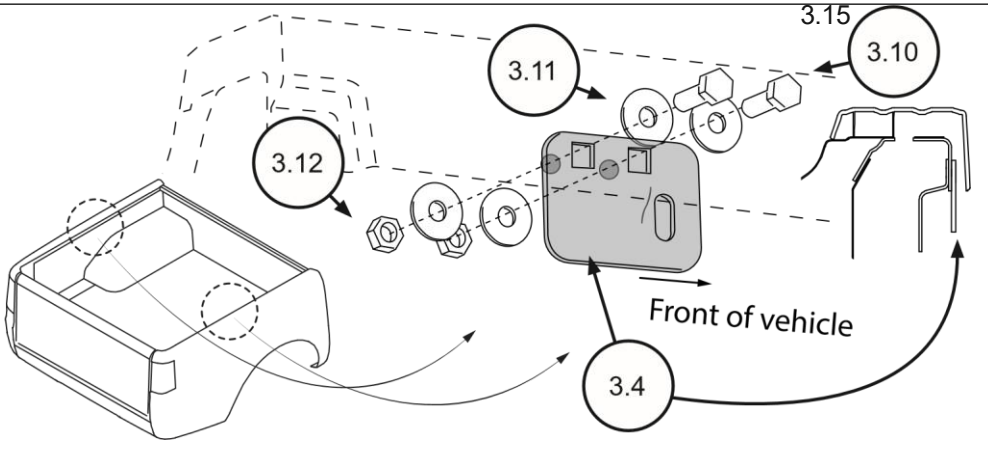
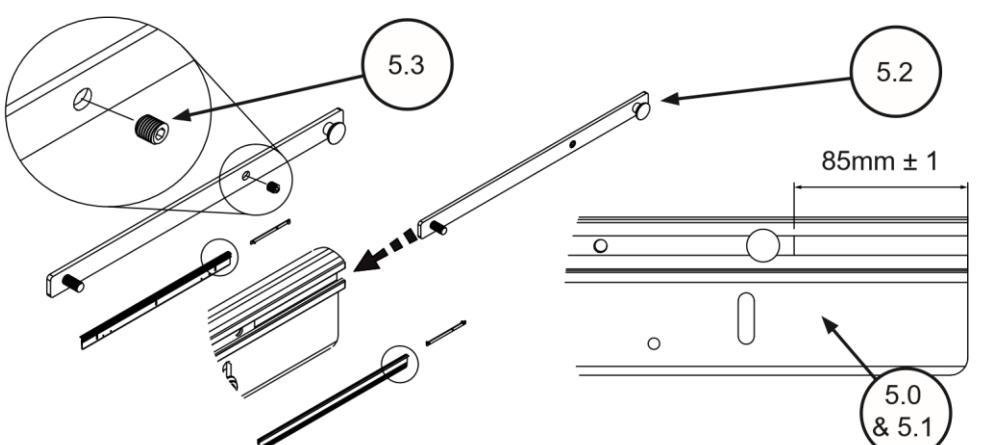
<p style="text-align: center;">Note: If CMS mount rails are being installed skip Step 14. Item already installed in Step 10.</p> <p>Step 13</p> <ul style="list-style-type: none"> Install items 3.0 & 3.1 using items 3.13, 3.15 & 3.17. <p>Torque to 8Nm.</p>	
<p>Step 14</p> <ul style="list-style-type: none"> Install item 3.4 using items 3.10, 3.11 and 3.12. Position item 3.4 between the plastic rail-cap and vehicle tub. <p>Torque items to 6Nm</p> <ul style="list-style-type: none"> Reinstall factory push rivets removed in step 8. 	
<p>Step 15</p> <ul style="list-style-type: none"> Assess sub-assemblies 5.0 & 5.1, ensure item 5.2 is 85mm from the front end of the rail. 	

FORD RANGER 22+ & VW AMAROK 23+ FITTING INSTRUCTION

READ INSTRUCTIONS CAREFULLY BEFORE COMMENCING THIS ACTIVITY.

Step 16

- Loosen the screw item A and slide the item 5.6 & 5.7 to the front.

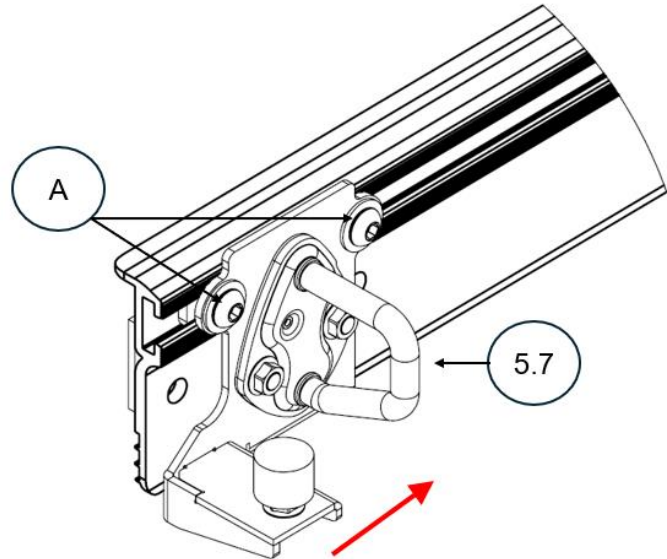

Step 17

- Loosely attach VCRs 5.0 & 5.1 to vehicle using items 3.8, 3.13, 3.14, & 3.15.
- Make sure VCRs are in the correct orientation; item 5.2 located at the front of the vehicle.

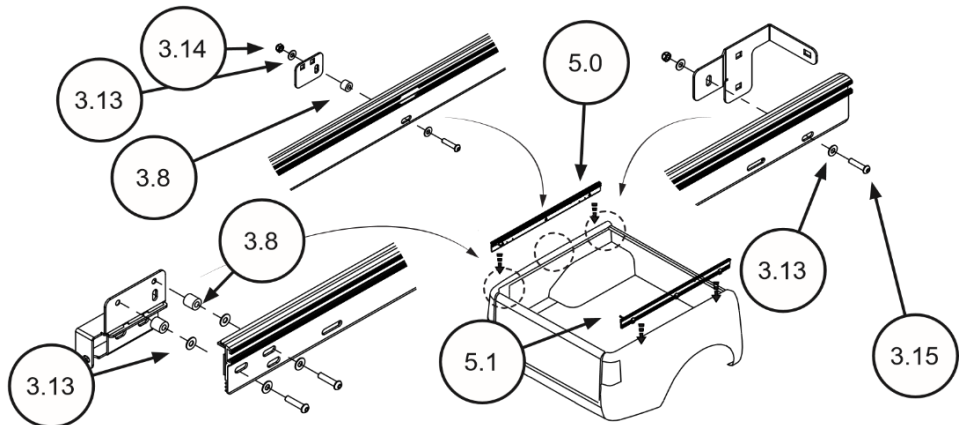

Step 18

- Position item 5.0 & 5.1 55mm from the inside face of the front header board.
- Apply downward pressure to ensure the foam seal is contacting the top of the vehicle rail.

Tighten item 3.15 to **8Nm**.

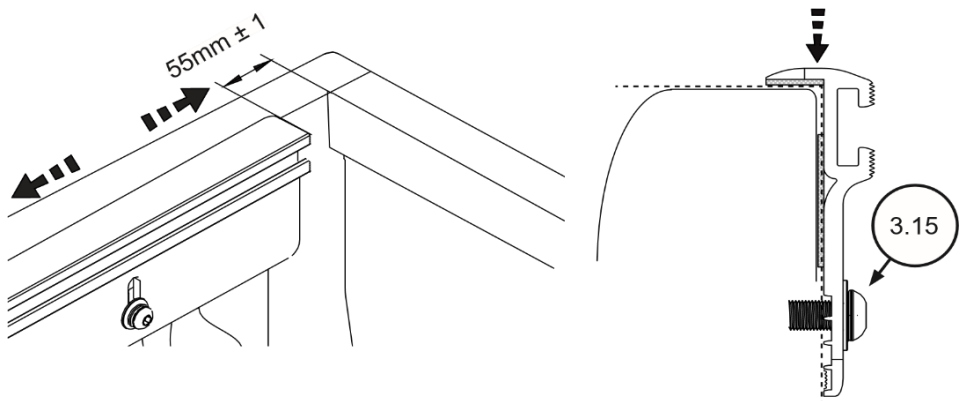

FORD RANGER 22+ & VW AMAROK 23+ FITTING INSTRUCTION

READ INSTRUCTIONS CAREFULLY BEFORE COMMENCING THIS ACTIVITY.

Step 19

- Carefully measure the distance between VCR 5.0 & 5.1 and the front edge of the Sealing Channel.
- Cut D-Seal, item 7.5 into two identical portions to dimension X (measured as shown opposite)

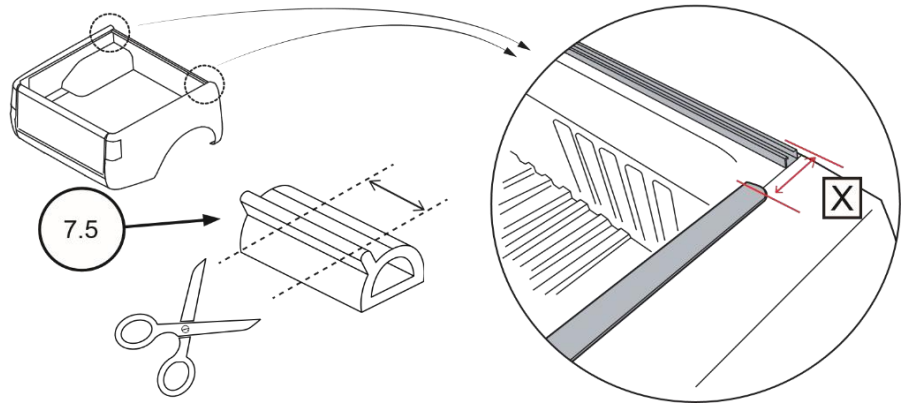

Step 19

- Clean & prime the vehicle rail using remaining primer from Sealing Kit.
- Ensure the cut D-seal is orientated with the rib facing into the vehicle deck.
- Align the edge of the D-seal with the inside face of the vehicle rail.

Push the seal hard up against the Sealing Channel & VCR and ensure there are no gaps between the parts.

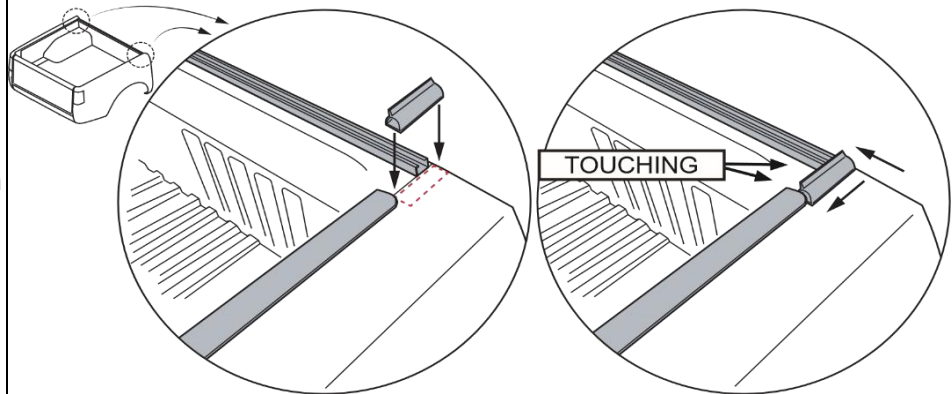

Step 20

- Fill the internal edges between D-seal and drip rail mounting rail with silicone.

Clean excess silicone with a cloth.

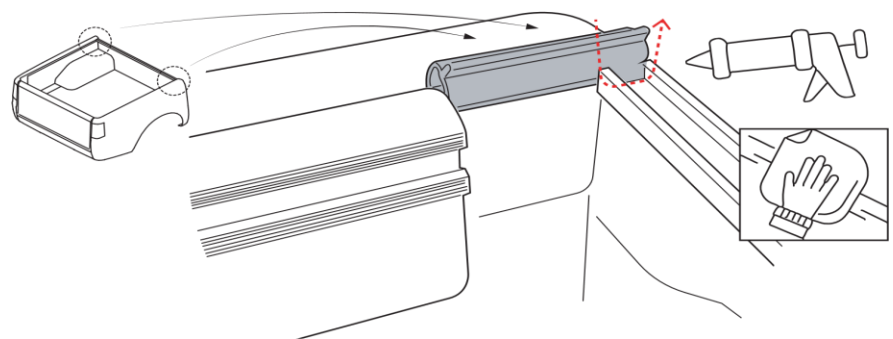

FORD RANGER 22+ & VW AMAROK 23+ FITTING INSTRUCTION

READ INSTRUCTIONS CAREFULLY BEFORE COMMENCING THIS ACTIVITY.

Step 21

- Run a bead of silicone approximately 150mm along edge of VCR and into the join between the D-seal.
- Using a wet finger finish the bead neatly.
- Remove excess silicone using a cloth.

Ford Ranger only:

- Locate the 4 horizontal rib details.
- Fill the small void with silicone.

Clean and remove any excess silicone with a cloth.

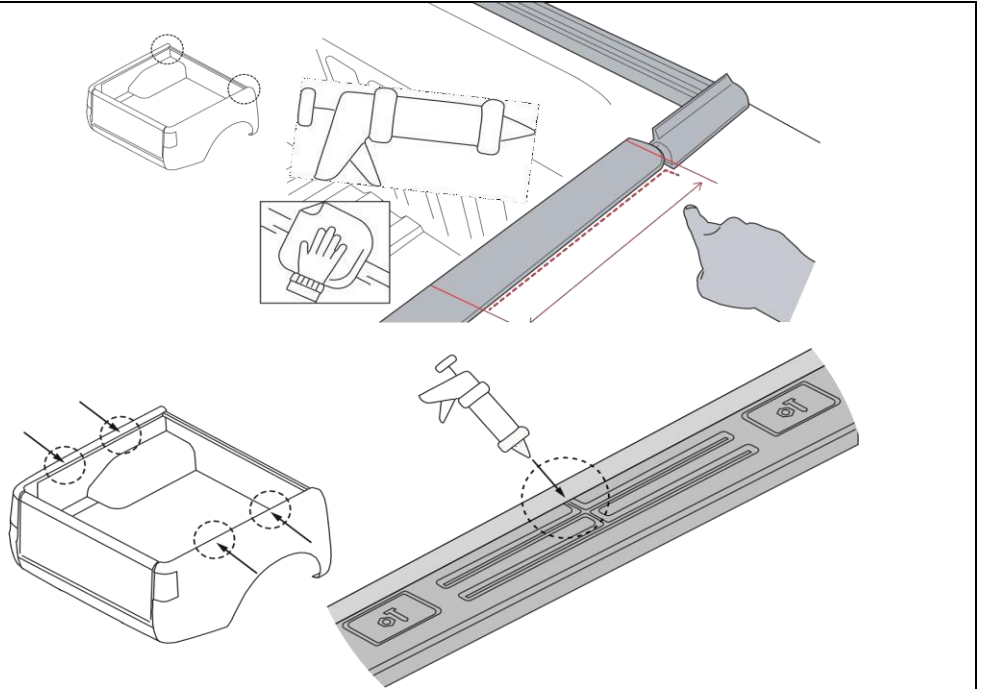

FORD RANGER 22+ & VW AMAROK 23+ FITTING INSTRUCTION

READ INSTRUCTIONS CAREFULLY BEFORE COMMENCING THIS ACTIVITY.

Step 22
FORD RANGER ONLY
This step is only applicable to vehicles supplied with a factory sport bar.

- Clean and prime the vehicle surfaces around the holes left in the plastic side rails.
- Remove the backing from the foam adhesive & cover the front corner holes using Item 2.6.

Remove the backing from the foam adhesive & cover the rear holes using Item 2.7.

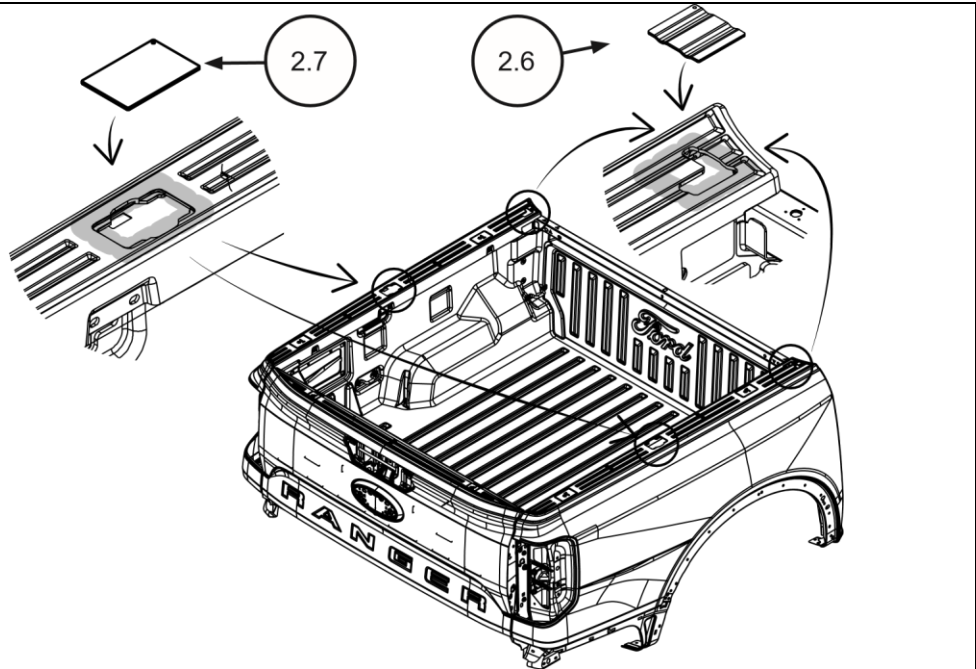

Step 23
VW AMAROK ONLY
This step is only applicable to vehicles supplied with a factory sport bar.

- Clean and prime the vehicle surfaces around the holes left in the plastic side rails.
- Remove the backing from the foam adhesive & cover the front corner holes using Item 2.8.

Remove the backing from the foam adhesive & cover the rear holes using Item 2.9 & 2.10.

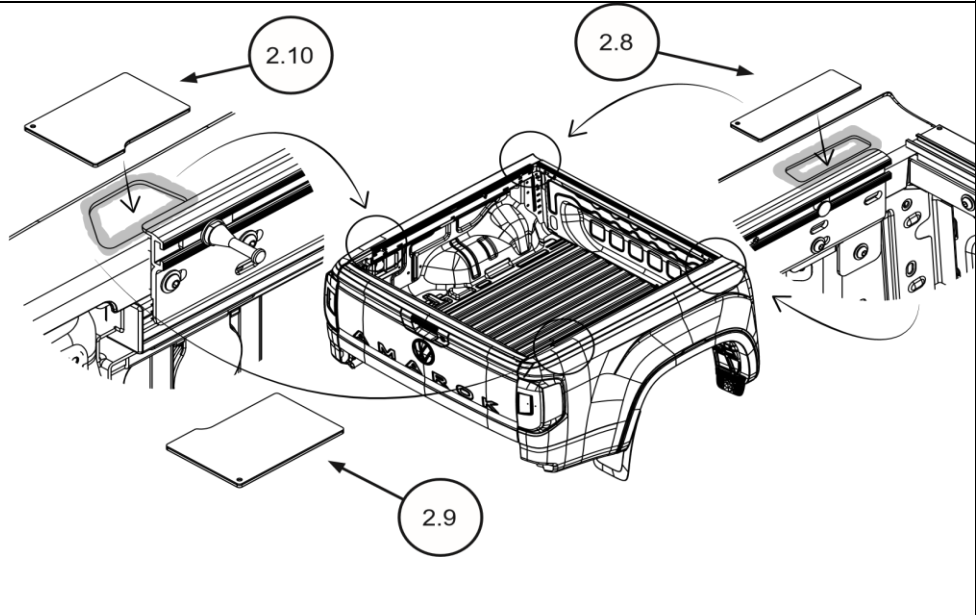

If installing a Sport-Bar, ensure all installation steps are complete before proceeding to next step

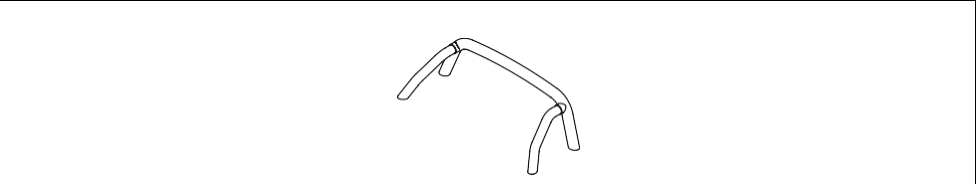

FORD RANGER 22+ & VW AMAROK 23+ FITTING INSTRUCTION

READ INSTRUCTIONS CAREFULLY BEFORE COMMENCING THIS ACTIVITY.

Step 24

- Install the gas struts item 2.0 onto hinges 6.0 & 6.1.

HardLid is supplied with 400N Gas Struts which are suitable for an unloaded lid. We recommend a maximum loading of 25 kgs when opening the lid. If you require your lid to remain open whilst loaded, you will need to purchase a Heavy Load Strut Upgrade kit which is available through your local service centre.

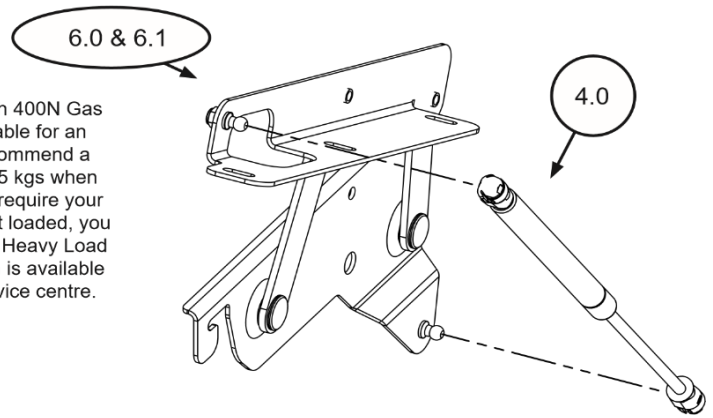

Step 25

- Turn the lid over and attach the LH & RH hinges, using fasteners 7.0 & 7.1

Ensure the inside edge of the hinge is offset from the inside of the frame by 7mm.

Torque item 7.0 to **8Nm**.

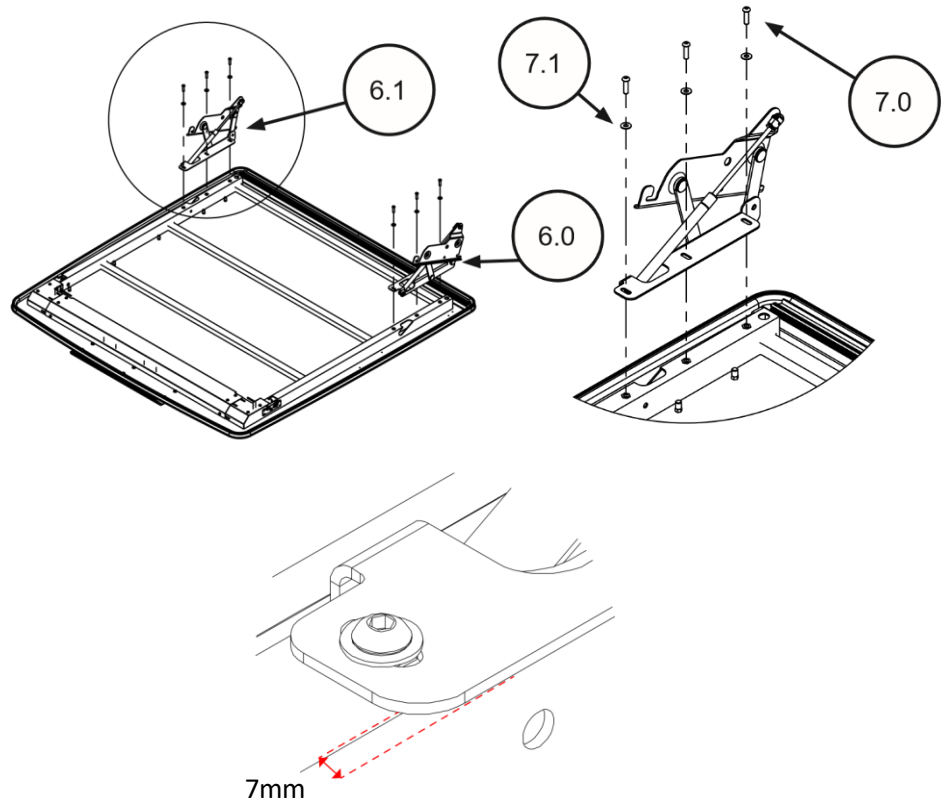

FORD RANGER 22+ & VW AMAROK 23+ FITTING INSTRUCTION

READ INSTRUCTIONS CAREFULLY BEFORE COMMENCING THIS ACTIVITY.

Step 26

- Install the assembled lid onto the vehicle connector rails.
- Locate the hinges as per instruction.

2-person lift required.

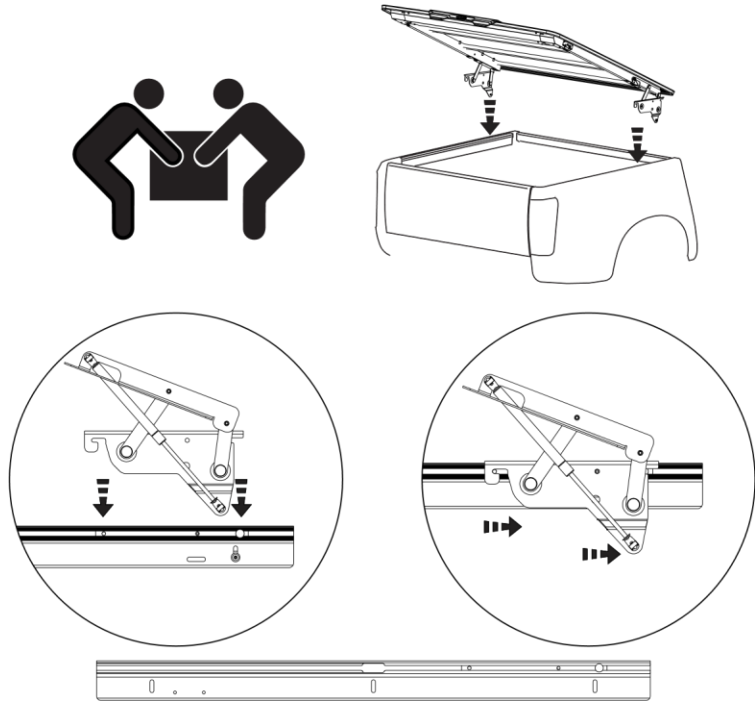

Step 27

If the HardLid is exposed to high vibration situations i.e. extended periods of off-road driving or applying loads on top of lid, it is recommended that the high vibration packers are installed.

- Tilt the bottom of hinge inward and slide the hinge packer (7.3) up and in behind the hinge. Locate it using the 16mm pilot hole.
- Fasten into position using item (7.2, 7.4 & 7.6). Torque item 7.2 & 7.6 to **8Nm**.
- Repeat for opposite side.

If parts are not installed ensure they are stored with the user manual.

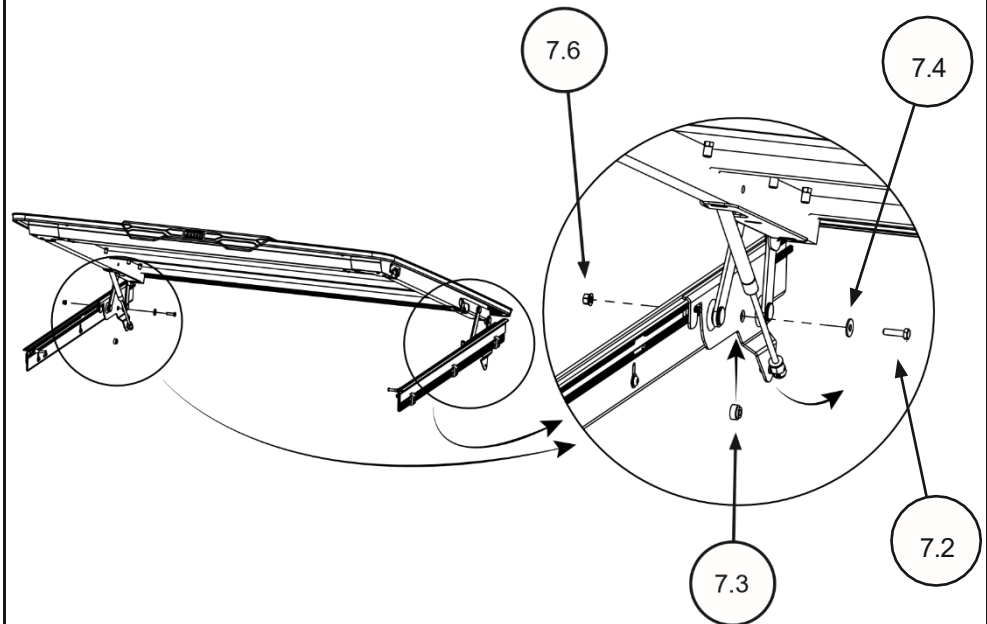

FORD RANGER 22+ & VW AMAROK 23+ FITTING INSTRUCTION

READ INSTRUCTIONS CAREFULLY BEFORE COMMENCING THIS ACTIVITY.

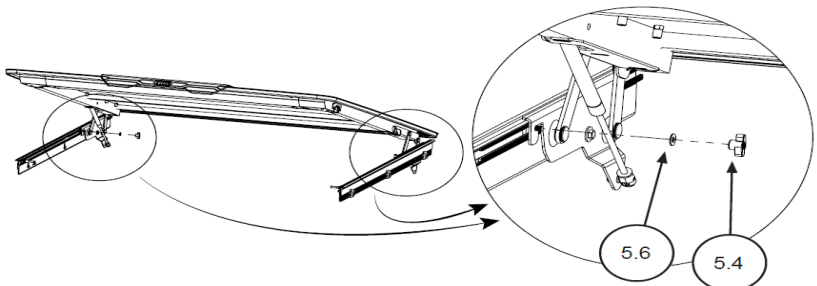
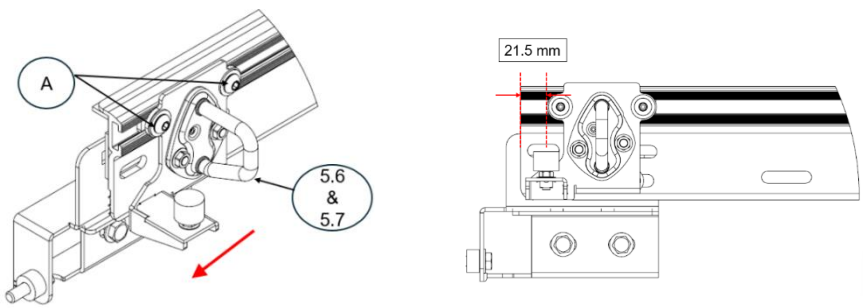
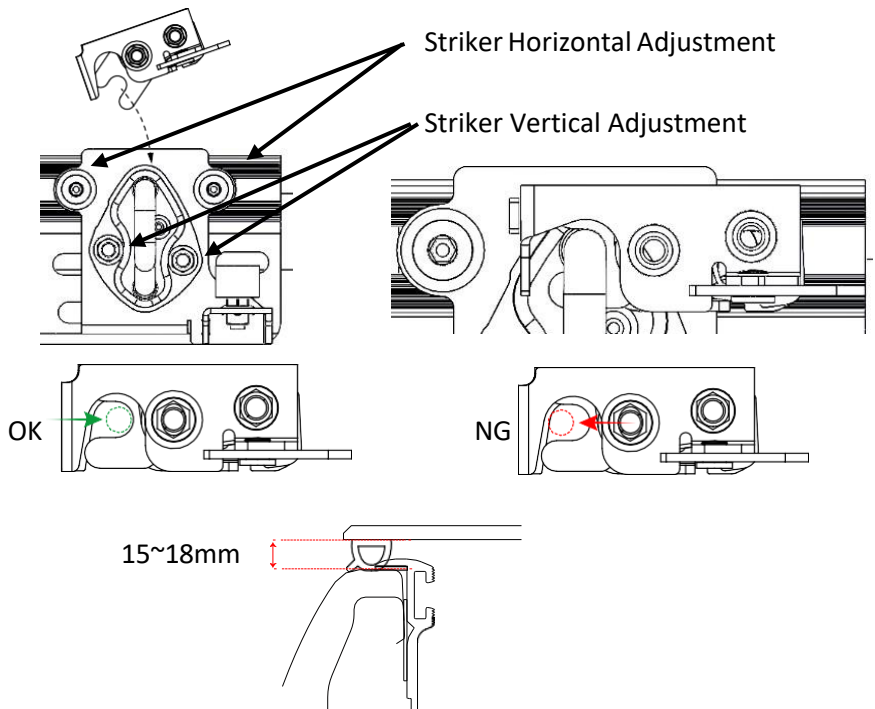
<p>Step 28</p> <ul style="list-style-type: none"> Install washer (5.6) and thumbscrew (5.4). 	
<p>Step 29</p> <ul style="list-style-type: none"> Slide item 5.6 & 5.7 back to the position. <p>21.5 mm from the rear side face of VCRs.</p>	
<p>Step 30</p> <ul style="list-style-type: none"> Open the vehicle tail- gate. Close the lid and align the strikers with the latches. Close the vehicle tailgate and close the lid again. Check to see that the weather seal is evenly contacting the vehicle surfaces around the perimeter of the vehicle tub. <p>Note: ensure the strikers fasteners are not tightened.</p> <ul style="list-style-type: none"> Aim for 15-18mm gap between vehicle surfaces and lid. Once latch position is confirmed, tighten the strikers fasteners to 6NM. 	<p>For best results align the pin with the rear of the latch to avoid interference with the latch body.</p> <div style="text-align: center;">  </div>

FORD RANGER 22+ & VW AMAROK 23+ FITTING INSTRUCTION

READ INSTRUCTIONS CAREFULLY BEFORE COMMENCING THIS ACTIVITY.

Step 31

- Open the vehicle tailgate.
- Close the lid and align the strikers with the latches.
- Close the vehicle tailgate and close the lid again. Check to see that the weather seal is evenly contacting the vehicle surfaces around the perimeter of the vehicle tub.

Aim for 15-18mm gap between vehicle surfaces and lid.

For best results align the pin with the rear of the latch to avoid interference with the latch body.

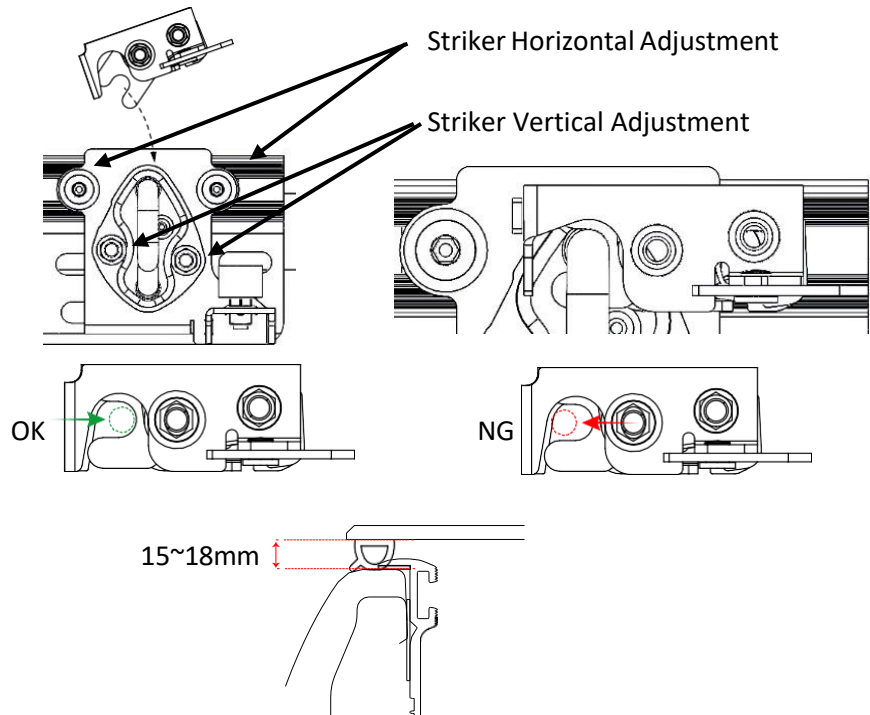

Step 32

- Press rubber drip rail into drip rail channel.

Ensure drip rail is securely locked into channel along full length.

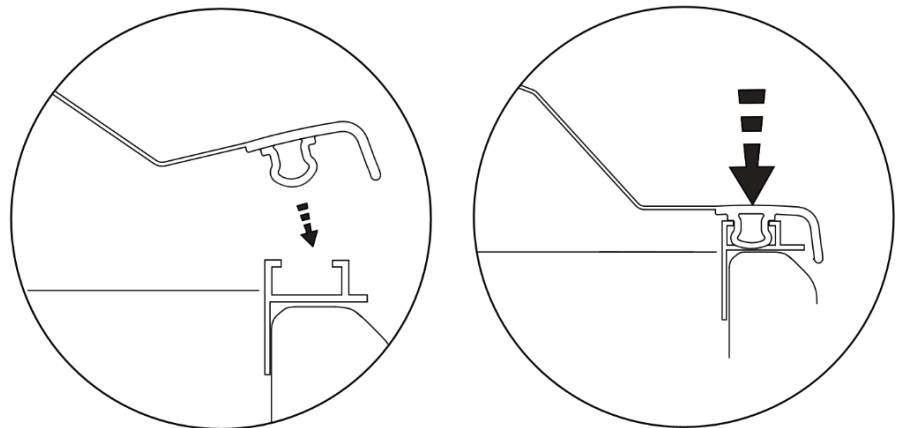

FORD RANGER 22+ & VW AMAROK 23+ FITTING INSTRUCTION

READ INSTRUCTIONS CAREFULLY BEFORE COMMENCING THIS ACTIVITY.

Adjustment 1

- Check if the Hinges collide with vehicle connector rails.
 - Adjust the hinge locations relative to the lid by loosening screws.
- Re-torque to **8Nm** once complete.

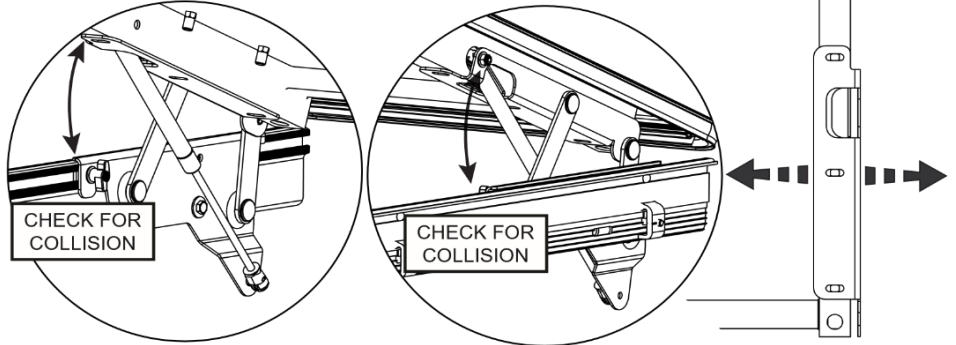

Adjustment 2

- Check the alignment between lid and vehicle.
- If the lid is twisted the hinges can be shifted individually, forwards or backwards to fine tune the position of the lid.
- If the lid is sitting too far forward or too far rearward the hinges can be moved together.
- Loosen hinge fastening hardware.
- Wind the grub screw outward so that it sits flush with the hinge surface. This will allow you to adjust all components simultaneously.
- Shift the hinges in small increments and re-check offsets until satisfied.

Once satisfied with position, retighten all fastening hardware.

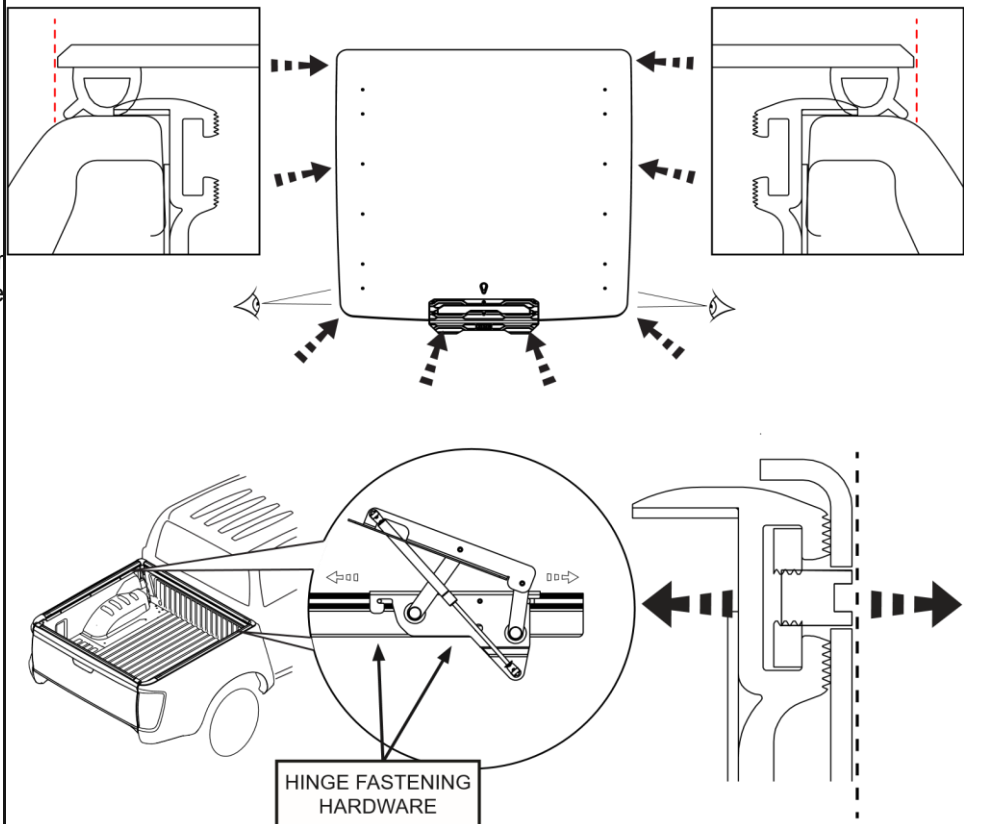

FORD RANGER 22+ & VW AMAROK 23+ FITTING INSTRUCTION

READ INSTRUCTIONS CAREFULLY BEFORE COMMENCING THIS ACTIVITY.

Adjustment 3

- If latching sensitivity requires adjustment, cable tension can be increased or decreased.
- Loosen the locknut and rotate the barrel adjuster as follows:-
 - Clockwise to decrease tension
 - Anti-clockwise to increase tension
- Ensure the locknut is securely fastened
- If there is insufficient adjustment, refer next step.

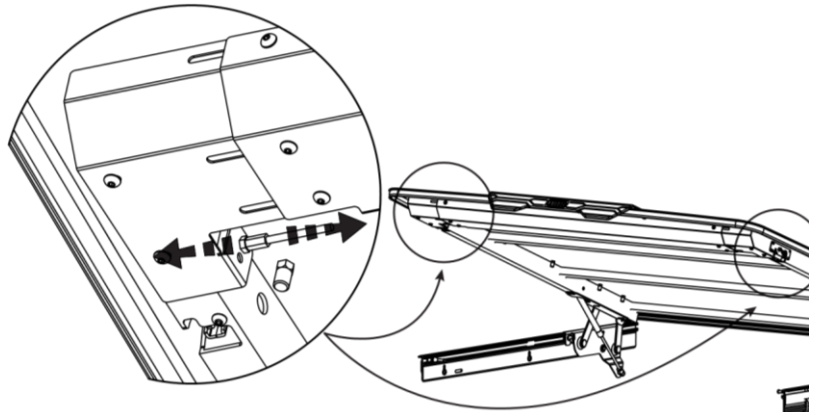

Adjustment 4

- Remove the service cover
- Loosen the locknut and rotate the barrel adjuster as follows:-
 - Clockwise to decrease tension
 - Anti-clockwise to increase tension
- Adjust the cable tension so both latches operate simultaneously
- Ensure the locknut is securely fastened
- Reinstall the service cover

