



**4X4 ACCESSORIES**

# **FORD RANGER & MAZDA BT50 11+ HARDLID FITTING INSTRUCTIONS**

**Suits PXI, II, III, BT50 & Raptor**

**Instruction # 37800605**

**Fitting Kit Part # 10058596**

# FORD RANGER & MAZDA BT50 11+ FITTING INSTRUCTION

## ORDER OF OPERATIONS:

1. Install central locking patch harness first. Note that PXI, II, III & BT50 use a different patch harness to Raptor & Adblue models.

1.1 For PXI, II, III & BT50 use part 10055663.

1.2 For Raptor & Adblue use 10055833.

2. If a styling bar with a Central High Mount Stop Light (CHMSL) is going to be installed ensure that the patch harness is installed.

2.1 For ARB after market bar use kit 10058720

2.2 For Ford OEM bar (FOAMAB3J2155174BA) use kit 10058722

2.3 For Ford OEM FX4 bar use kit 10058724

3. Install the vehicle tub liner. Trimming of tub liner may be required. See below for trimming instruction. ARB HardLid is compatible with:

3.1 ARB Sport Guard

3.2 ARB Under Rail Bedliner

3.3 Ford OEM Bed Liner

4. Install styling bar onto HardLid

5. Install the HardLid Fitting Kit

6. Install the HardLid onto the vehicle.

7. Install any additional accessories such as roof racks.

- HardLid is supplied with 400N Gas Struts which are suitable for an unloaded lid. Recommended maximum loading of 25 kgs when opening the lid. If you require your lid to remain open whilst loaded, you will need to purchase a Heavy Load Strut Upgrade Kit which is available through your local dealer. Please use one of the following part numbers as a reference when contacting your dealer:

| ARB NZ Part # | ARB AU Part # | Gas Strut N |  |
|---------------|---------------|-------------|--|
| 10056207      | 176202        | 450N        |  |
| 10056209      | 176201        | 500N        |  |

- Read through the fitting instructions before installation of accessory.
- Check that the contents of the Fitting Kit are complete and undamaged.
- If any contents of the Fitting Kit are found incomplete or damaged they must be replaced using the specified accessory components.
- Always install the accessory following the fitting instructions. Failure to do so may cause damage to the vehicle or the accessory and void the warranty.
- Ensure all recyclable discarded vehicle/accessory components and packaging are disposed following local recycling regulations.
- Safely store and protect any removed vehicle components.
- Ensure all bare metal surfaces are protected using Automotive Bare Metal Primer and touch-up paint.
- Remove all metal swarf and dust from all vehicle surfaces.
- Ensure all fasteners are torqued to the specifications as per instruction.
- Apply any adhesives to the vehicle only when the surface temperature is between 20°C to 40°C.
- **Bedliner:** Recommended rust preventative solution be applied to vehicle surfaces before installation.

## General Vehicle and Accessory Warranty Notes and Cautions



- For correct installation and proper operation of the vehicle and accessory we recommend this accessory is fitted by a qualified Technician.
- During the accessory fitment ensure all automotive safety practices and regulations are followed.
- Do not modify the vehicle in any way other than specified in these Accessory Fitting Instructions as this may void the warranty.



## Safety Notes

- Check that all work practices comply with safety standards.
- It is advisable to seek assistance from another person when lifting heavy components.
- While using power tools ensure safe procedures are followed.
- Appropriate clothing & PPE must be worn.

# FORD RANGER & MAZDA BT50 11+ FITTING INSTRUCTION

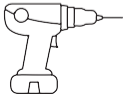
**READ INSTRUCTIONS CAREFULLY BEFORE COMMENCING THIS ACTIVITY.**

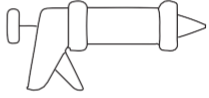
| No.                   | Description                 | Image   |
|-----------------------|-----------------------------|---|
| <b>Tools Required</b> |                             |   |
| 1                     | METRIC HEX KEY SET          |  |
| 3                     | METRIC SPANNER SET          |  |
| 5                     | CLEANING RAGS               |  |
| 7                     | POWER DRILL & 5MM DRILL BIT |  |

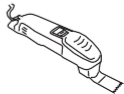

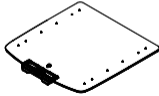

| No.                   | Description                | Image   |
|-----------------------|----------------------------|---|
| <b>Tools Required</b> |                            |   |
| 2                     | METRIC RULER               |  |
| 4                     | CLEAR NON-ACETIC SILI-CONE |  |
| 6                     | TROQUE WRENCH              |  |
| 8                     | OSCILLATING SAW            |  |

| No. | Service part No. | QTY | Image |
|-----|------------------|-----|-------|
|-----|------------------|-----|-------|

## 1. HardLid

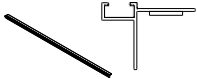
|     |         |   |   |
|-----|---------|---|---|
| 1.0 | HARDLID | 1 |  |
|-----|---------|---|---|

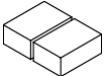
## 2. Sealing & Protection Kit







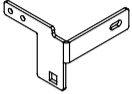
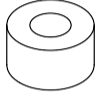
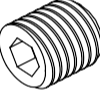
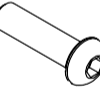
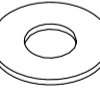
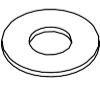
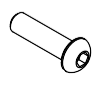

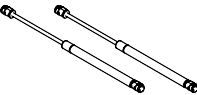
|     |  |   |   |
|-----|--|---|---|
| 2.0 | 10058595<br>SEALNG CHANNEL             | 1 |  |
| 2.1 | 10051996<br>3M 94 PRIMER               | 2 |  |
| 2.2 | 10051664<br>ISOPROPYL ALCOHOL<br>WIPES | 2 |  |
| 2.3 | 10055099<br>TUB SEALING BLOCKS         | 1 |  |
| 2.4 | HL08PK<br>VINYL PROTECTION             | 1 |  |

# FORD RANGER & MAZDA BT50 11+ FITTING INSTRUCTION

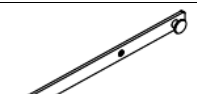
**READ INSTRUCTIONS CAREFULLY BEFORE COMMENCING THIS ACTIVITY.**



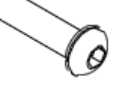

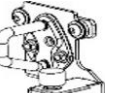
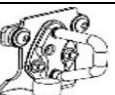





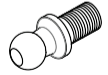

| No.  | Service part No.                         | QTY | Image   |
|--|--|-----|---|
| <b>3. Mounting Brackets &amp; Hardware</b> |  |     |   |
| 3.0  | 10058593<br>MOUNT BRACKET<br>FRONT LHS   | 1   |    |
| 3.1  | 10058594<br>MOUNT BRACKET<br>FRONT RHS   | 1   |    |
| 3.2  | 10057890<br>SPACER M8X10X18MM            | 2   |    |
| 3.3  | 10055553<br>M8X10MM GRUB<br>SCREW        | 4   |    |
| 3.4  | 10053299<br>BUTTON HEAD<br>SCREW M8X30MM | 2   |    |
| 3.5  | 10003717<br>WASHER FLAT<br>M8X19X1.2MM   | 2   |   |
| 3.6  | 10053451<br>WASHER FLAT<br>M6X19X1.6MM   | 2   |  |
| 3.7  | 10055841<br>BUTTON HEAD<br>SCREW M6X20MM | 2   |  |

| <b>4. Gas Struts</b>  |                            |   |   |
|---|----------------------------|---|---|
| 4.0   | 10058202<br>GAS STRUT PAIR | 1 |  |
| <p>Sportlid is supplied with 400N Gas Struts which are suitable for an unloaded lid. We recommend a maximum loading of 25 kgs when opening the lid. If you require your lid to remain open whilst loaded, you will need to purchase a <b>Heavy Load Strut Upgrade Kit</b> which is available through your local dealer- refer to user manual for part number information.</p> |                            |   |   |

| No.  | Service part No.                              | QTY | Image   |
|--|---|-----|---|
| <b>5. Mounting Rails</b>   |   |     |   |
| <p>Note: Items 5.2 - 5.9 are pre-assembled as part of 5.0 &amp; 5.1<br/>Ensure that sub assemblies contain all parts before commencing installation.</p> |   |     |   |
| 5.0  | 10057823<br>HARDLID LEFT VCR<br>ASSEMBLY      | 1   |    |
| 5.1  | 10057824<br>HARDLID RIGHT VCR<br>ASSEMBLY     | 1   |    |
| 5.2  | 10055552<br>HINGE MOUNT                       | 2   |    |
| 5.3  | 10055553<br>M8X10MM GRUB<br>SCREW             | 2   |    |
| 5.4  | 10000100<br>KNOB FEMALE<br>WING M8            | 2   |  |
| 5.5  | 10003717<br>BL/ WASHER FLAT<br>M8X19X1.2MM SS | 8   |  |
| 5.6  | 10053299<br>M8X30MM B/HEAD                    | 6   |  |
| 5.7  | 10000043<br>C-CLAMP                           | 6   |  |
| 5.8  | 10059215<br>STRIKER ASSY RH<br>(PRE-ASS'D)    | 1   |  |
| 5.9  | 10059214<br>STRIKER ASSY LH<br>(PRE-ASS'D)    | 1   |  |

# FORD RANGER & MAZDA BT50 11+ FITTING INSTRUCTION

**READ INSTRUCTIONS CAREFULLY BEFORE COMMENCING THIS ACTIVITY.**

| No.  | Service part No.                       | QTY | Image   |
|--|--|-----|---|
| <b>6. Hinges</b>   |  |     |   |
| Note: Items 6.2 - 6.4 are pre-assembled as part of 6.0 & 6.1<br>Ensure that sub assemblies contain all parts before commencing installation. |  |     |   |
| 6.0  | 10057826<br>LEFT HINGE ASSEM           | 1   |    |
| 6.1  | 10057827<br>RIGHT HINGE ASSEM          | 1   |    |
| 6.2  | 10056199<br>NUT M8 NYLOC               | 4   |    |
| 6.3  | 10056204<br>BALL STUD                  | 4   |    |
| 6.4  | 10003717<br>WASHER FLAT<br>M8X19X1.2MM | 4   |    |
| <b>7. General Hardware</b>   |  |     |   |
| 7.0  | 10053299<br>M8X30MM B/HEAD             | 6   |   |
| 7.1  | 10003717<br>WASHER M8X19X1.2MM         | 6   |  |
| 7.2  | 10056261<br>M8X30MM SETSCREW           | 2   |  |
| 7.3  | 10055927<br>STEP SPACER                | 2   |  |
| 7.4  | 10055714<br>WASHER M8X24X2MM           | 2   |  |
| 7.5  | 10000091<br>SEAL                       | 0.2 |  |
| 7.6  | 10055835<br>NUT HEX FLANGE M8          | 2   |  |
| 7.7  | 10053982<br>BLACK RIVET                | 8   |  |
| <b>8. Miscellaneous</b>  |  |     |   |
| 8.0  | 10055862<br>OWNERS MANUAL              | 1   |  |

# FORD RANGER & MAZDA BT50 11+ FITTING INSTRUCTION

**READ INSTRUCTIONS CAREFULLY BEFORE COMMENCING THIS ACTIVITY.**

## ARB Sportguard Preperation

It is recomended that the Sportguard be removed from the vehicle before commencing the modifications.

- Locate the Sportguard front panel.
- Trim approximately 15mm off the front header section.

Trim Process is complete.

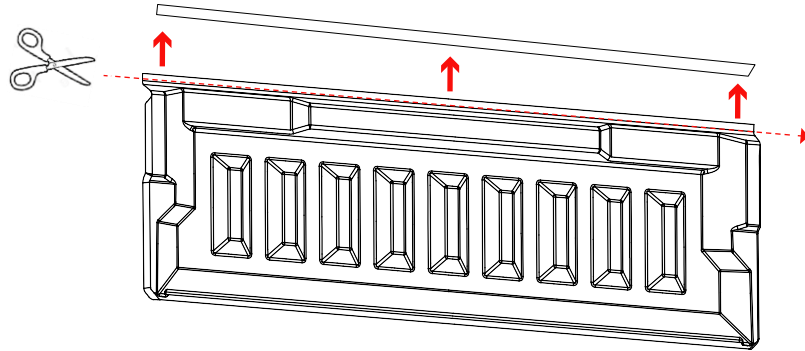

## ARB Under Rail Bedliner Preperation

It is recomended that the Sportguard be removed from the vehicle before commencing the modifications.

- Measure down 35mm from point shown. Trim out LH & RH side corners as per instruction.
- Remove 10mm from top of front header as per illustration.

Trim Process is complete.

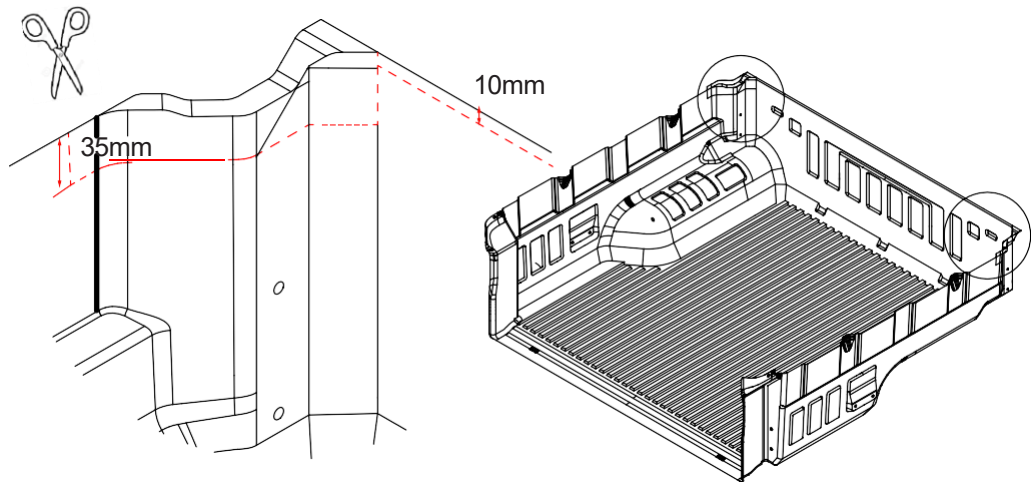

# FORD RANGER & MAZDA BT50 11+ FITTING INSTRUCTION

READ INSTRUCTIONS CAREFULLY BEFORE COMMENCING THIS ACTIVITY.

## Step 1

- Thoroughly clean the top, rear and underside of the front rail using item 2.2
- Thoroughly clean the upper front corners of the deck using item 2.2.

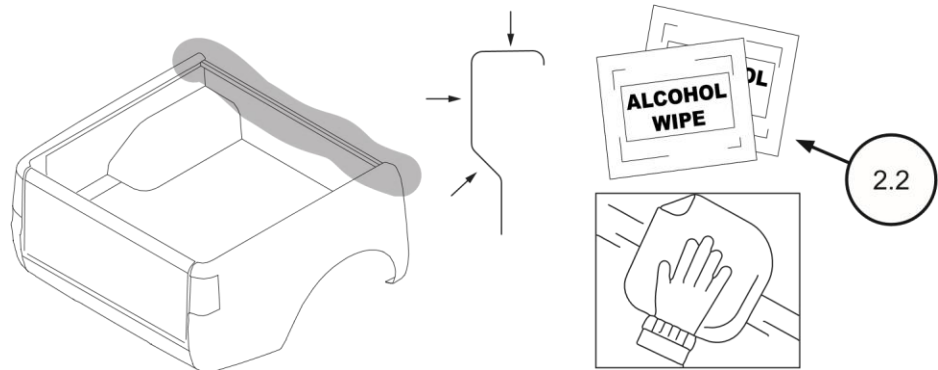

## Step 2

- Apply surface primer, item 2.1 to the entire length of the top surface of the front rail.

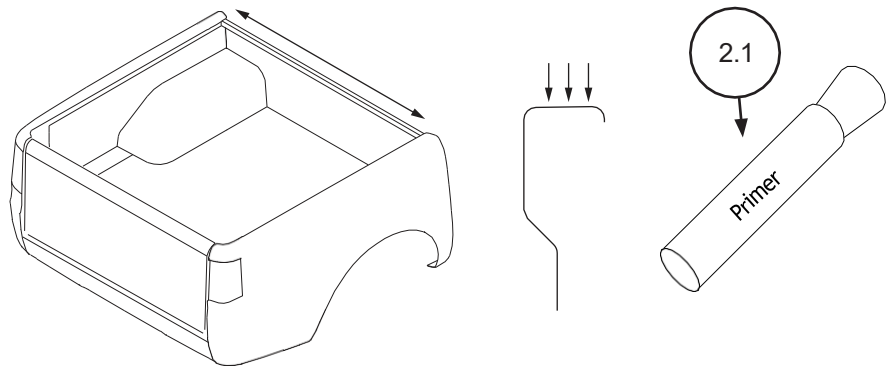

## Step 3

- Remove the backing tape from item 2.0 and attach to front header board.

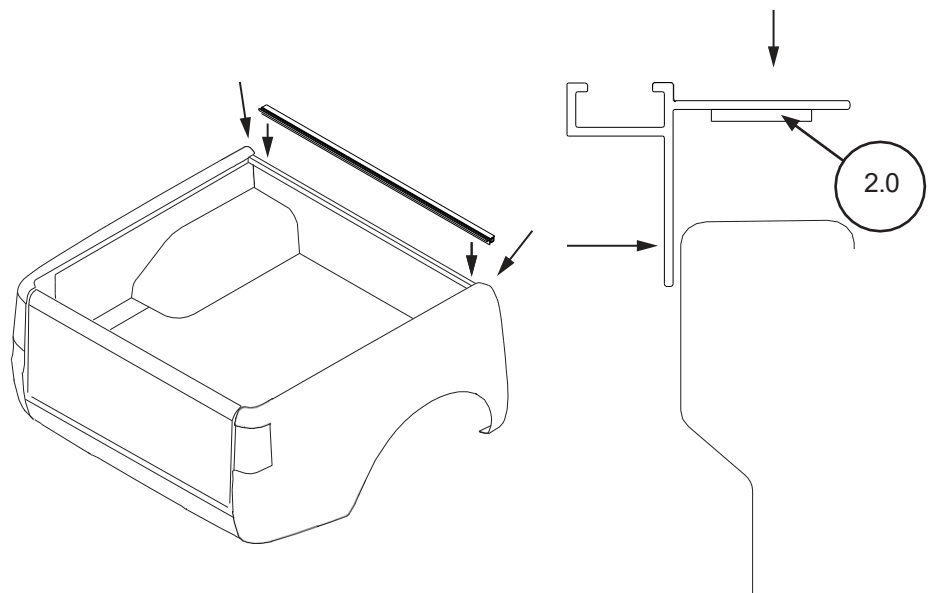

# FORD RANGER & MAZDA BT50 11+ FITTING INSTRUCTION

READ INSTRUCTIONS CAREFULLY BEFORE COMMENCING THIS ACTIVITY.

## Step 4

Note: If installing central locking or CHMSL patch harness ensure this is done before completing step 5.

- Locate the holes beneath the rails, in the front corners of the deck.
- Press the foam sealing blocks into the voids.
- Using non-acetic silicone, seal around the foam blocks filling any holes or voids.

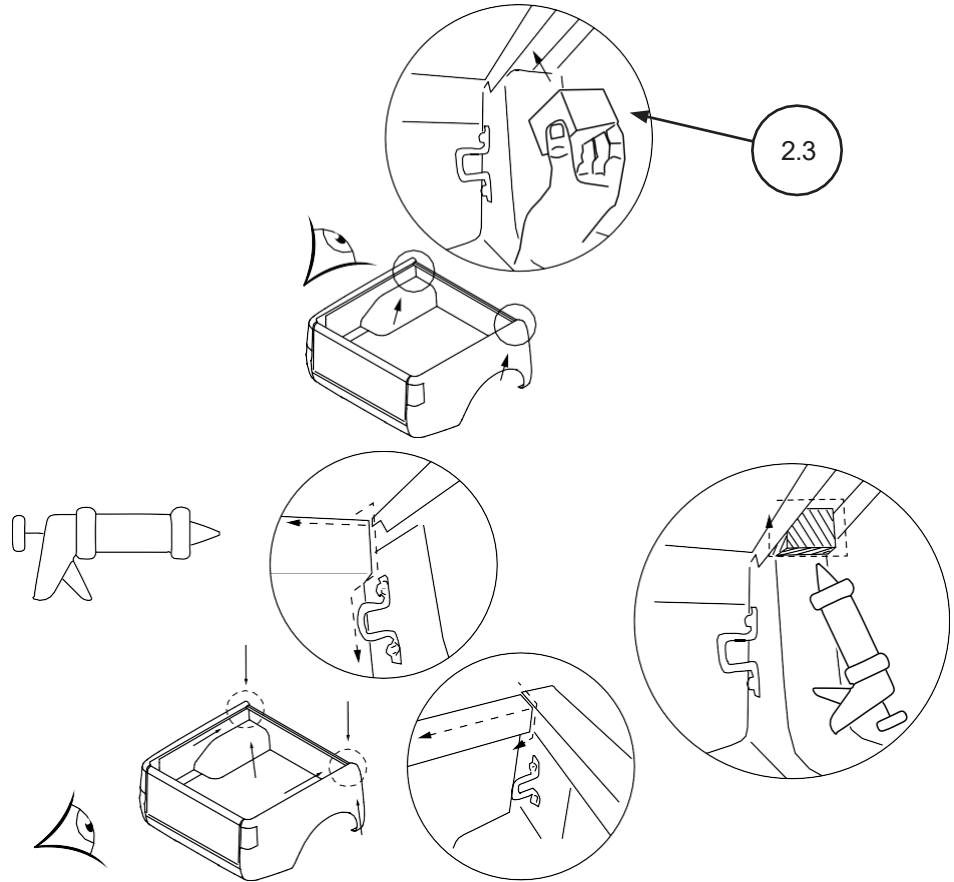

## Step 5

- Install Item 2.4 HL08PK as per included instruction.



Note: image is reference only. Appearance may vary.

# FORD RANGER & MAZDA BT50 11+ FITTING INSTRUCTION

**READ INSTRUCTIONS CAREFULLY BEFORE COMMENCING THIS ACTIVITY.**

## Step 6

- Assess sub assemblies 5.0 & 5.1, ensure item 5.2 is 98mm from the front end of the rail.

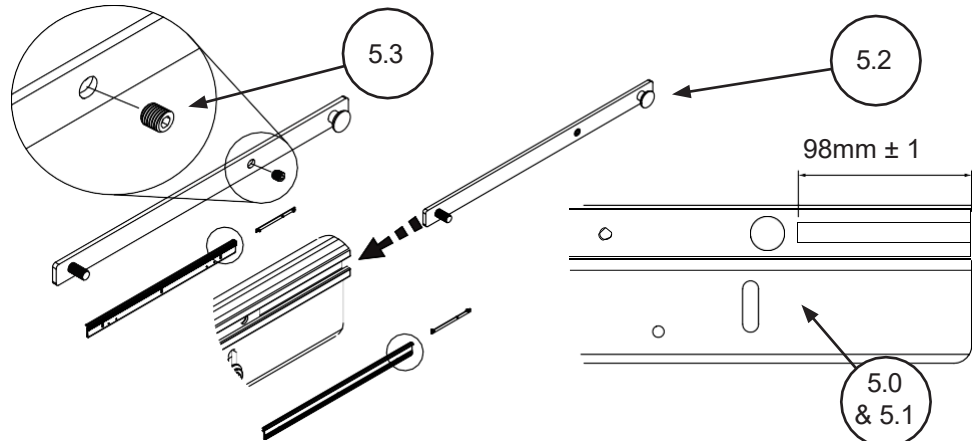

## Step 7

- Loosely attach VCRs 5.0 & 5.1 to vehicle using items 3.0 - 3.7 & 5.5, 5.6 & 5.7.
- Make sure VCRs are in the correct orientation, item 5.2 located at the front of the vehicle.

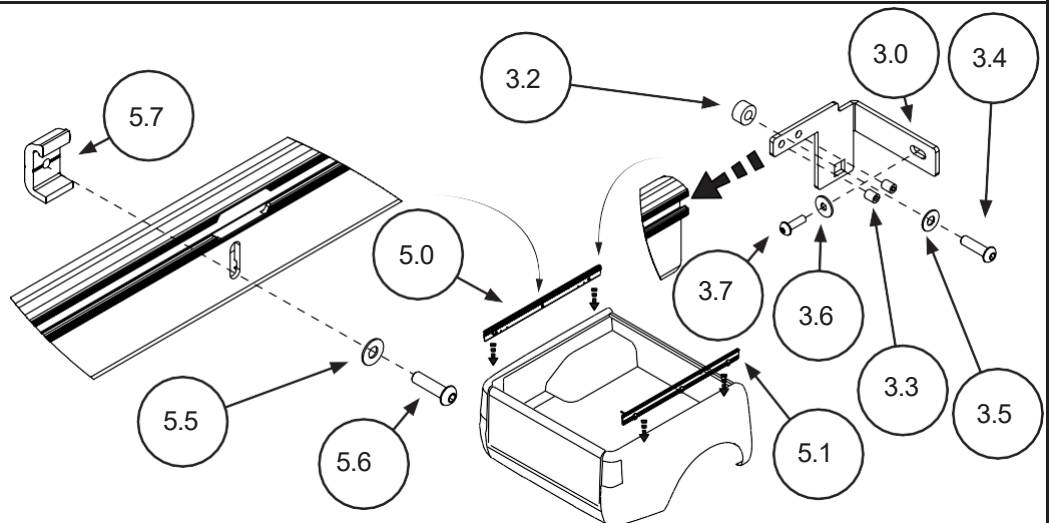

## Step 8

- Position item 5.0 & 5.1 32mm from the inside face of the drip rail channel.
- Apply downward pressure to ensure the foam seal is contacting the top of the vehicle rail.
- Tighten item 3.3, 3.4 & 3.7 to **8Nm**.

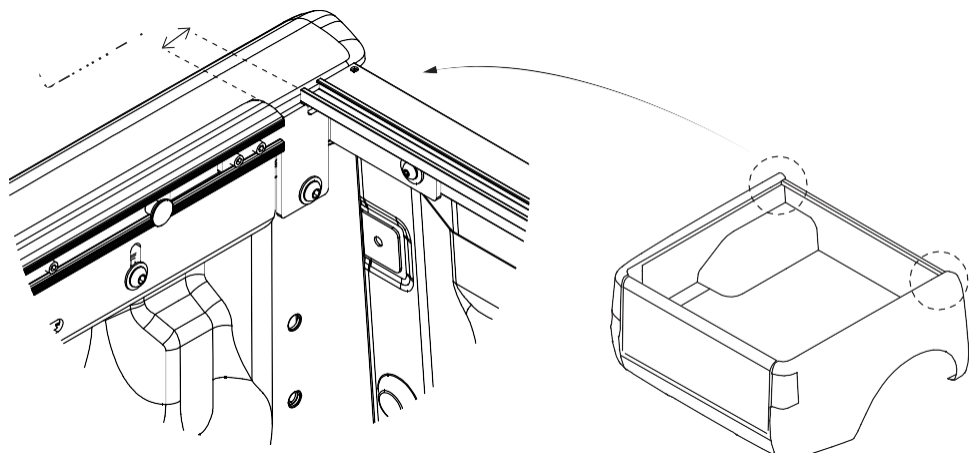

# FORD RANGER & MAZDA BT50 11+ FITTING INSTRUCTION

READ INSTRUCTIONS CAREFULLY BEFORE COMMENCING THIS ACTIVITY.

## Step 9

- Ensure VCRs (5.0 & 5.1) are sitting perpendicular to the top of the vehicle rails.
- Locate C-clamps (5.9) in position 2. Apply downward pressure to the VCR and tighten item (5.10) to **8Nm**.
- Ensure foam is contacting vehicle surface along entire length of rail.

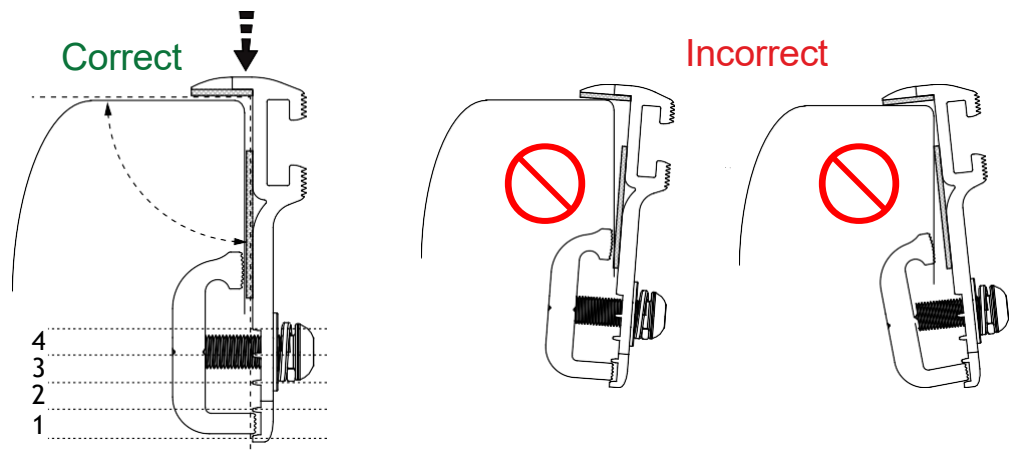

## Step 10

- Carefully measure the distance between VCR 5.0 & 5.1 and the front edge of the Sealing Channel.
- Cut D-Seal, item 7.5 into two identical portions according to dimension X.

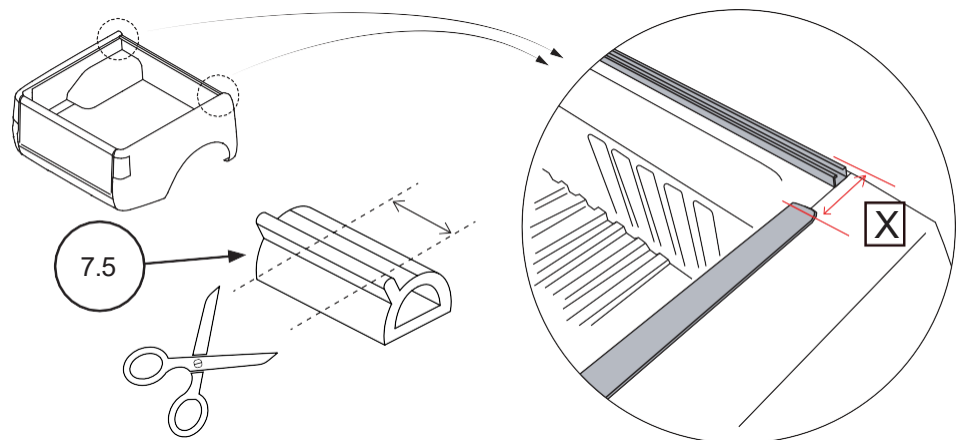

## Step 11

- Clean & prime the vehicle rail using remaining primer from Sealing Kit.
- Ensure the D-Seal, item 7.5 is orientated with the rib facing into the vehicle deck.
- Align the edge of the D-seal, item 7.5 with the inside face of the vehicle rail.
- Push the seal hard up against the Sealing Channel & VCR and ensure there are no gaps between the parts.

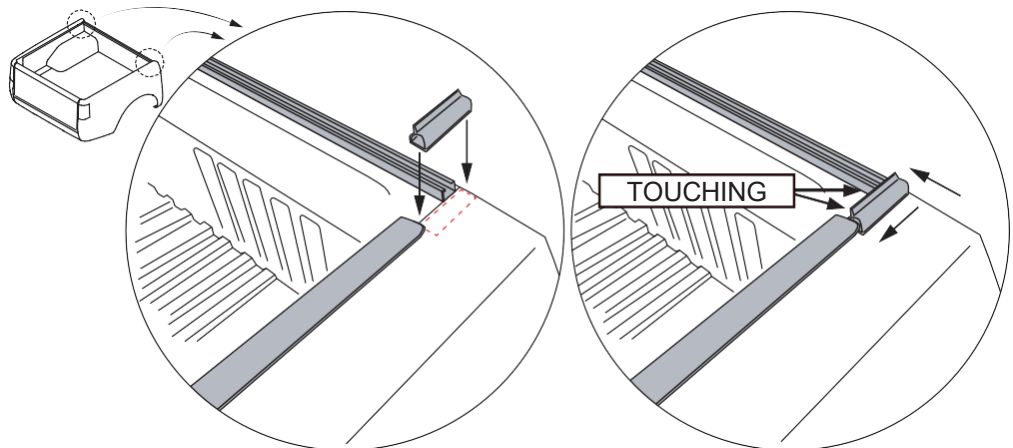

# FORD RANGER & MAZDA BT50 11+ FITTING INSTRUCTION

**READ INSTRUCTIONS CAREFULLY BEFORE COMMENCING THIS ACTIVITY.**

## Step 12

- Fill internal edges between D-seal and drip rail mounting rail with silicone.
- Clean excess silicone with a cloth.

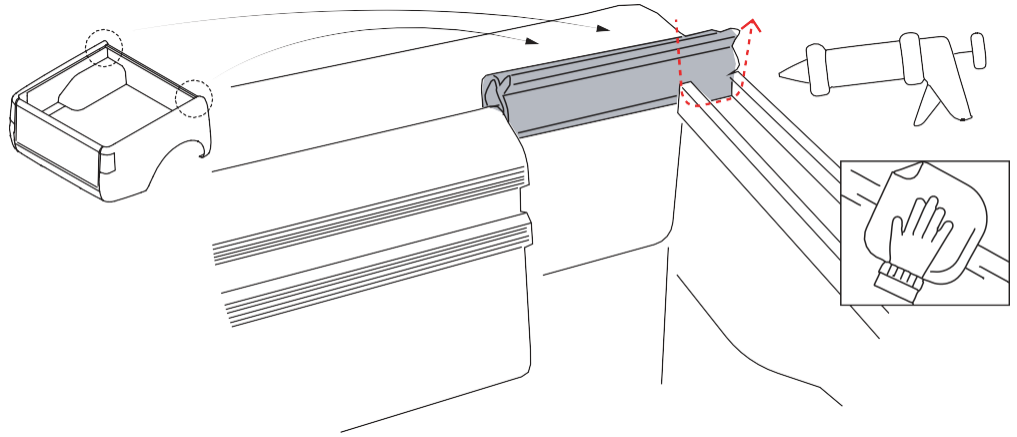

## Step 13

- Run a bead of silicone approximately 150mm along edge of VCR and into the joint between the D-seal.
- Using a wet finger finish the bead neatly.
- Remove excess silicone using a cloth.

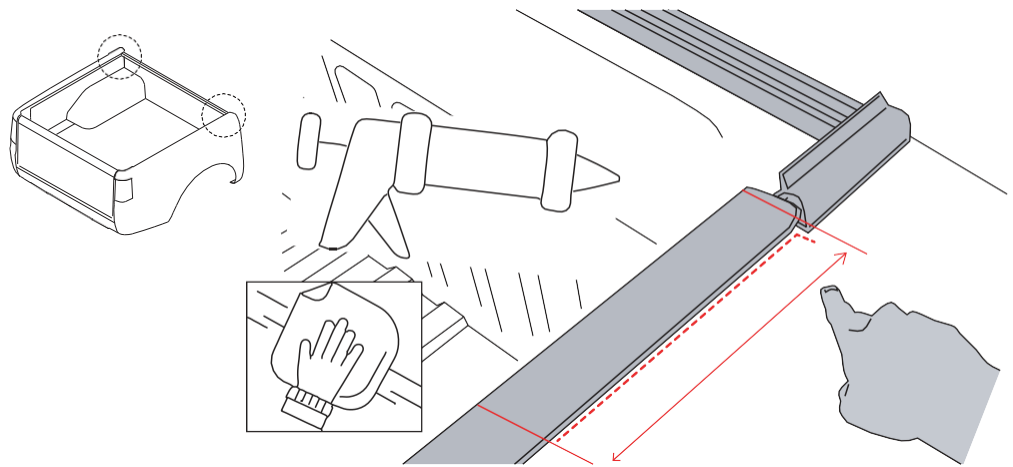

**! If installing a Sport Bar ensure all installation steps are complete before proceeding to next step !**

For ARB after market bar use kit 10058720

For Ford OEM bar (FOAMAB3J2155174BA) use kit 10058722

For Ford OEM FX4 bar use kit 10058724

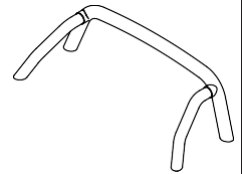

## Step 14

- Install item 4.0 onto items 6.0 & 6.1.

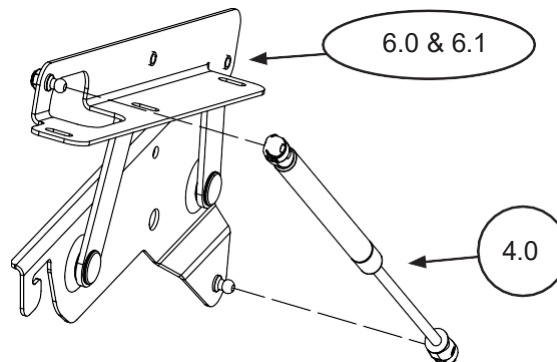

HardLid is supplied with 400N Gas Struts which are suitable for an unloaded lid. We recommend a maximum loading of 25 kgs when opening the lid. If you require your lid to remain open whilst loaded, you will need to purchase a Heavy Load Strut Upgrade kit which is available through your local service centre.

# FORD RANGER & MAZDA BT50 11+ FITTING INSTRUCTION

READ INSTRUCTIONS CAREFULLY BEFORE COMMENCING THIS ACTIVITY.

## Step 15

- Flip the lid over and attach the LHS & RHS (6.0 & 6.1) hinges, using items 7.0 & 7.1
- Ensure the inside edge of the hinge is offset from the inside of the frame by 7mm.
- Torque item 7.0 to **8Nm**.

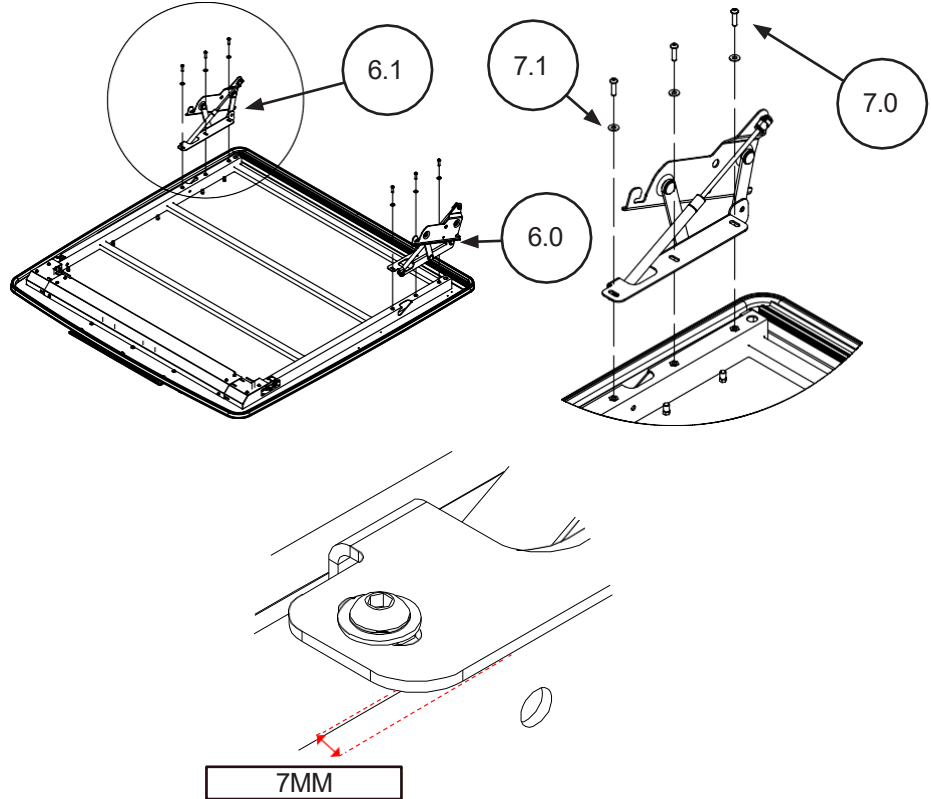

## Step 16

- Install the assembled lid onto the vehicle connector rails.
- 2 person lift required.
- Locate the hinges as per instruction.

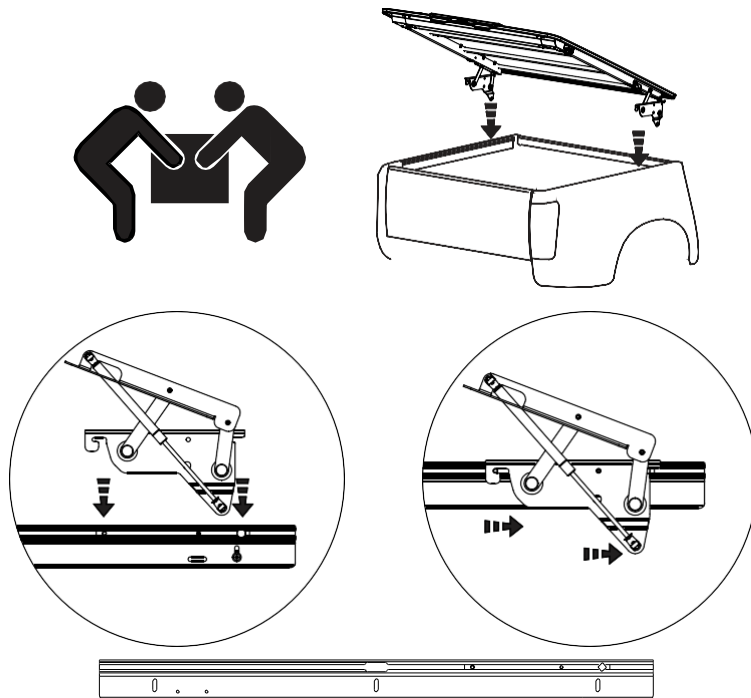

# FORD RANGER & MAZDA BT50 11+ FITTING INSTRUCTION

**READ INSTRUCTIONS CAREFULLY BEFORE COMMENCING THIS ACTIVITY.**

## Step 17

If the HardLid is exposed to high vibration situations i.e. extended periods of off road driving or applying loads on top of lid, it is recommended that the high vibration packers are installed.

- Tilt the bottom of hinge inward and slide the hinge packer (7.3) up and in behind the hinge. Locate it using the 16mm pilot hole.
- Fasten into position using item (7.2, 7.4 & 7.6). Torque item 7.2 & 7.6 to **8Nm**.
- Repeat for opposite side.

If parts are not installed ensure they are stored with the user manual.

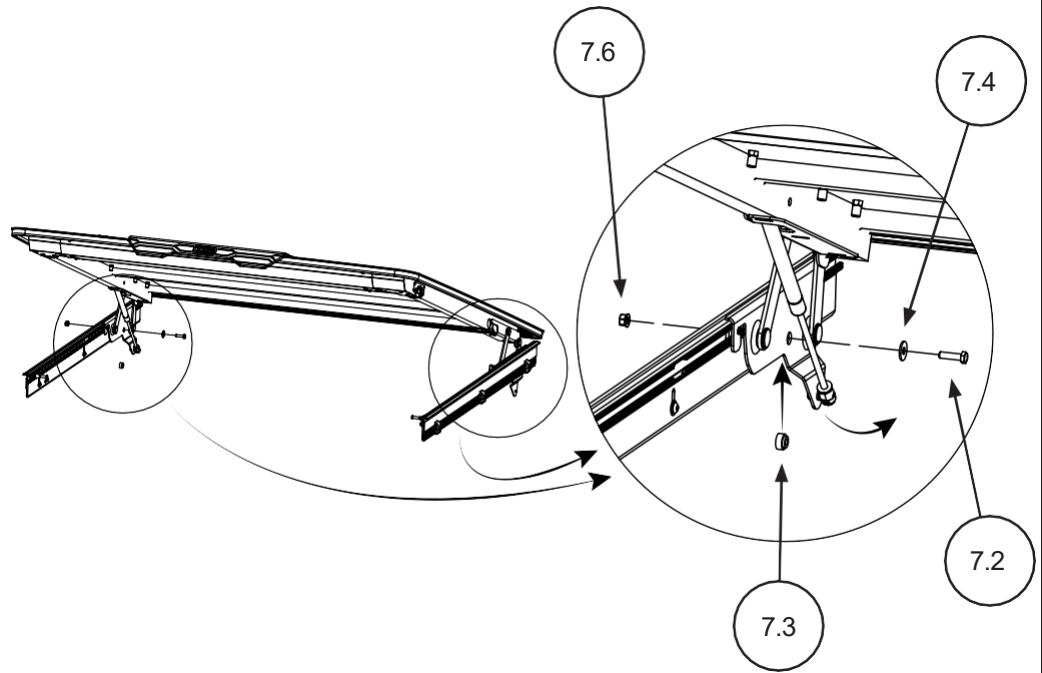

## Step 18

- Install washer (5.5) and thumbscrew (5.4).

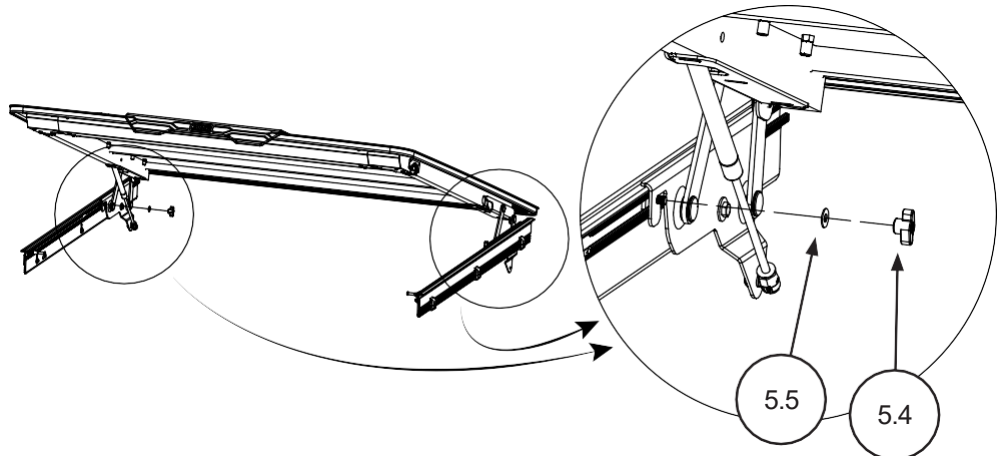

# FORD RANGER & MAZDA BT50 11+ FITTING INSTRUCTION

**READ INSTRUCTIONS CAREFULLY BEFORE COMMENCING THIS ACTIVITY.**

## Step 19

- Open the vehicle tailgate.
- Close the lid and align the strikers with the latches.
- Close the vehicle tailgate and close the lid again. Check to see that the weather seal is evenly contacting the vehicle surfaces around the perimeter of the vehicle tub.

Note: ensure the strikers fasteners are not tightened.

- Aim for 15-18mm gap between vehicle surfaces and lid.
- Once latch position is confirmed, tighten the strikers fasteners to **6NM**.

For best results align the pin with the rear of the latch to avoid interference with the latch body.

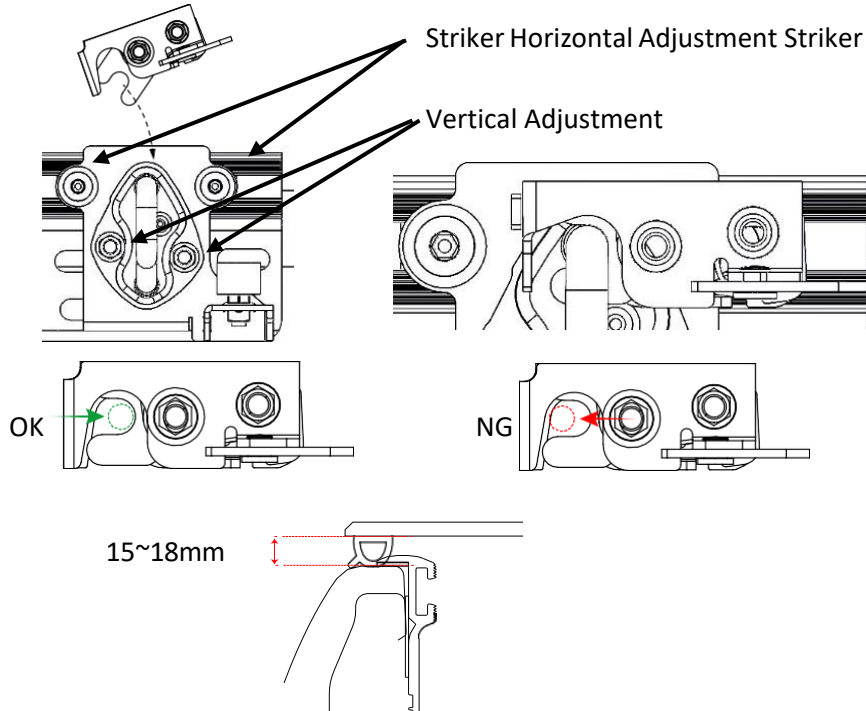

## Step 20

- Press rubber drip rail into drip rail channel.
- Ensure drip rail is securely locked into channel along full length.

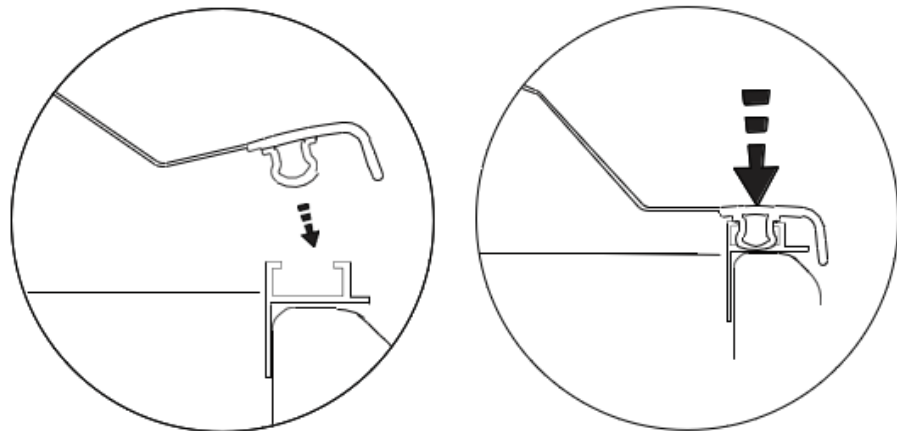

# FORD RANGER & MAZDA BT50 11+ FITTING INSTRUCTION

READ INSTRUCTIONS CAREFULLY BEFORE COMMENCING THIS ACTIVITY.

## Adjustment 1

- Check if the Hinges collide with vehicle connector rails.
- Adjust the hinge locations relative to the lid by loosening screws.
- Re-torque to **8Nm** once complete.

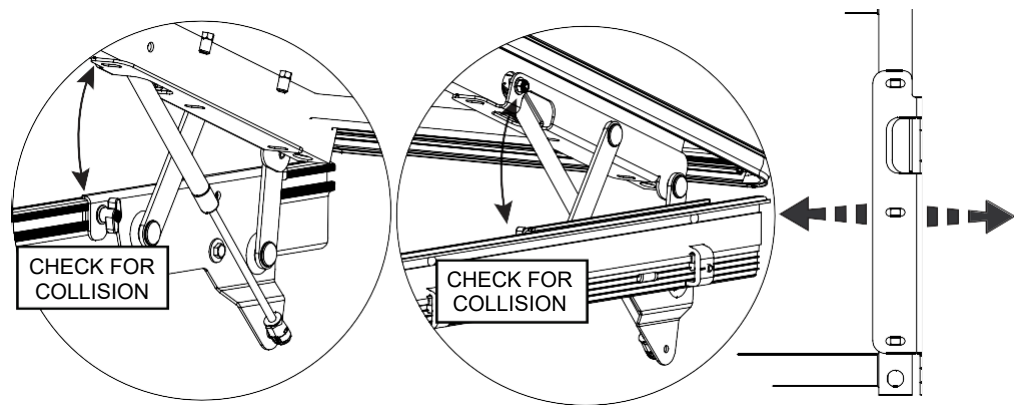

## Adjustment 2

- Check the alignment between lid and vehicle.
- If the lid is twisted the hinges can be shifted individually, forwards or backwards to fine tune the position of the lid.
- If the lid is sitting too far forward or too far rearward the hinges can be moved together.
- Loosen hinge fastening hardware.
- Wind the grub screw outward so that it sits flush with the hinge surface. This will allow you to adjust all components simultaneously.
- Shift the hinges in small increments and re-check offsets until satisfied.
- Once satisfied with position, tighten all fastening hardware.

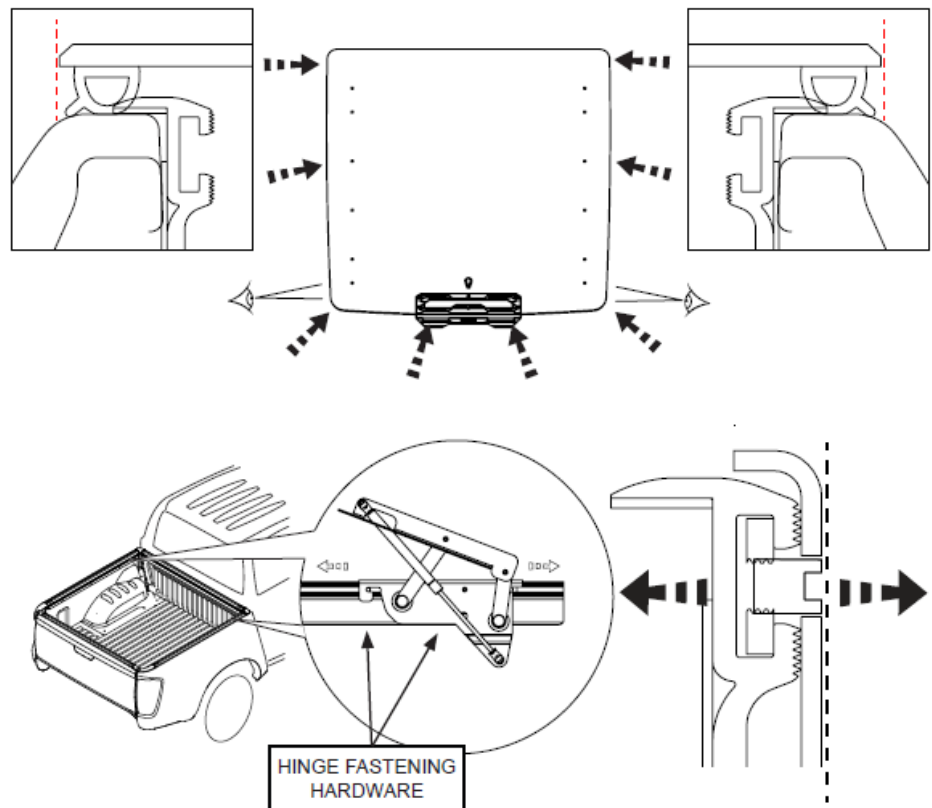

# FORD RANGER & MAZDA BT50 11+ FITTING INSTRUCTION

READ INSTRUCTIONS CAREFULLY BEFORE COMMENCING THIS ACTIVITY.

## Adjustment 4

- If latching sensitivity requires adjusting, cable tension can be increased or decreased.
- Loosen the lock nut and rotate the barrel adjuster anti-clockwise to increase cable tension or clock-wise to decrease cable tension.
- Ensure the lock nut is securely fastened.
- If there is insufficient adjustment at sides, see next step.

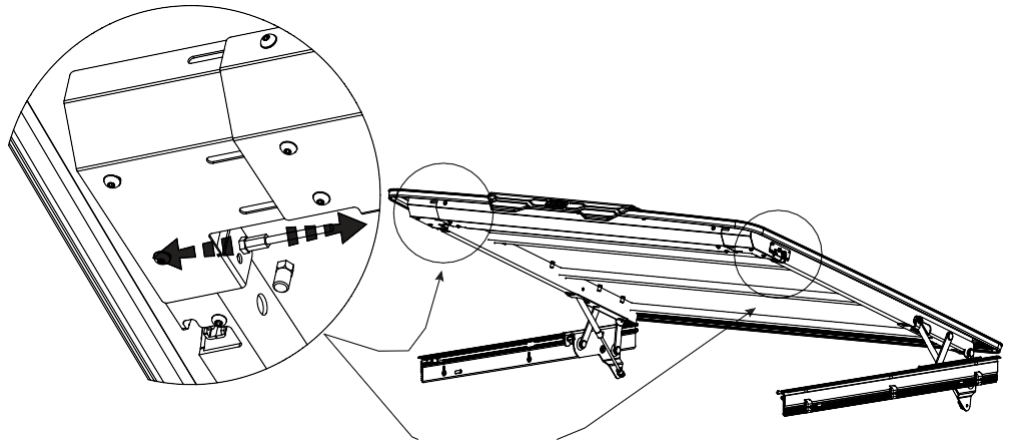

## Adjustment 5

- Remove the service cover.
- Loosen the lock nut and rotate the barrel adjuster anti-clockwise to increase cable tension or clock-wise to decrease cable tension.
- Adjust the cable tension so that the latches operate simultaneously.
- Ensure the lock nut is securely fastened.
- Re-install the service cover when finished.

