



4X4 ACCESSORIES

HARDLID UNIVERSAL FITTING INSTRUCTIONS

3 OF 3

Instruction # 37800606

HARDLID UNIVERSAL FITTING INSTRUCTIONS

READ INSTRUCTIONS CAREFULLY BEFORE COMMENCING THIS ACTIVITY.

General Notes

To aid in installation the correct order of installation needs to be followed:

1. Install all electrical components first (1 of 3) (electrical components are supplied separately)
2. Install Vehicle Tub Sealing Kit (2 of 3)
3. Install vehicle tub protective products such as tub liners*
4. Install styling bar onto HardLid
5. Install the HardLid Fitting Kit (3 of 3)
6. Install the HardLid (3 of 3)
7. Install any additional accessories such as roof racks.

**HardLid is compatible with under rail and Sport Guard style tub liners. Some trimming may be required. OEM liner compatibility cannot be guaranteed. Please contact your dealer for more information.*

- HardLid is supplied with 400N Gas Struts which are suitable for an unloaded lid. Recommended maximum loading of 25 kgs when opening the lid. If you require your lid to remain open whilst loaded, you will need to purchase a Heavy Load Strut Upgrade Kit which is available through your local dealer. Please use one of the following part numbers as a reference when contacting your dealer:

ARB NZ Part #	ARB AU Part #	Gas Strut N	
10056207	176202	450N	
10056209	176201	500N	

- Read through the fitting instructions before installation of accessory.
- Check that the contents of the Fitting Kit are complete and undamaged.
- If any contents of the Fitting Kit are found incomplete or damaged they must be replaced using the specified accessory components.
- Always install the accessory following the fitting instructions. Failure to do so may cause damage to the vehicle or the accessory and void the warranty.
- Ensure all recyclable discarded vehicle/accessory components and packaging are disposed following local recycling regulations.
- Safely store and protect any removed vehicle components.
- Ensure all bare metal surfaces are protected using Automotive Bare Metal Primer and touch-up paint.
- Remove all metal swarf and dust from all vehicle surfaces.
- Ensure all fasteners are torqued to the specifications as per instruction.
- Apply any adhesives to the vehicle only when the surface temperature is between 20°C to 40°C.
- **Bedliner:** Recommended rust preventative solution be applied to vehicle surfaces before installation.

General Vehicle and Accessory Warranty Notes and Cautions



- For correct installation and proper operation of the vehicle and accessory we recommend this accessory is fitted by a qualified Technician.
- During the accessory fitment ensure all automotive safety practices and regulations are followed.
- Do not modify the vehicle in any way other than specified in these Accessory Fitting Instructions as this may void the warranty.



Safety Notes

- Check that all work practises comply with safety standards.
- It is advisable to seek assistance from another person when lifting heavy components.
- While using power tools ensure safe procedures are followed.
- Appropriate clothing & PPE must be worn.

HARDLID UNIVERSAL FITTING INSTRUCTIONS

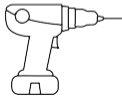

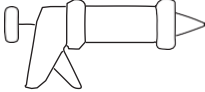
READ INSTRUCTIONS CAREFULLY BEFORE COMMENCING THIS ACTIVITY.



No.	Description	Image
Tools Required		
1	METRIC HEX KEY SET	
3	METRIC SPANNER SET	
5	CLEANING RAGS	
7	POWER DRILL & 5MM DRILL BIT	

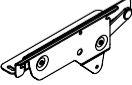

No.	Description	Image
Tools Required		
2	METRIC RULER	
4	CLEAR NON-ACETIC SILICONE	
6	TORQUE WRENCH	
8		

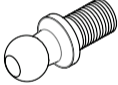
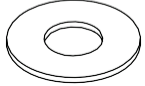

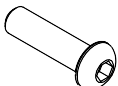
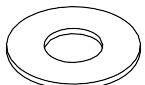

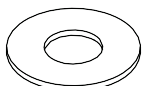
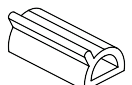

HARDLID UNIVERSAL FITTING INSTRUCTIONS

READ INSTRUCTIONS CAREFULLY BEFORE COMMENCING THIS ACTIVITY.

No.	Service part No.	QTY	Image
4. Hinges			
Note: Items 4.2 - 4.4 are pre-assembled as part of 4.0 & 4.1 Ensure that sub assemblies contain all parts before commencing installation.			
4.0	10057826 LEFT HINGE ASSEM	1	
4.1	10057827 RIGHT HINGE ASSEM	1	
4.2	10056199 NUT M8 NYLOC	4	
4.3	10056204 BALL STUD	4	
4.4	10003717 WASHER FLAT M8X19X1.2MM	4	

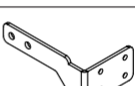
5. General Hardware			
5.0	10053299 M8X30MM B/HEAD	6	
5.1	10003717 WASHER FLAT M8X19X1.2MM	6	
5.2	10056261 M8X30MM SCREW	2	
5.3	10055927 STEP SPACER	2	
5.4	10055714 M8X24X2MM	2	
5.5	10000091 SEAL	0.2	

No.	Service part No.	QTY	Image
5.6	10055835 NUT HEX FLANGE M8	2	
5.7	10053982 BLACK RIVET	8	

6. Miscellaneous			
Note: Items 6.0 & 6.1 are vehicle specific.			
6.0	10058129 Toyota, Isuzu & Mazda	1	
	10058180 Nissan	1	
6.1	10058130 Toyota, Isuzu & Mazda	1	
	10058181 Nissan	1	
6.2	10055553 M8X10MM GRUB SCREW	4	
6.3	10057955 OWNERS MANUAL	1	

HARDLID UNIVERSAL FITTING INSTRUCTIONS

READ INSTRUCTIONS CAREFULLY BEFORE COMMENCING THIS ACTIVITY.

Step 1

- Set distance of item 3.2 according to **TABLE 1**.
- Torque item 3.3 to **8NM**.
- Repeat for opposite side.

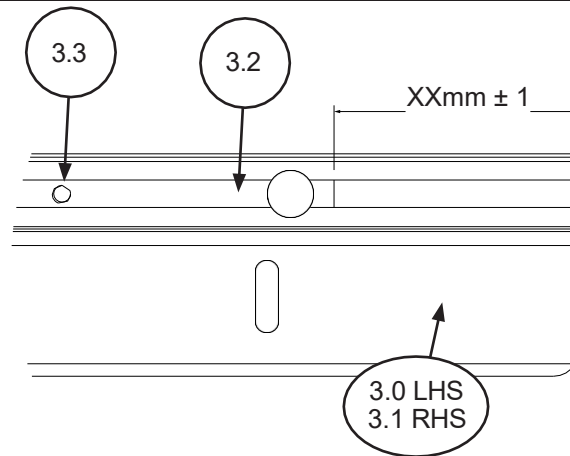

Vehicle Model	Distance (mm)
Toyota 15+	98mm
Isuzu & Mazda 20+	88mm
Nissan 21+	88mm
Isuzu 24+	103mm

Step 2

- Insert items 6.0 & 6.1 into the end of 3.0 & 3.1. Loosely secure using items 6.2.
- Loosely attach VCRs 3.0 & 3.1 to vehicle using items 3.5, 3.6 & 3.7.

Note: Items 6.0 & 6.1 sit in front of the sealing channel for Nissan Navara.

- Make sure VCRs are in the correct orientation, item 3.2 located at the front of the vehicle.

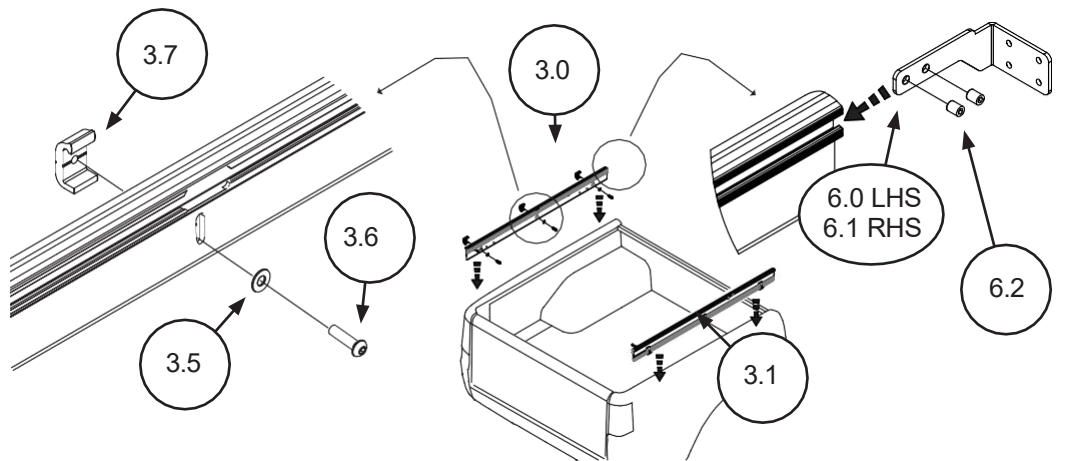

Step 3

- Position item 3.0 & 3.1 according to **Table 2**.

Note: Isuzu & Mazda have a step on the inside of the front header rail. Measurement to be taken from step face.

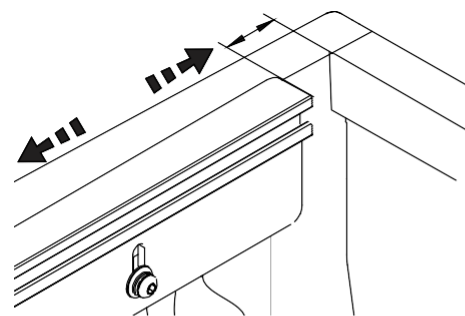

Vehicle Model	Distance (mm)
Toyota 15+	50mm
Isuzu & Mazda 20+	50mm
Nissan 21+	50mm
Isuzu 24+	50mm

Note: Isuzu & Mazda measured from face indicated.

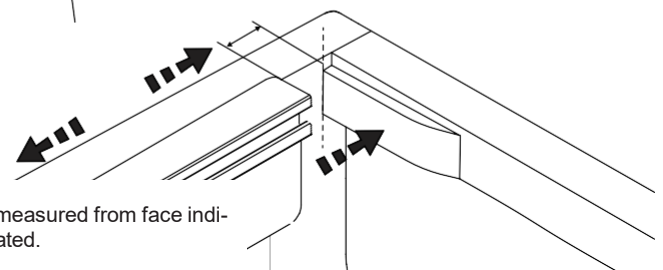

HARDLID UNIVERSAL FITTING INSTRUCTIONS

READ INSTRUCTIONS CAREFULLY BEFORE COMMENCING THIS ACTIVITY.

Step 4

- Ensure VCRs (3.0 & 3.1) are sitting perpendicular to the top of the vehicle rails.
- Locate C-clamps (3.7) according to **TABLE 3**. Apply downward pressure to the VCR and tighten item (3.6) to **8Nm**.
- Ensure foam is contacting vehicle surface along entire length of rail.

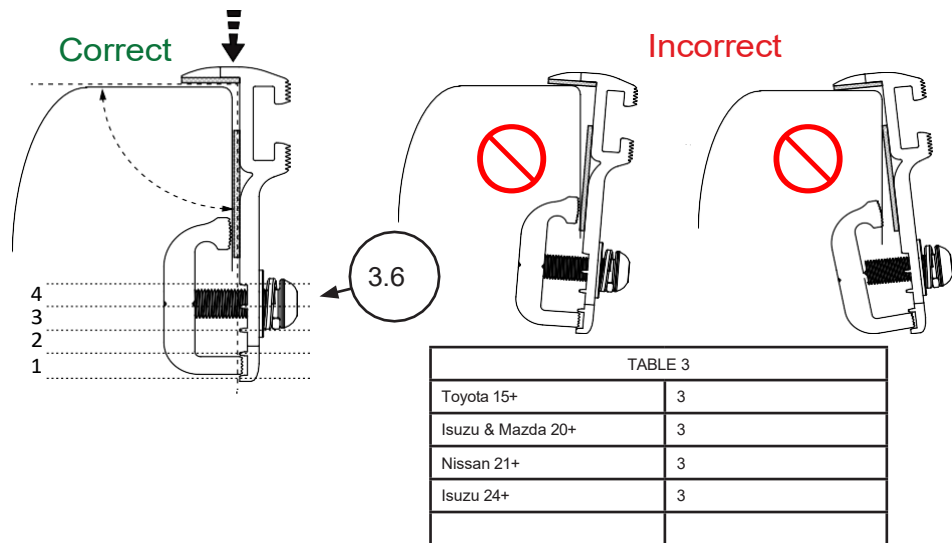

Step 5

- Push item 6.0 & 6.1 hard up against the front rail
- Note: Items 6.0 & 6.1 sit in front of the sealing channel for Nissan.
- Tighten item 6.2 to **8Nm**.

OPTIONAL: Drill and rivet items 6.0 & 6.1 to front rail of vehicle. Note, drilling into vehicle body may void vehicle warranty. Use item 5.7 x 4.

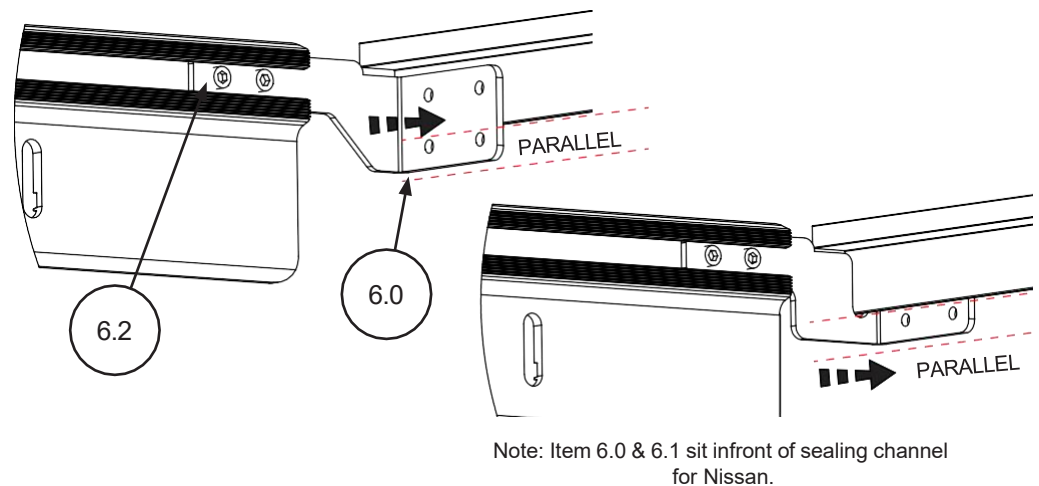

Step 6

- Carefully measure the distance between VCR 3.0 & 3.1 and the front edge of the Sealing Channel.
- Cut D-Seal, item 5.5 into two identical portions according to dimension X.

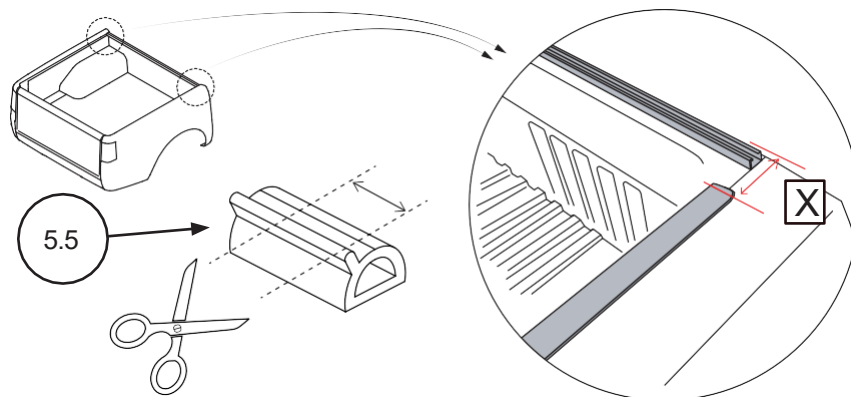

HARDLID UNIVERSAL FITTING INSTRUCTIONS

READ INSTRUCTIONS CAREFULLY BEFORE COMMENCING THIS ACTIVITY.

Step 7

- Clean & prime the vehicle rail.
- Ensure item 5.5 is orientated with the rib facing into the vehicle deck.
- Align the edge of item 5.5 with the inside face of the vehicle rail.
- Push the seal hard up against the Sealing Channel & VCR and ensure there are no gaps between the parts.

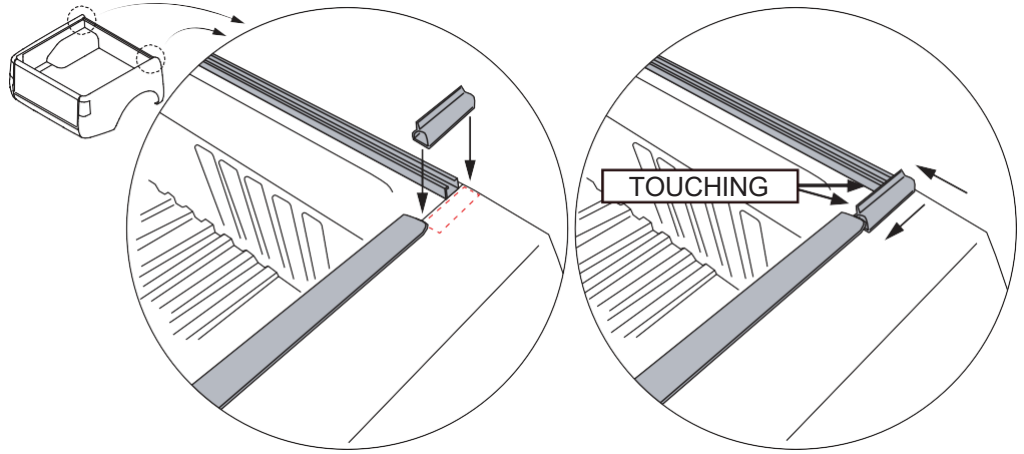

Step 8

- Fill internal edges between D-seal and drip rail mounting rail with silicone.
- Clean excess silicone with a cloth.

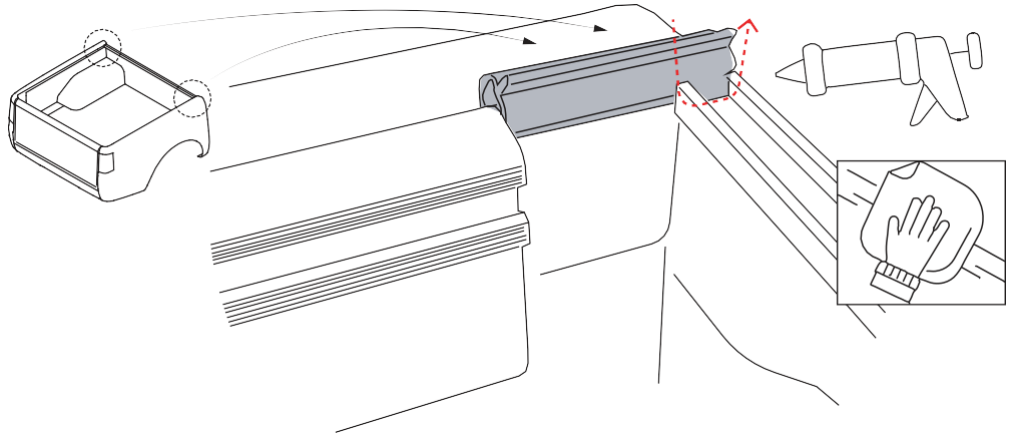

Step 9

- Run a bead of silicone approximately 150mm along edge of VCR and into the joint between the D-seal.
- Using a wet finger finish the bead neatly.
- Remove excess silicone using a cloth.

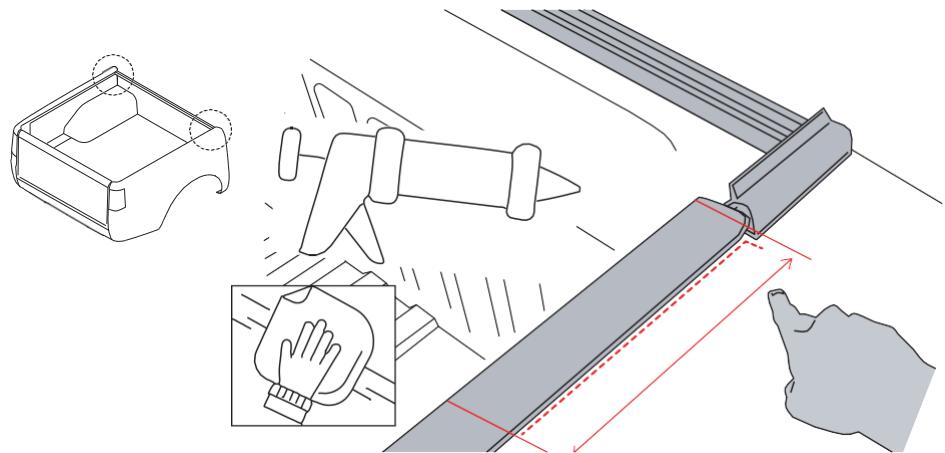

HARDLID UNIVERSAL FITTING INSTRUCTIONS

READ INSTRUCTIONS CAREFULLY BEFORE COMMENCING THIS ACTIVITY.

! If installing a Sport Bar ensure all installation steps are complete before proceeding to next step !

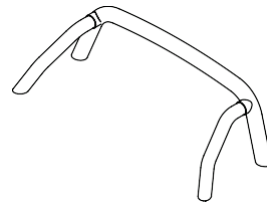

Step 10

- Install item 2.0 onto items 4.0 & 4.1.

HardLid is supplied with 400N Gas Struts which are suitable for an unloaded lid. We recommend a maximum loading of 25 kgs when opening the lid. If you require your lid to remain open whilst loaded, you will need to purchase a Heavy Load Strut Upgrade kit which is available through your local service centre.

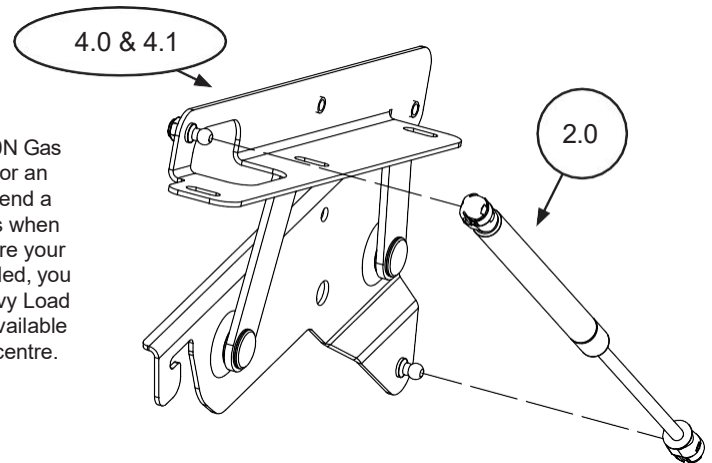

Step 11

- Flip the lid over and attach the LHS & RHS (4.0 & 4.1) hinges, using items 5.1 & 5.0.
- Ensure the inside edge of the hinge is offset from the inside of the frame according to **TABLE 4**.
- Torque item 5.0 to **8Nm**.

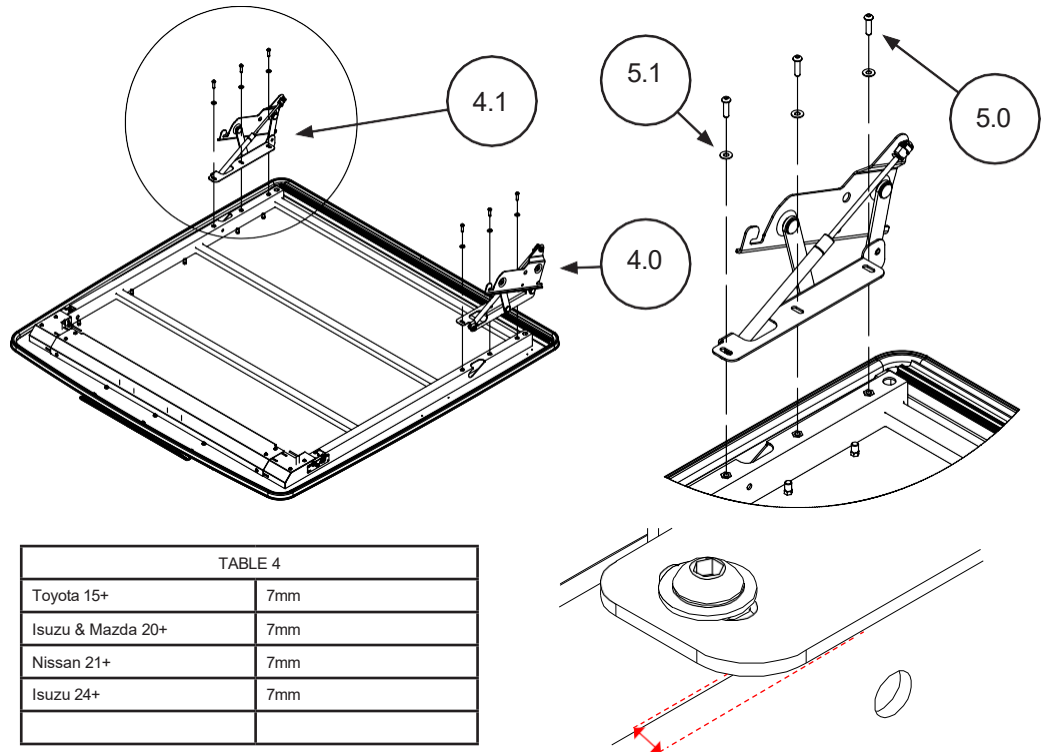

Vehicle Model	Offset
Toyota 15+	7mm
Isuzu & Mazda 20+	7mm
Nissan 21+	7mm
Isuzu 24+	7mm

HARDLID UNIVERSAL FITTING INSTRUCTIONS

READ INSTRUCTIONS CAREFULLY BEFORE COMMENCING THIS ACTIVITY.

Step 12

- Install the assembled lid onto the vehicle connector rails.
- 2 person lift required.
- Locate the hinges as per instruction.

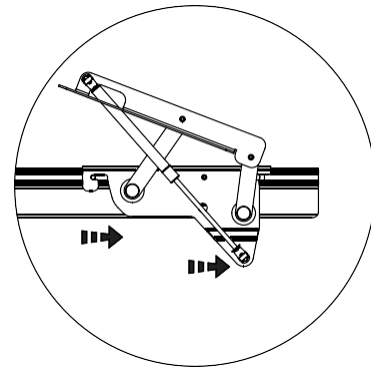
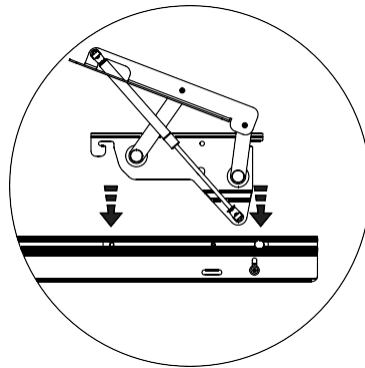
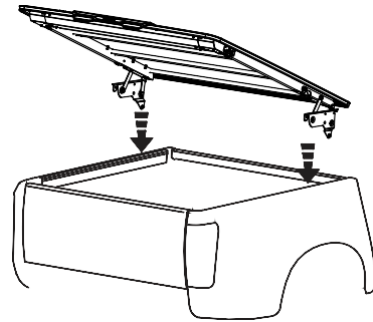

Step 13

OPTIONAL STEP

If the HardLid is exposed to high vibration situations i.e. extended periods of off road driving, it is recommended that the high vibration packers are installed.

- Tilt the bottom of hinge inward and slide the hinge packer (5.3) up and in behind the hinge. Locate it using the 16mm pilot hole.
- Fasten into position using item (5.2, 5.4 & 5.6). Torque item 5.2 & 5.6 to **8Nm**.
- Repeat for opposite side.

If parts are not installed ensure they are stored with the user manual.

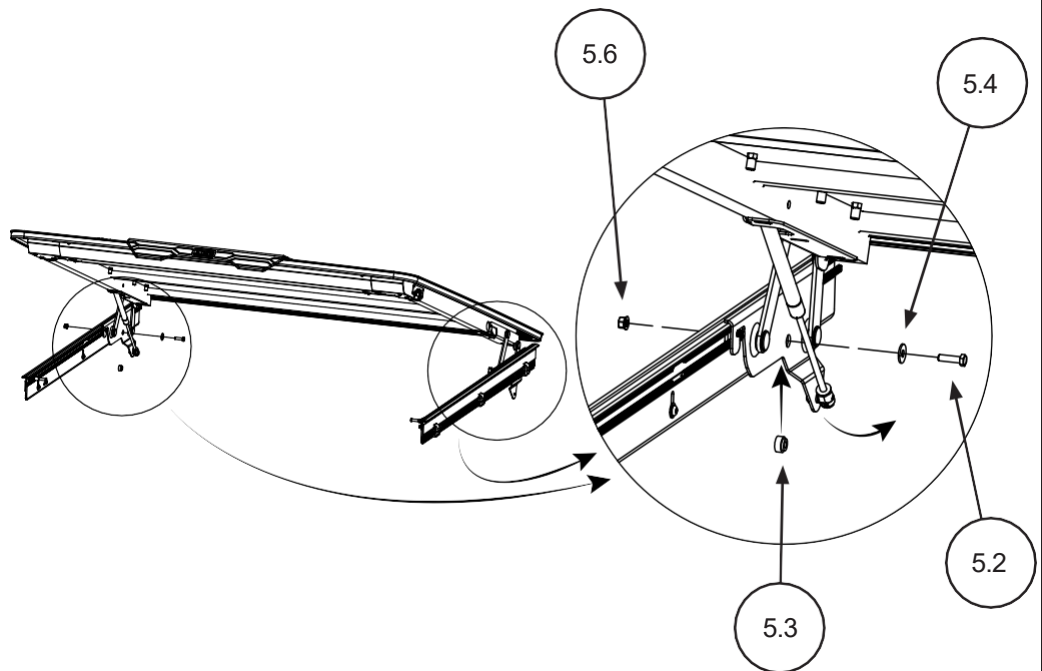

HARDLID UNIVERSAL FITTING INSTRUCTIONS

READ INSTRUCTIONS CAREFULLY BEFORE COMMENCING THIS ACTIVITY.

Step 14

- Install washer (3.6) and thumbscrew (3.4).

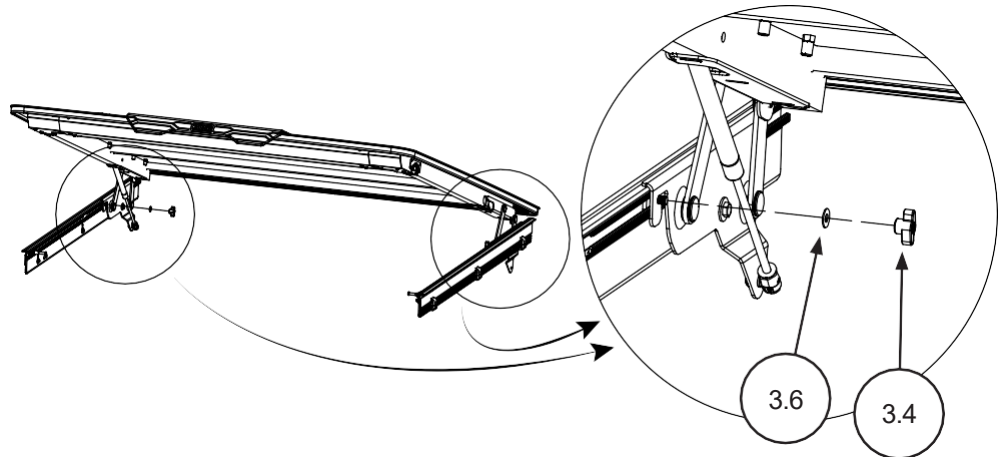

Step 15

- Open the vehicle tailgate.
- Close the lid and align the strikers with the latches.
- Close the vehicle tailgate and close the lid again. Check to see that the weather seal is evenly contacting the vehicle surfaces around the perimeter of the vehicle tub.

Note: ensure the strikers fasteners are not tightened.

- Aim for 15-18mm gap between vehicle surfaces and lid.
- Once latch position is confirmed, tighten the strikers fasteners to **6NM**.

For best results align the pin with the rear of the latch to avoid interference with the latch body.

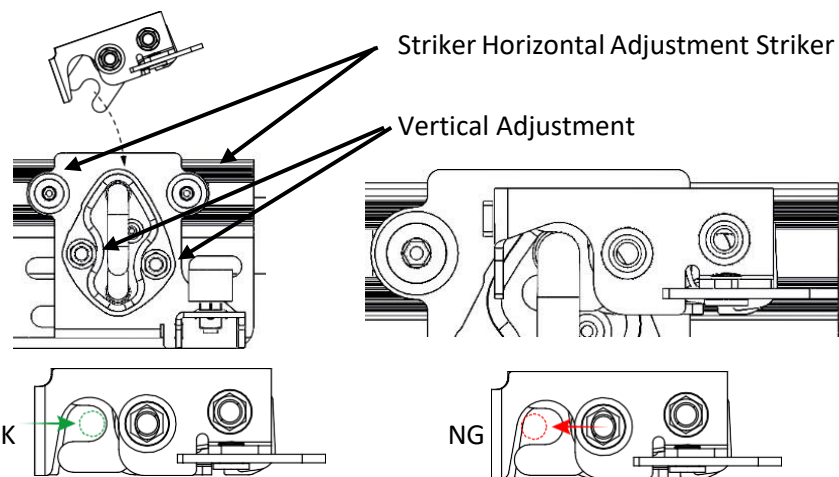

15~18mm

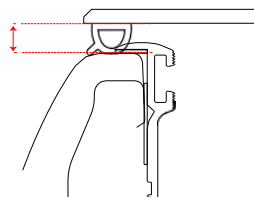

HARDLID UNIVERSAL FITTING INSTRUCTIONS

READ INSTRUCTIONS CAREFULLY BEFORE COMMENCING THIS ACTIVITY.

Step 16

- Press rubber drip rail into drip rail channel.
- Ensure drip rail is securely locked into channel along full length.

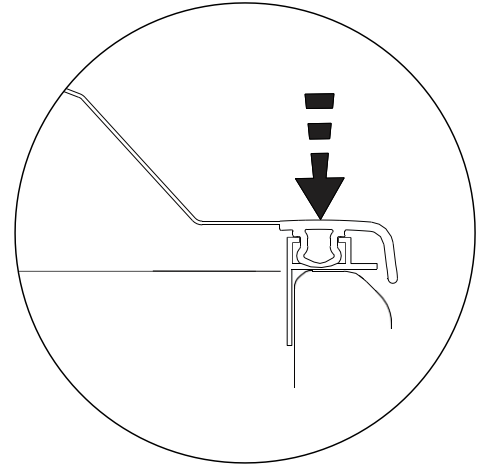
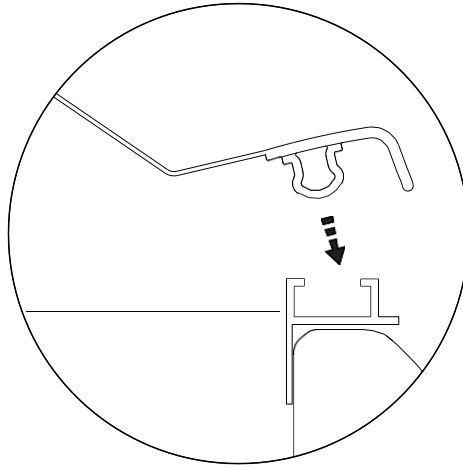

HARDLID UNIVERSAL FITTING INSTRUCTIONS

READ INSTRUCTIONS CAREFULLY BEFORE COMMENCING THIS ACTIVITY.

Adjustment 1

- Check if the Hinges collide with vehicle connector rails.
- Adjust the hinge locations relative to the lid by loosening screws.
- Re-torque to **8Nm** once complete.

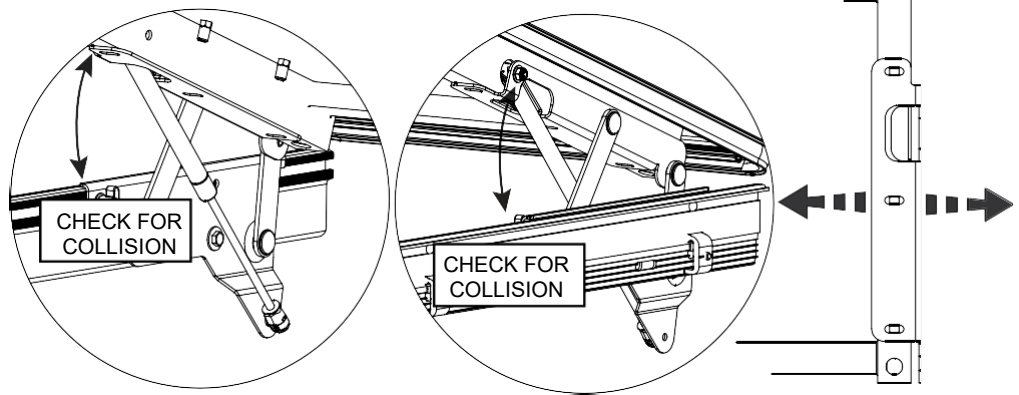

Adjustment 2

- Check the alignment between lid and vehicle.
- If the lid is twisted the hinges can be shifted individually, forwards or backwards to fine tune the position of the lid.
- If the lid is sitting too far forward or too far rearward the hinges can be moved together.
- Loosen hinge fastening hardware.
- Wind the grub screw outward so that it sits flush with the hinge surface. This will allow you to adjust all components simultaneously.
- Shift the hinges in small increments and re-check offsets until satisfied.
- Once satisfied with position, tighten all fastening hardware.

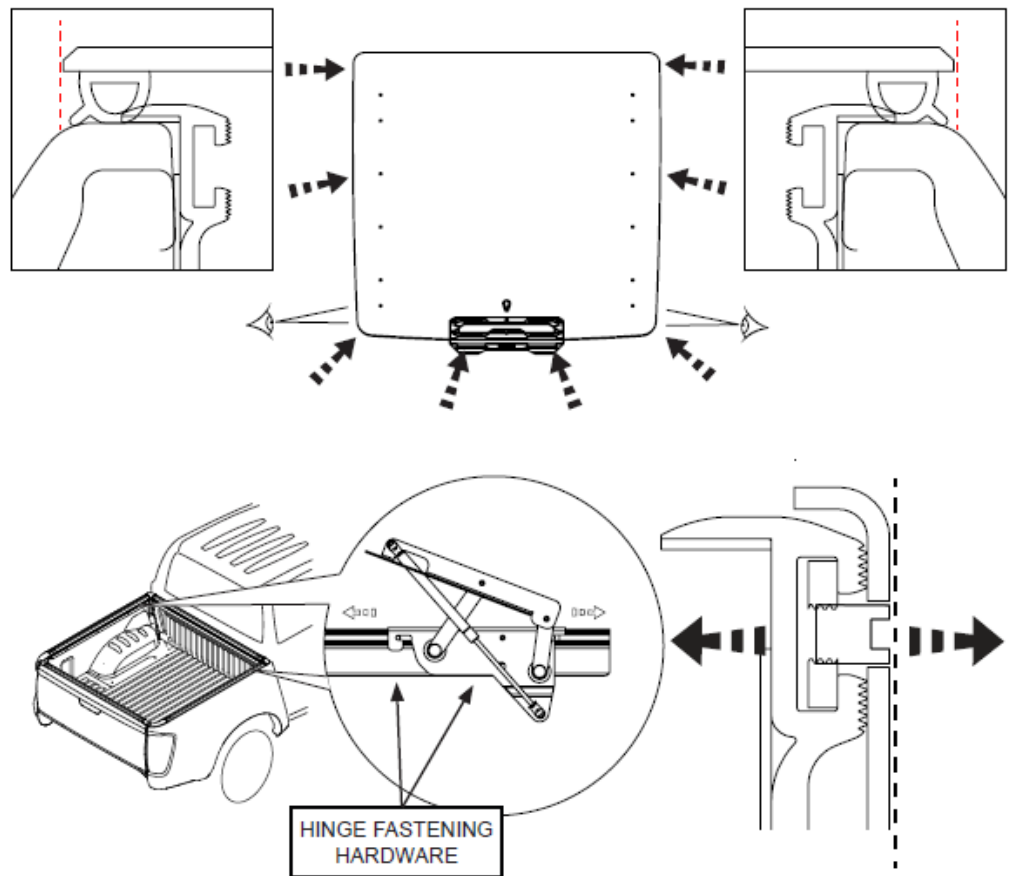

HARDLID UNIVERSAL FITTING INSTRUCTIONS

READ INSTRUCTIONS CAREFULLY BEFORE COMMENCING THIS ACTIVITY.

Adjustment 4

- If latching sensitivity requires adjusting, cable tension can be increased or decreased.
- Loosen the lock nut and rotate the barrel adjuster anti-clockwise to increase cable tension or clock-wise to decrease cable tension.
- Ensure the lock nut is securely fastened.
- If there is insufficient adjustment at sides, see next step.

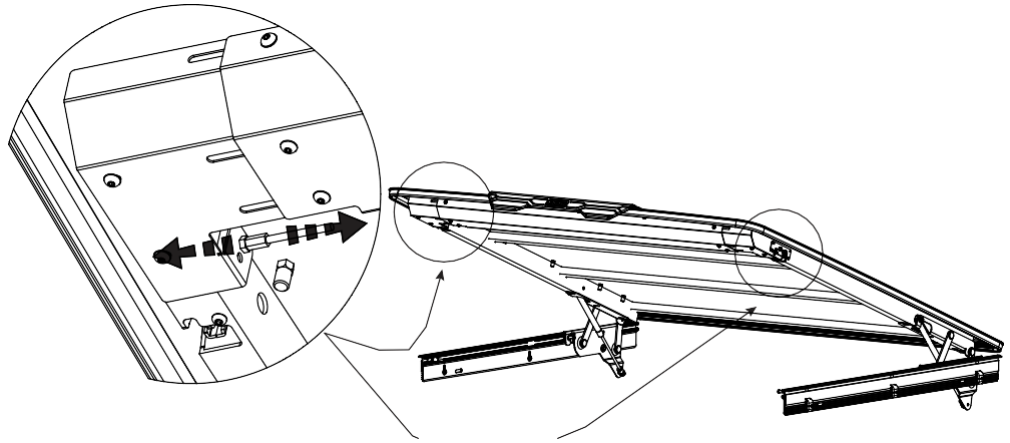

Adjustment 5

- Remove the service cover.
- Loosen the lock nut and rotate the barrel adjuster anti-clockwise to increase cable tension or clock-wise to decrease cable tension.
- Adjust the cable tension so that the latches operate simultaneously.
- Ensure the lock nut is securely fastened.
- Re-install the service cover when finished.

