

ARB - CLASSIC PLUS CANOPY

XCLS18 - Mitsubishi Triton Dual Cab 2024+

XCLS19 - Nissan Navara Dual Cab 2026+

Central Locking Rear Door Canopy



FITTING KITS: TAILGATE AND HEAD BOARD KIT 6178340. TUB MOUNT KIT 6178310 & 6178553. SEAL KIT 6171422

! PLEASE PROVIDE A COPY OF THESE INSTRUCTIONS TO THE CUSTOMER !

IMPORTANT:

- Vehicle bodies and vehicle specific installation can vary. Please read the following instructions as they refer to important information which could affect the quality of the final installation.
- It is advisable to have the canopy fitted by an authorised dealer.
- Most of the installation can be completed by one person (**however 2 people will be required to lift the canopy onto the vehicle**).

FITMENT:

- For Bed Liners additional time for fitting is required and trimming of bed liners is required. **Fitting with under rail bed liners is recommended ONLY. Tailgate liners will require trimming to remove any cap over the tailgate. to suit the canopy's door stop sealing assembly mounted to the tailgate.**
- Roll top tonneaus, Cabin Guards and Sports bars **must** be removed prior to canopy fitment. These components can be returned to the customer if required.
- When fitting the ARB canopy vent, fitment of the vent is easier prior to fitting the canopy to the vehicle and before internal frame installations. **The vent must be fitted to the front of the canopy if a roof rack is to be fitted.**

CARE OF YOUR CANOPY:

Please refer to the “Owner’s Manual Supplement” to be given to the purchaser on installation, as per the details referred to in the second last page of these fitting instructions.

HAVE AVAILABLE THESE SAFETY ITEMS WHEN FITTING PRODUCT:

Protective eyewear		Hearing protection	
--------------------	---	--------------------	---

NOTE: ‘WARNING’ notes in the fitting procedure relate to OHS situations, where to avoid a potentially hazardous situation it is suggested that protective safety gear be worn or a safe work procedure be employed. If these notes and warnings are not heeded, injury may result.

TOOL LIST FOR FITMENT:

<ul style="list-style-type: none">• Torque Wrench 0-25Nm• Sockets ¼”, 8,10 & 13mm, socket extension bar and driver• Spanners, ratchet type, 8, 10 and 13mm.• T30 and T40 Torx Driver• Tape measure• 150mm ruler• Knife• Sharp scissors• Flat file• Angle grinder• Die grinder• Metal primer touch up paint• Engineer’s scribe• Sheet metal vice grip clamp• Quicklock G clamp	<ul style="list-style-type: none">• Wax and grease remover• Silicon Caulking Gun• Neutral cure Non-Acetic Silicon• Phillips head screwdrivers• Flat blade screwdrivers• Side Cutters• Wire stripping tool• Electrical crimping tool• Non-permanent marker• Electrical tape• Masking tape• Cleaning cloths / rags• Jig saw / hacksaw for bedliners.
---	--

FITTING THE CANOPY IS UNDERTAKEN THE FOLLOWING STAGES:

1. Removing any sports bars, cabin guards, sail planes and roll top tonneau covers.
2. Fitting the tailgate door sealing stop assembly.
3. Sealing the front corners of the tub, front header rail and canopy mounting bracket installation.
4. Fitting the bed seal before the canopy is mounted.
5. Fitting the canopy to the vehicle.
6. Fitting wiring.
7. Operational checks and adjustment options for doors and windows.
8. Recording of key code and owner’s manual supplement.
9. Check list and sign off.

!! IMPORTANT !! other than specifically specified in this instruction

REQUIRED SCREW TORQUES: M6=9Nm M8=20Nm Clamps bolts to tub=16Nm

SCREW TORQUES: These must be adhered to avoid warranty issues and should be checked at vehicle service intervals.

THE FITTING KIT CONTAINS:















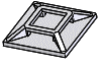

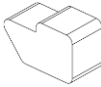
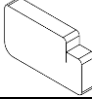
Packed under the canopy are 3 fitting kits:

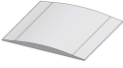







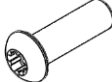
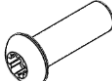

6178340 contains the tailgate door stop sealing kit and tub front head board mounting rail.

6178310 contains the main hardware for mounting the canopy.

6178553 contains the hardware for the front corners of the tub when fitting to a vehicle with an OE roll top and sailplane

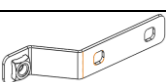
6171422 contains the tub bed rail sealing extrusion.

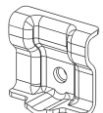
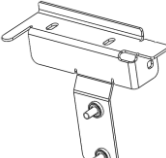
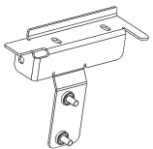
Kit No	Part No	Picture	Qty	Description
1). 6178340 TAILGATE AND HEAD BOARD KIT	664255		1	BRACKET- FRONT HEAD RAIL ASSEMBLY
	667AQ001		1	RUBBER- DOOR SEALING TUB STOP ASSEMBLY
2). 6178310 MAIN CANOPY HARDWARE KIT	6821135		1	TUBE CONVOLUTED 7mm x 250mm LONG
	3199779		2	GRINDING PLATE (DISPOSABLE)
	6821293		1	CABLE TIE BASE
	665076		1	BUMPON STRIP OF 5 PIECES
	669PB005		1 PAIR	DIE CUT - PAIR- FOAM FRONT TUB CORNER SEALING BLOCKS
	665083		1 PAIR	DIE CUT - FOAM SEAL PAIR FOR TAILGATE SEALING BRACKETS 12MM THICK
	668PB006		2 PAIR	DIE CUT BLACK STICKERS
	668PM005		1 PAIR	RUBBER SELF ADHESIVE TUB CORNER SEAL BRIDGES
	665044		3	PRIMER STICK
	6602018		4	ALCOHOL WIPES
	669PJ025		1	ELECTRICAL LOOM VEHICLE CANOPY PATCH HARNESS
	668PB015		2	FOAM ANTI RATTLE 30mmx150mm STRIPS
	668PJ015		1	ELECTRICAL RELAY BOX
	180302		12	CABLE TIES 200mm LONG
	655082		1 PAIR	DIE CUT FRONT TUB TOP SEALS

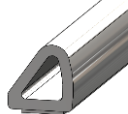
	4581303		10	M8 x 25.4 OD x 3 WASHER -- BLACK
	6151625		14	M8 x 25 TORX BUTTON HEAD SCREW – BLACK (T40)
	6152116		4	M8 x 40 TORX BUTTON HEAD SCREW – BLACK (T40)
	4584393		16	M8 X 19OD X 2mm FLAT WASHER BLACK (for clamp bolts)
	6151212		8	M8 BLACK NYLOC NUT
	669PB004		4	CLEAR DIE CUT PROTECTION FILM 80X64MM
	667PE006R		1	RIGHT HAND RUBBER TUB SIDE SEAL
	667PE006L		1	LEFT HAND RUBBER TUB SIDE SEAL
	669AQ041		2	NUT PLATE - FRONT HEADRAIL
	669AQ040		2	BRACKET- FRONT HEADER RAIL SUPPORT
	669AQ037		4	BRACKET- CLAMP TUB LIP OUTER
	669AQ036		4	BRACKET- CLAMP TUB LIP INNER
	669AQ035R		1	RIGHT HAND FRONT TUB CORNER BRACKET ASSY
	669AQ035L		1	LEFT HAND FRONT TUB CORNER BRACKET ASSY
3). 6178553 FITTING KIT FOR VEHICLES WITH OE ROLL TOP AND SAILPLANE	6178553		1	Additional kit for vehicles with an OE Roll top tonneau cover and sailplane. (Contains Instructions 37800359)
4). 6171422 CANOPY SEAL KIT 5M	6602018		4	ALCHOL WIPES
	9009177		5 METERS	BEDRAIL SEAL

SECTION 1: PREPARING THE VEHICLE TUB – REMOVAL OF SPORTS BARS, BED RAIL PLASTIC CAPS, CABIN GUARDS AND ROLL TOP TONNEAU COVERS.

1. Remove any sports bars, cabin guards, sailplanes or roll top tonneaus fitted and return any items to the customer if requested to do so.
2. **Bed liners DO NOT require removal based on OEM supplied products. However, tailgate liners if have a cap over the tailgate will need to be trimmed off.**

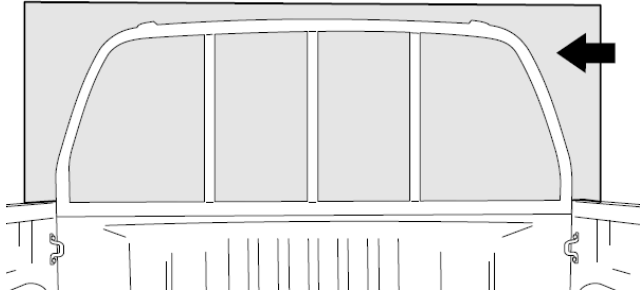
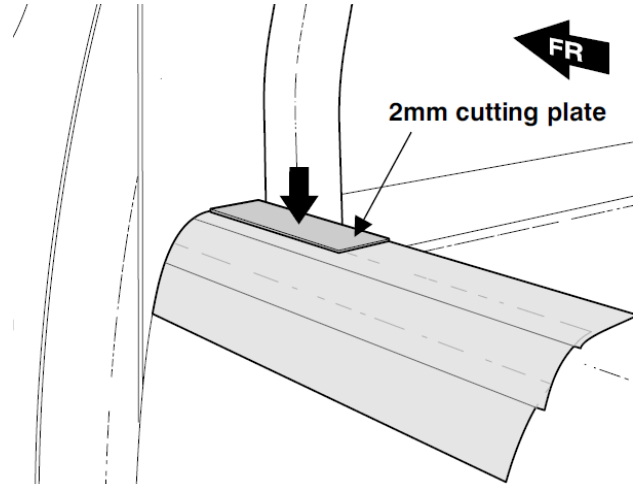
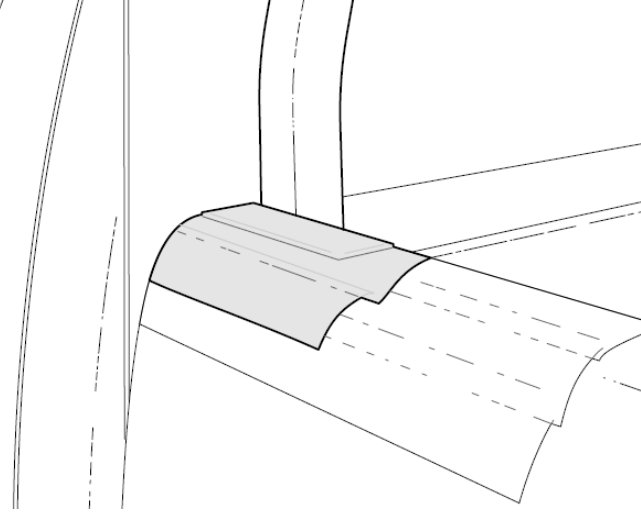
	<p>1.0) If your vehicle is fitted with a cabin guard frame it must be removed.</p> <p>1.1) Slide a sheet of cardboard of similar between the cab and Ute body.</p>
	<p>1.2) Apply 200mm lengths of overlapping masking tape to the top and side of the tray, up to the cabin guard main support leg on both sides of the tub.</p> <p>1.3) Position the steel protective grinding plates (3199779) (2mm thick) next to the cabin guard main support leg on both sides of the tub.</p>
	<p>1.4) Secure the protective steel grinding plate to the tray body by covering it completely with masking tape as shown.</p>

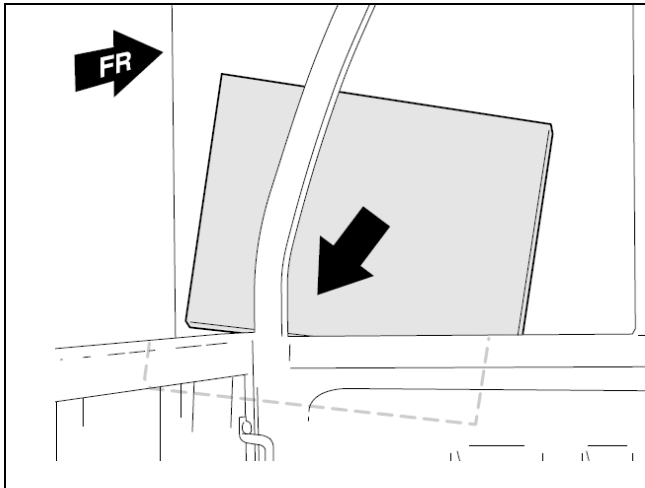

1.5) Insert a suitable protective wooden board of adequate thickness between the cardboard and the cabin guard main brace as shown.



1.6) Using a medium sized angle grinder, partially cut through the rear and side faces of the cabin guard main support legs and gusset support bracket on both sides of the vehicle

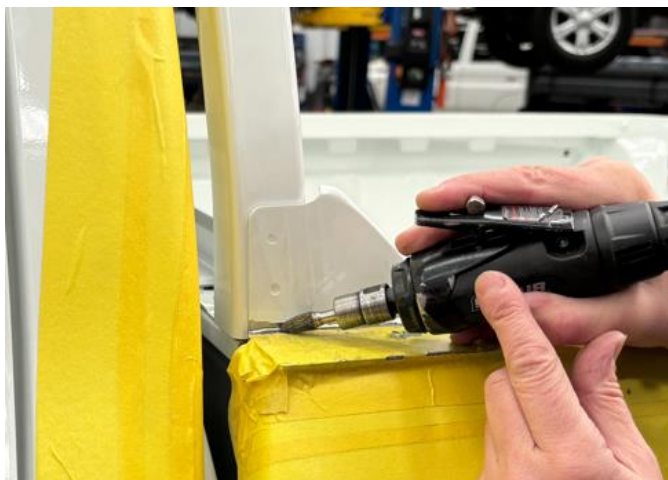

1.7) Using a die grinder, cut through the portion of the cabin guard closest to the back of the cabin on both sides of the vehicle.

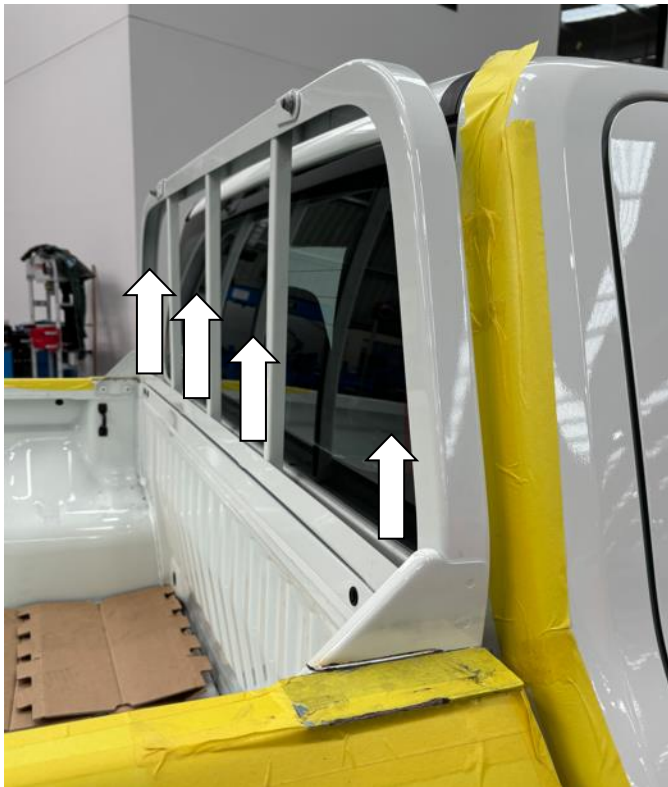

- 1.8) Unbolt in 4 places and remove the cabin guard from the vehicle

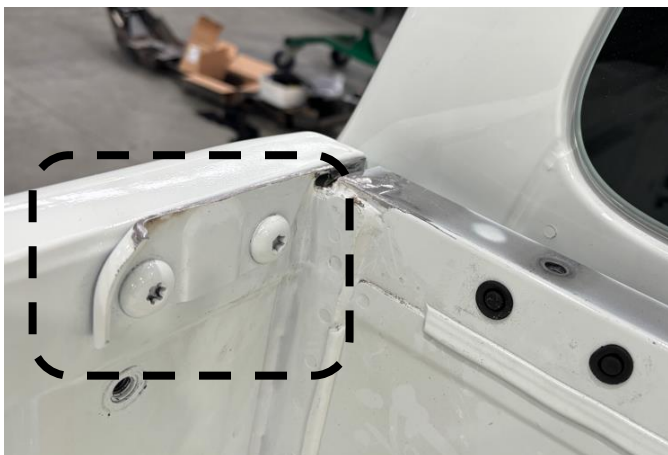

- 1.9) This will leave the lower gusset brackets from the cabin guard still attached to the side of the tub. These are to remain in place on the tub. Grind the remaining areas of the cabin guard flush with the top of the tub side and the with the front head board top face of the tub





1.10) Finish these areas on both sides with a flat file.

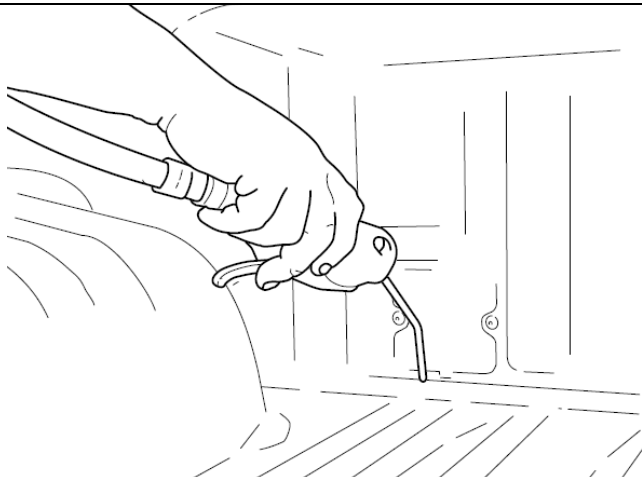

1.11) Using compressed air, completely blow out any metal filings / swarf in the tray floor.

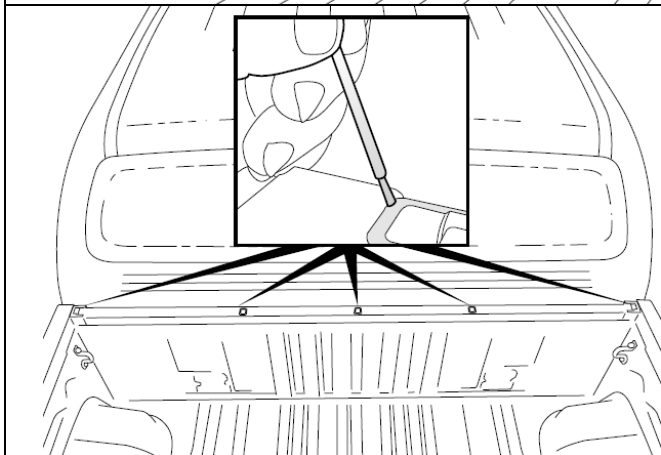

1.12) After removal, touch up the bare metal with primer,

SECTION 2: FITTING THE TAILGATE DOOR SEALING TUB STOP ASSEMBLY

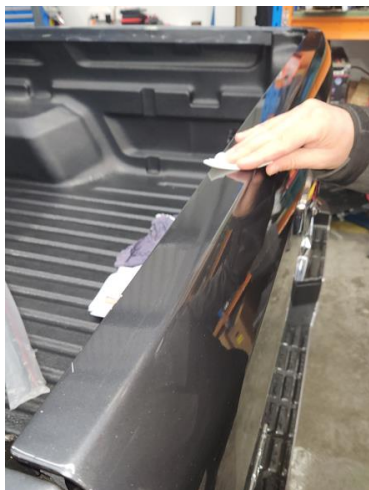

2.0) Clean the vehicle's tailgate top edge using an alcohol wipe (6602018).



2.1) Test fit the rubber door sealing tub stop assembly (667AQ001) with the curved overall profile of it facing towards the rear of the vehicle, to the top of the tailgate, aligning the inner ends to the inner ends of the tailgate and apply masking tape along the outer edge of it and then remove the door sealing tub stop assembly.





2.2) Apply primer (665044) by squeezing the primer stick until the tip is damp. At a 5mm offset to the tape edge, apply primer in a 15mm wide area across the tailgate where the rubber door sealing tub stop assembly is to be positioned and let it dry.



2.4) Remove 50mm of the red double-sided tape liner at the back side of each end of rubber door sealing tub stop assembly and relocate the assembly to the tailgate with the outer edge realigned to the edge of the masking tape. Press the ends down to adhere.

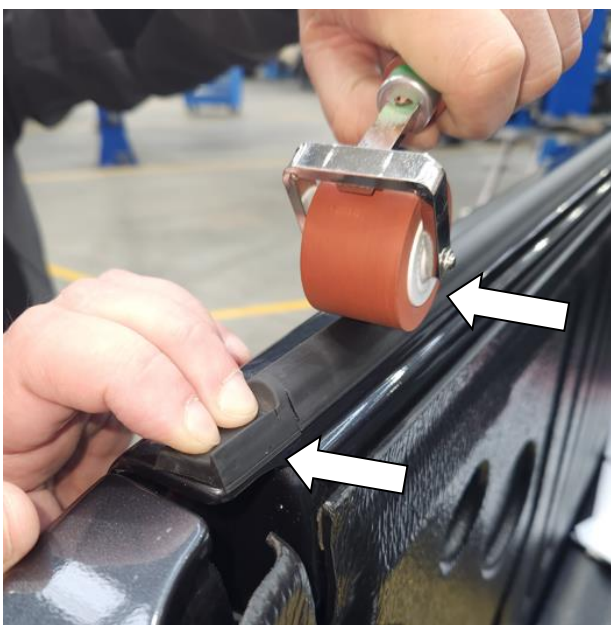

2.5) Apply firm pressure at each end of rubber door sealing tub stop assembly (667AQ001) to the tailgate and pull out the remaining tape liner backing paper. **Apply firm pressure all the way along the rubber door tup stop assembly to ensure it has adhered to the tailgate.**

SECTION 3: SEALING THE FRONT CORNERS OF THE TUB, FRONT HEADER RAIL AND CANOPY MOUNTING BRACKET INSTALLATION.

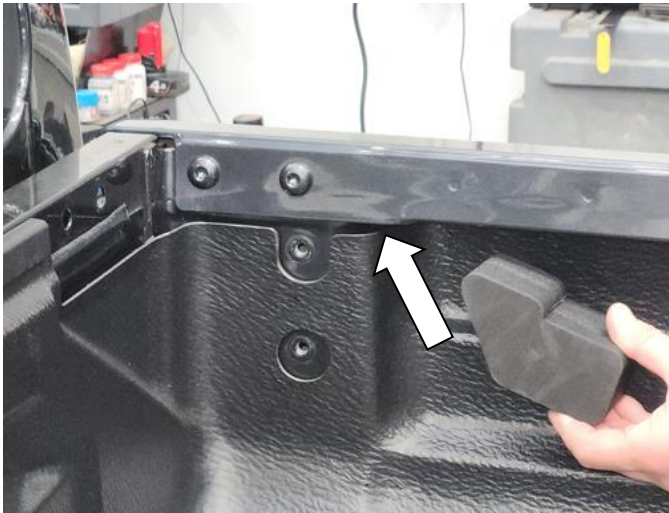

3.0) Take one from the pair of (669PB005) foam front tub corner sealing blocks. With the angled face facing forward push this up into the front corner of the tub under the inner rail lip of the tub. Seat it on the sheet metal edges of the hole. Repeat this for the other side of the tub.

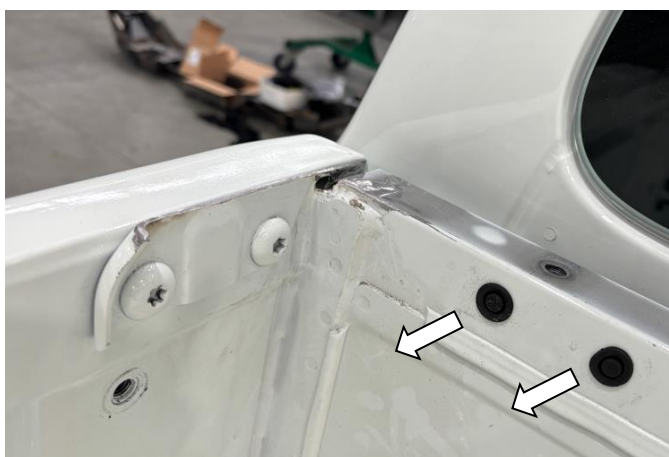

3.1) At the front corner of the tub remove the rubber grommets in the corners and discard them.

!! IMPORTANT !!

If fitting to a vehicle that has had the OE Roll top tonneau cover and sailplane removed, weld nuts will be instead present in this location. Use fitting kit 6178553 and refer to its instructions (37800359) for corner bracket mounting and resume following these fitting instructions afterwards.



3.2) **!! IMPORTANT !!**
If fitting to a vehicle that has had the OE Roll top tonneau cover and sailplane removed, use the contents of the additional kit 6178553 and brackets 669AQ042R/L. Refer to the fitting instructions in this kit (37800359) for this step and the next step.

If NOT fitting to a vehicle that has had the OE roll top and sailplane removed, fit between the cabin and the tub place in nut plate (669AQ041) to align to the holes where the rubber grommets were removed. The end of the nut plate may be bent to a shape to provide access for fitment. Place masking tape on the back of the cabin before it is inserted to prevent scratching the cabin's paint work.

Break off after fitting

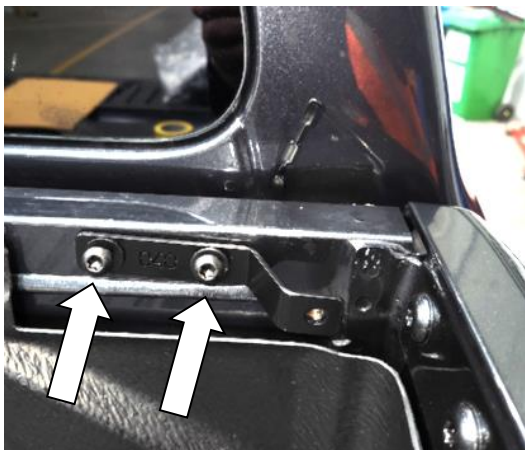
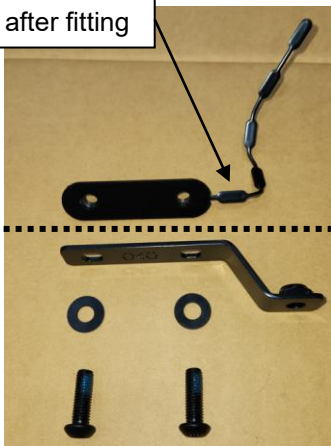

3.3) Loosely bolt up the header rail support bracket (669AQ040) using two M8 x 19 OD x 2mm thick flat washers (4584393) and two M8 x 25 Torx button head screws (6151625) through into the nut plate (669AQ041) on the other side of the tub. Tighten, but allow brackets to still be slightly loose in position. The picture shows the arrangement for the right-hand front corner of the tub.

Once assembled, brake off the bend tag from the nut plate by bending it several times until it breaks off.



- 3.4) Clean the front head board top face of the tub using an alcohol wipe (6602018). Prime the top face of front head board on the tub using the primer stick (665044). Remove the red double sided tape liner on the back of the front header rail assembly (664255).

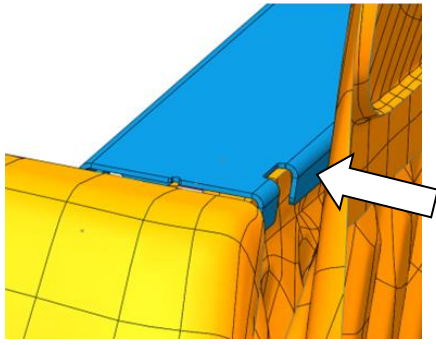

3.5) Place the front header rail assembly (664255) down onto the front head board face by hooking it over the front of the tub and place it centrally between each inner side wall of the tub, ensuring also the inner vertical face of the bracket engages the header rail support brackets (668AQ040) at each end.

Apply firm pressure all the way along the on the header rail assembly down onto the top of the tub to adhere the tape.

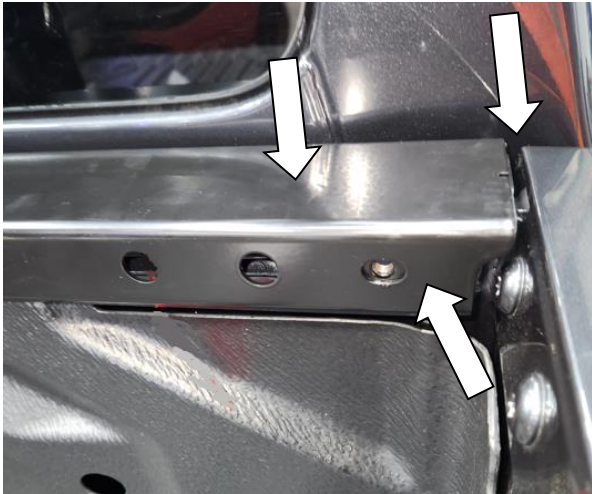

3.6) Remove the front tie down hooks in the front corners of the tub on both sides and give them to the customer with the bolts, or dispose of them.

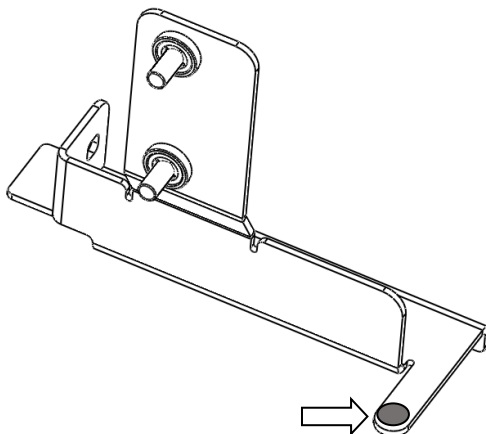

3.7) Fit a bump-on (665076) to the underside of the tag on a front corner mount bracket (669AQ035R shown).

Repeat for the opposite bracket hand.

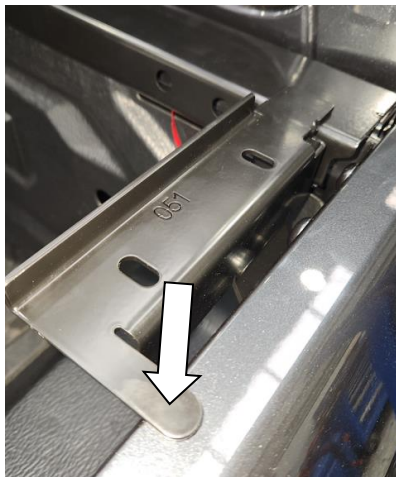
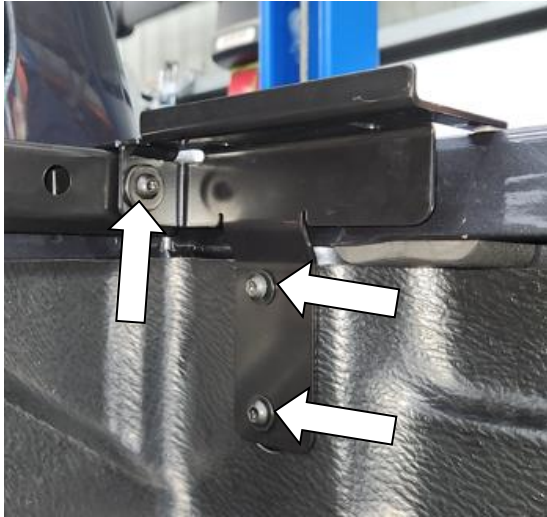

3.8) Loosely assemble the lower end of the front corner mount bracket (669AQ035R) to the holes from which the front tie down hook was removed. At the top front corner, assemble through the front corner mount bracket an M8 x 25 Torx button head screw (6151625) with a M8 x 25.4 OD x 3mm flat washer (4581303) through the header rail assembly into the nut plate.

Tighten the M8 Torx bolt loosely in between the front corner mount bracket and the front header rail assembly into the nut plate, while keeping the front corner mount bracket rear leg with bump on it, engaged down onto the top face of the side of the tub.

Repeat on the opposite side of the tub using bracket 669AQ035L.

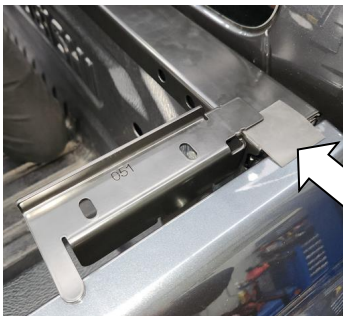

This side to outside of tub sides

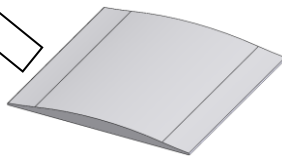

3.9) Clean the rea with an alcohol wipe and apply to the right-hand top end of the front header rail assembly, the bridge seal (668PM005), by removing the backing paper off the adhesive side. Slide it under the tag of the front corner mounting bracket and stick it down to the dimensions shown opposite.

The ramp curved profile should go between the front header rail and the side of the tub as a “bridge”.

!! IMPORTANT !!

POSITION THE SEAL BRIDGE EXACTLY AS SHOWN OR FRONT CORNER WATER LEAKS COULD OCCUR

Repeat on the opposite end of the front header rail.

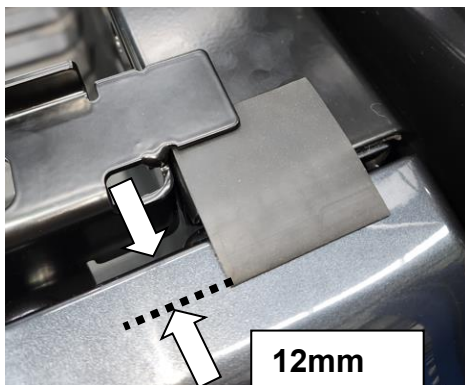

12mm

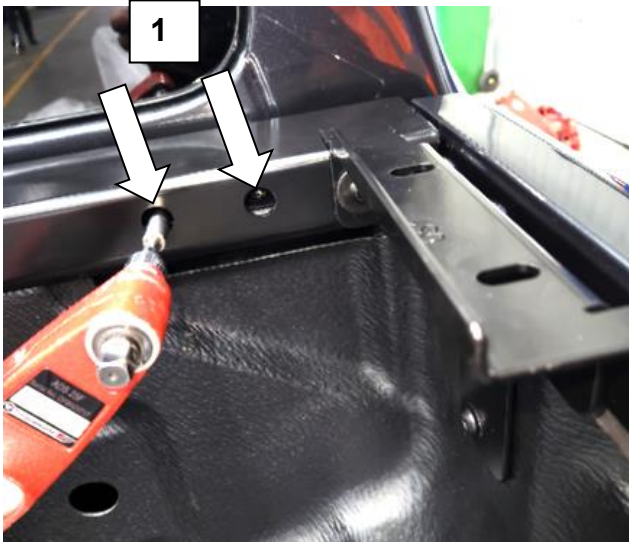

3.10) Through the holes in the front header rail tighten the T40 screws **to 20Nm torque** on the (668AQ041) front hear rail support brackets.

Then tighten the front corner mounting bracket's lower mounting screws **to 20Nm torque ensuring the tag on the rear end of the front corner mount brackets engages the top of the tub.**

Then tighten the front corner mount bracket bolts to the header assembly **to 20Nm Torque.**

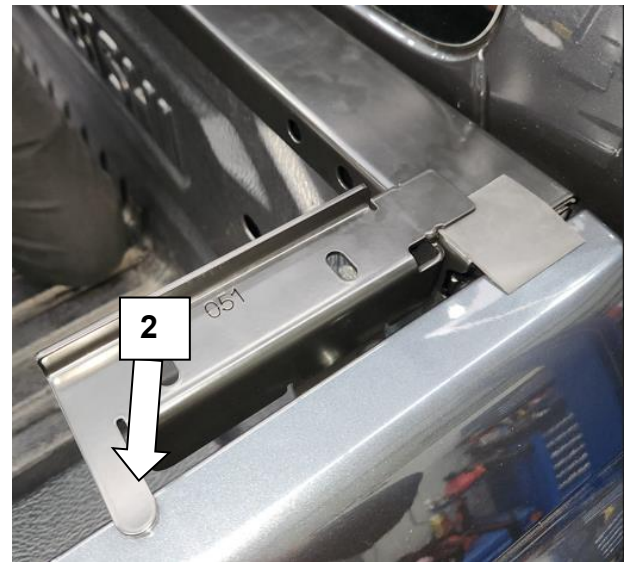
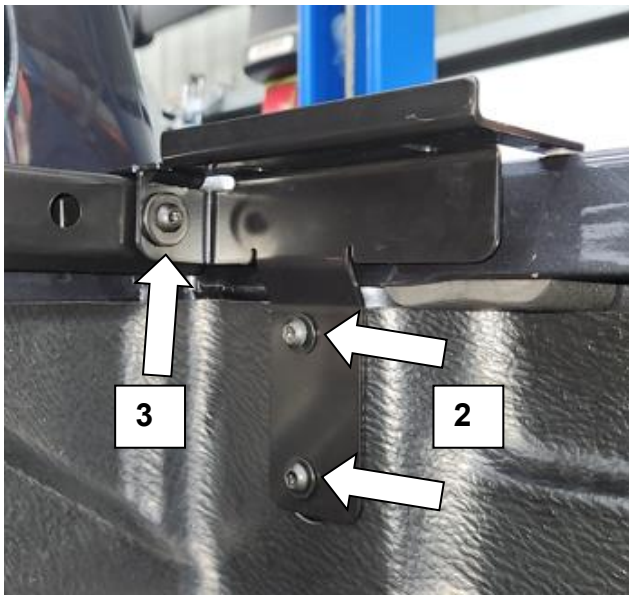

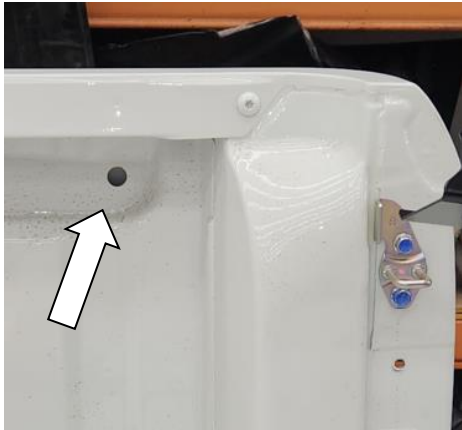

3.12) If no bedliner is fitted, apply black stickers (668PB006) on each side of the tub to the holes in the inner wall of the tub at forward and aft each side.

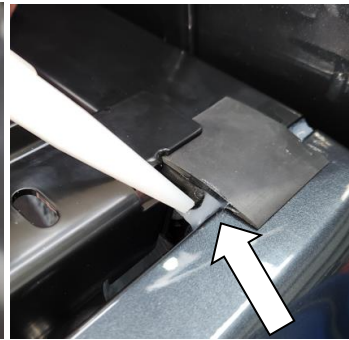

3.13) Apply (neutral cure non-acetic) silicon to the join between the front head rail to tub sides from underneath the bridge seal in the rear corner and at the front and the back side, to stop water leaks.

The bridge seal provides a transition from the front tub mount rail to the top of the side tub walls to provide a sealing surface to the bed seal that is fitted between the canopy and the tub in later step.

APPLY SILICON AS SHOWN OR FRONT CORNER WATER LEAKS COULD OCCUR

Carefully, clean off excess with a rag applied sparingly with silicon remover, or wax and grease remove and make the joins neatly.

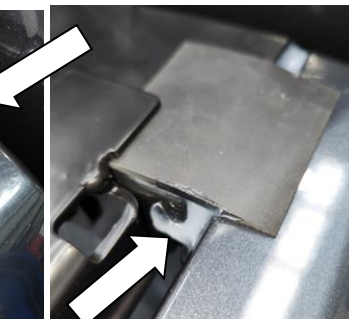

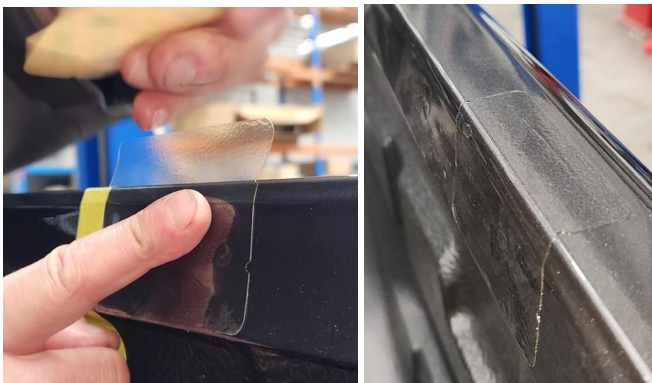
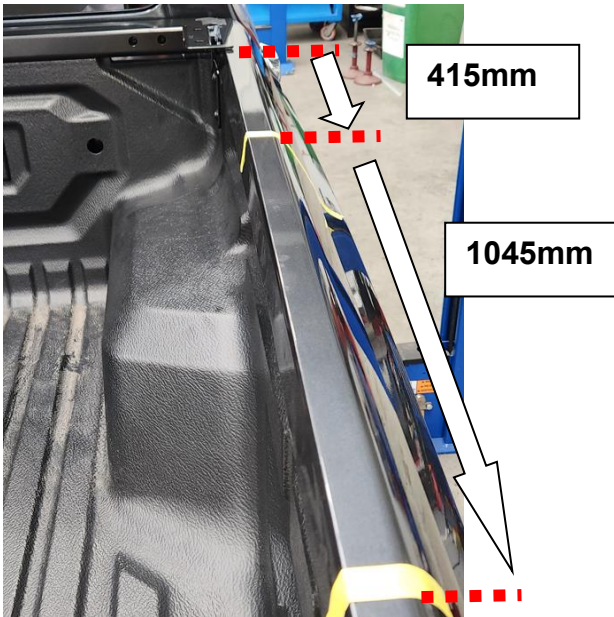
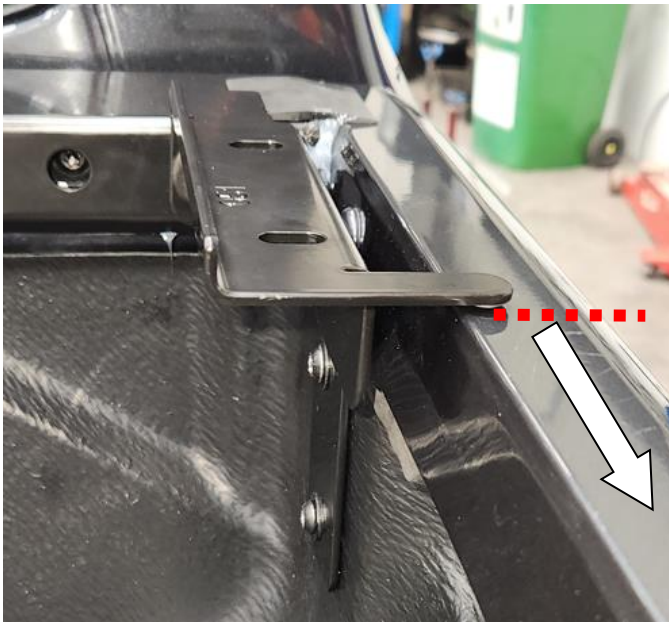

3.14) At the rear trailing edge of the front corner mount brackets on the top of the tub sides, measure back along the top of the tub and make **two marks at position at 415mm and at 1045mm on the side of the tub.** Apply four clear abrasion resistant pads (669PB004) (2 per side) at these positions **reward of the marks**, by aligning the 80mm long edge to the lower inner edge of the tub lip and the 64mm edge vertically, to the mark made on the tub and wrapping them up over onto the top of the tub rails.



3.15) Loosely preassemble the outer (669AQ037) and the inner tub mounting bracket clamps (669AQ036) using M8 x 40 Torx button head screws and M8 x 19OD x 2mm flat washer loosely.

Locate these over the centre of the clear abrasion resistant tape pads on the tub and do the Torx bolts up on each of the four clamp assemblies (2 per side of the tub) to 16Nm torque.

SECTION 4: FITTING THE TUB BED SEALS BEFORE THE CANOPY IS FITTED

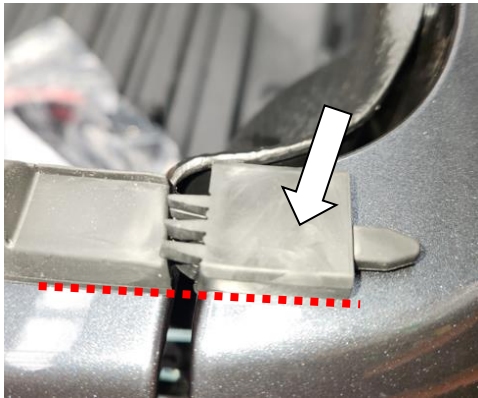
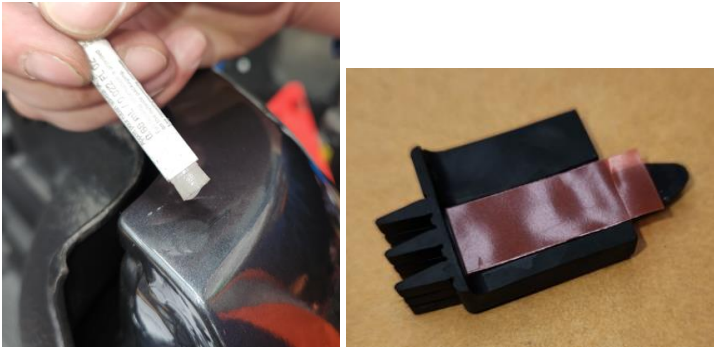
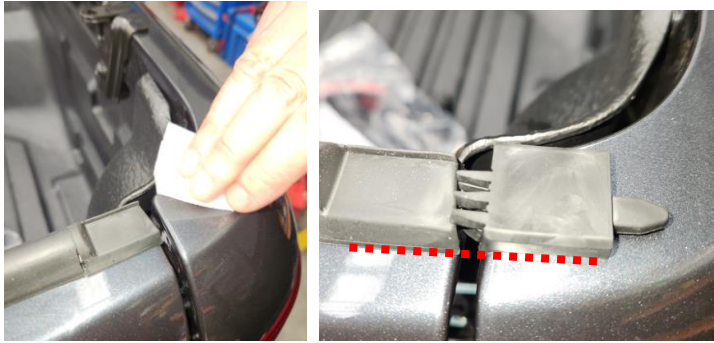

- 4.0) Clean the rear top faces of the rear corners of the tub adjacent to the tailgate with an alcohol wipe (6602018) and allow to dry. On the right hand side locate the right hand rubber side tub seal (667PE006R) and align its front edge with the front edge of the door sealing tub stop assembly. Note it's foot print and remove it. Apply primer (665044) to the area of the tub corner and allow it to dry to the by removing the backing paper off the double-sided tape on the underside of it and position it with the front leading edge face aligned to the end caps on the door sealing tub stop assembly on the tailgate.

Apply firm pressure to the part to adhere the tape.

Repeat on the other side of the tub using the left hand rubber side tub seal (667PE006L).



- 4.1) At the front corners of the tub, prime the area over the tub seal bridges (668PM005) using a primer stick (665044) (Break the vial at the dots by squeezing and wet out the felt tip to apply the primer).



THIS SIDE TO THE
OUTSIDE OF THE
VEHICLE



- 4.2) From the seal kit (6171422), clean the top of the vehicle's side tub rails down using alcohol wipes (6602018) out of the seal kit and allow to dry. Starting on the right-hand side at the rear tailgate end of the vehicle, slide the bed seal rubber extrusion (9009177) in the orientation shown, onto the spigot extending from the rubber side tub seal (667PE006R) ensuring the cut end is a neat tight fit between them. Remove the tape liner on the bed seal and curve it around the rear corner without puckering the seal and align the inner edge of the seal to the edge where the canopy mounting clamp assemblies (669AQ037) extends across the top face of the tub and continue to adhere the seal to the top of the tub so the inner edge contacts the rear finger on the front corner mount bracket.

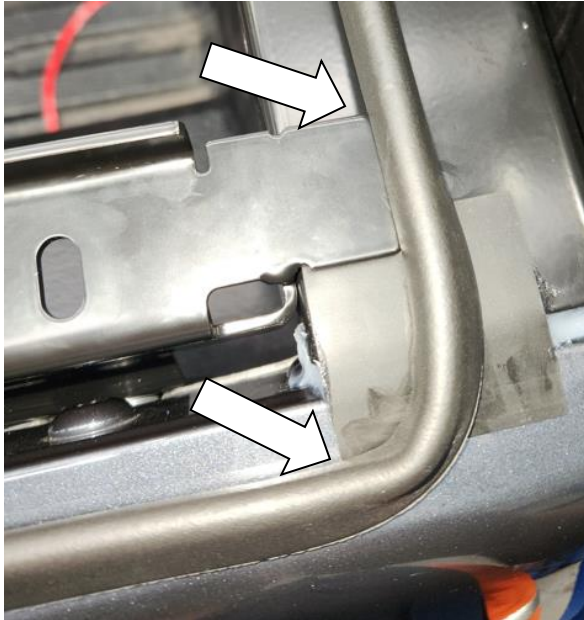

- 4.3) When applying the bed seal up at the front tub corner, ensure its inner edge is aligned to the outer edge of the tub seal bridge (668PM005). Curve the seal **without puckering** over the tub seal bridge aligning the inner edge to the leading front edge of the front corner mount bracket (669AQ035R).

Ensure the double-sided tape on the bed seal goes up the ramp of the tub bridge and is not stepped up across the corner of the tub bridge, which could cause water leaks.

Apply firm pressure to the seal over the tub bridge rubber extrusion.

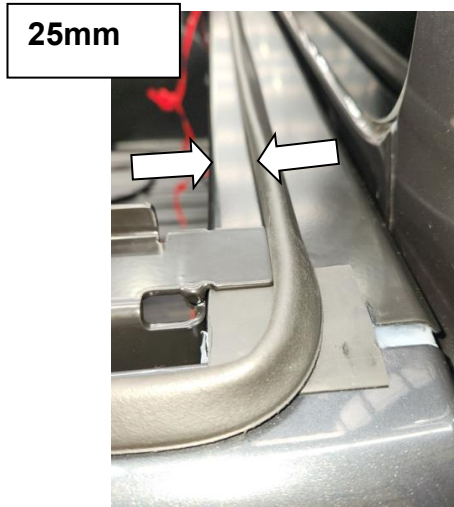

- 4.4) Apply the bed seal along the front header rail aligned at a 25mm offset between the inner edge of the seal and the inner edge of the header rail bracket.

Apply the seal with firm pressure to the front head rail using a printing roller.



- 4.5) Finish applying the seal to the left hand side of the tub following the same process as per the previous steps and trim the opposite end and slide it onto the spigot of the left hand rubber side tub sealing block (667PE006L) and make a neat cut join between them to avoid water leaks.

Apply firm pressure to the bed seal all the way around the tub to make the tape adhere.

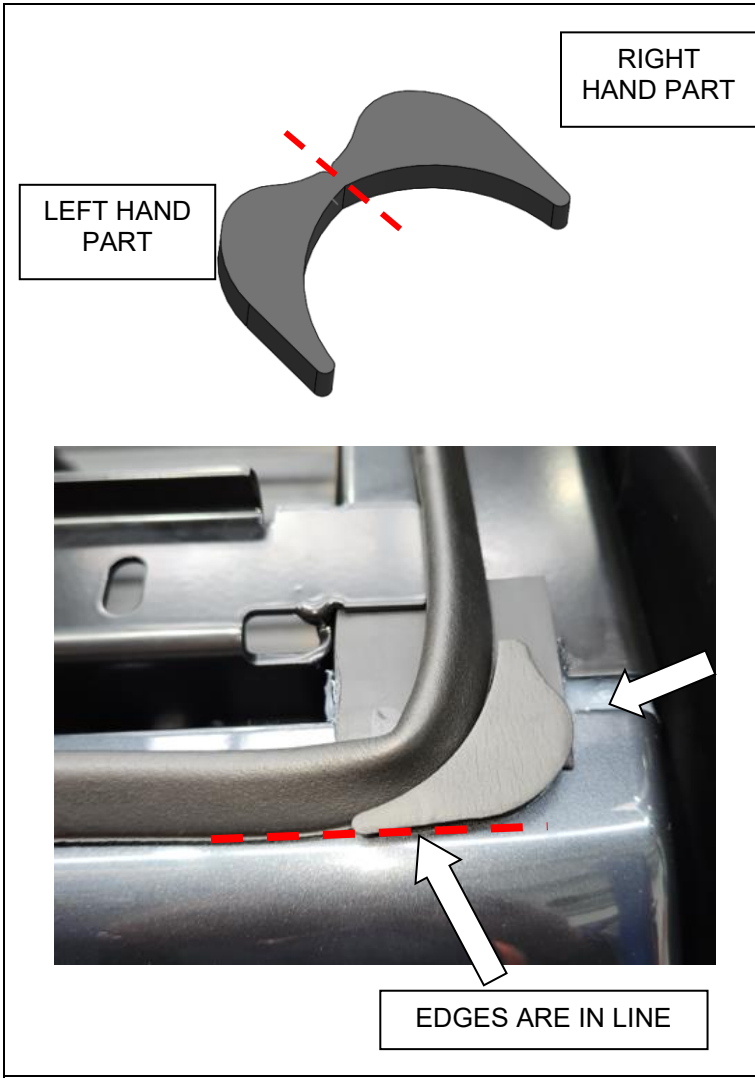

4.6) Split the pair of front corner foam seals (665082) and remove the backing paper and apply them to the front corners of the tub with the adhesive face down, so the outside edge of the foam pads are in line with the outside edge of the bulb seal (9009177) on each of the front corners of the tub.



4.7) Apply (neutral cure non-acetic) silicon to the inside edge of the bed seal for 150mm each way around the corner.

Carefully, clean off excess with a rag applied sparingly with silicon remover, or wax and grease remover.

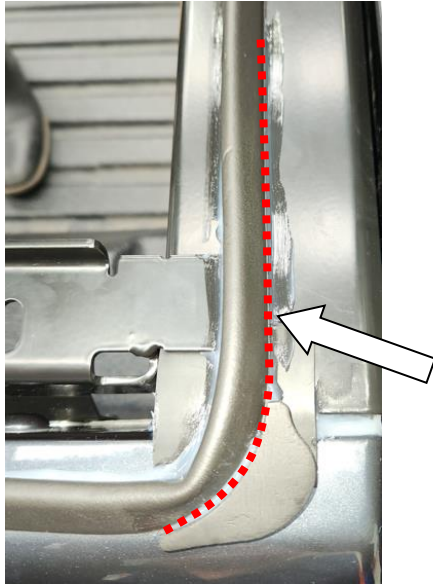

- 4.8) Apply (neutral cure non-acetic) silicon to the outside of the bulb seal between the front corner foam seals (665082) and the bulb seal and also 150mm across the front header rail on both sides of the tub.

Carefully, clean off excess with a rag applied sparingly with silicon remover, or wax and grease remover.

SECTION 5: FITTING THE CANOPY

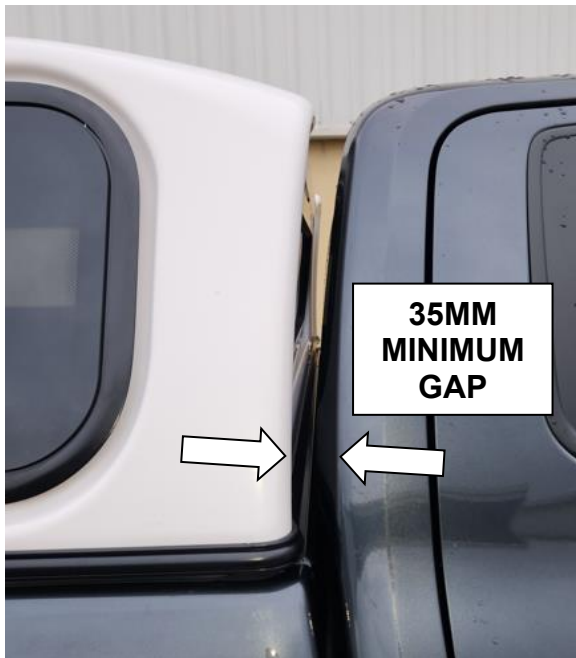

- 5.0) Close the vehicle's tailgate. **Lift the canopy onto the vehicle with 2 people.** Avoid dragging the canopy on the seals mounted on the tub as this could dislodge them and disturb silicon sealing on the front corners of the tub. Lift and place the canopy down onto the vehicle's tub. **Ensure it is aligned across the width centrally to the vehicle at front and back.**

Check minimum gap from canopy front pillars and cabin is 35mm. (Use a socket at diameter 35mm OD to check this).



- 5.1) Centre the canopy across the tailgate by aligning the end caps on the door frame to the lower edges of the vehicle's tub adjacent to the tailgate. Ensure the gap between the door glass and the door frame is even, and between 3.5 and 7mm.

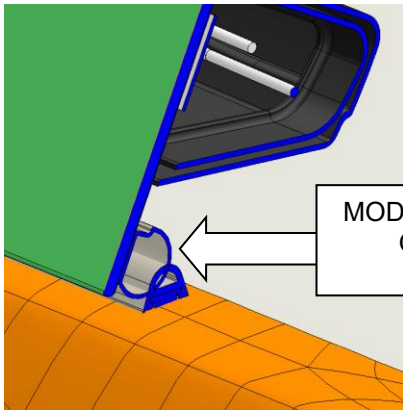

MODERATE COMPRESSION
ON DOOR SEAL TO
TAILGATE STOP

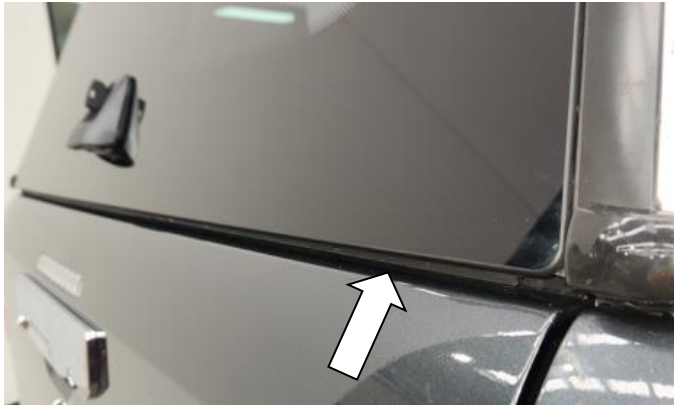

- 5.2) With the door closed, check the pressure on the lower glass door seal to the tailgate door sealing stop assembly is moderately compressed, but not fully compressed to provide a seal on the lower edge of the door.

Ensure the door can close and latch without excessive force.



- 5.3) With the canopy centred and door gaps even to the glass, locate the sideways slotted hole in the rear corners of the base inside the canopy. Place an M8 x 25 Torx button head screw (6151625) with M8x25.4x3mm thick flat washer (4581303) in through the slot in the canopy's base rail and the canopy clamping bracket on the tub. On the underside assemble an M8 x 19 OD x 2mm thick flat washers (4584393) and a M8 nyloc nut (6151212)

Repeat on opposite side of the canopy.



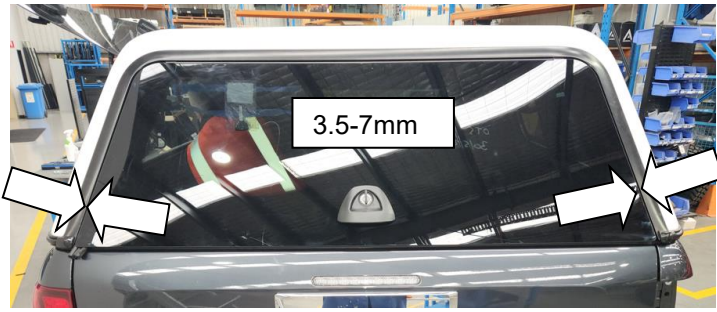

5.4) Ensure the gap between the door glass and the door frame is even, and between 3.5 and 7mm.

Tighten the M8 bolts between the canopy to the tub mounting clamping brackets to 20Nm.



5.5) **!!IMPORTANT!! Ensure the gap between the lower door glass edges to the top of the tailgate is greater than 8mm (nominally it should be 10mm) and even left to right. If it is not, the canopy will need to be packed up with washers at the bolting points between the base rail and the rear most mounting clamps to the tub until minimum of 8mm is achieved and without loss of sealing of the canopy to the bed seal down the sided of the tub.**



5.6) At the front interior corners of the canopy locate the forward/aft slotted holes in the base rail. Place two M8 x 25 Torx button head screws (6151625) with M8 x 25.4 x 3mm thick flat washers (4581303) in through the slot in the canopy's base rail and the front tub corner mounting bracket. On the underside assemble an M8 x 19 OD x 2mm thick flat washers (4584393) and a M8 nyloc nut (6151212)

Repeat on opposite side of the canopy.



Tighten the M8 bolts between the canopy to the front tub corner mounting brackets to 20Nm.



- 5.7) At the mid-point interior of the canopy locate the cross-wise slotted hole in the base rail. Place an M8 x 25 Torx button head screw (6151625) with M8x25.4x3mm thick flat washer (4581303) in through the slot and the canopy clamping bracket. On the underside assemble an M8 x 19 OD x 2mm thick flat washer (4584393) and a M8 nyloc nut (6151212).

Repeat on opposite side of the canopy.

Tighten the M8 bolts between the canopy to the tub mounting clamping brackets to 20Nm.



- 5.8) Close the vehicle's tailgate up to the edge gutter seals on the door frame. Mark a line across the seals where the ends of the tailgate door sealing tub stop rests against the door seals. **Measure 5mm down from this and cut the door frame seals horizontally, very neatly, with sharp scissors. Once cut, the ends of the door frame seals should just touch the recessed face of the top of the door sealing tub stop assembly (667AQ001) at each end of the tailgate.** Tune the cut ends of the door frame seals so the door seals just miss the top of the tailgate when it is opened so these do not foul and crush on the inside of the tailgate when it is closed.



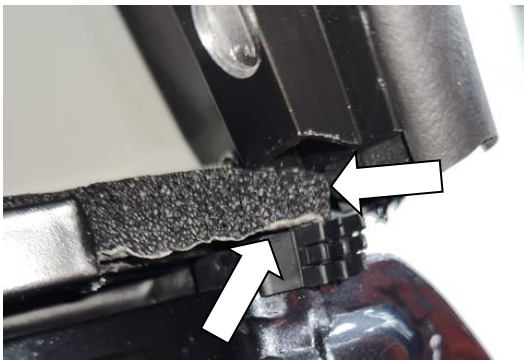
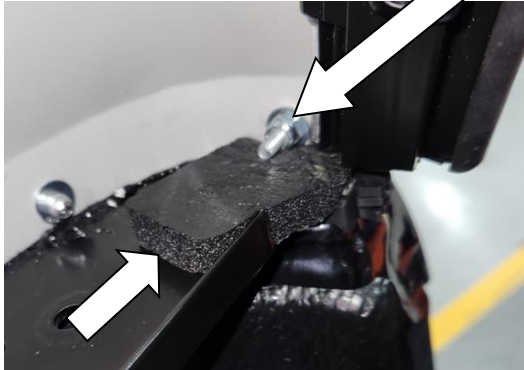
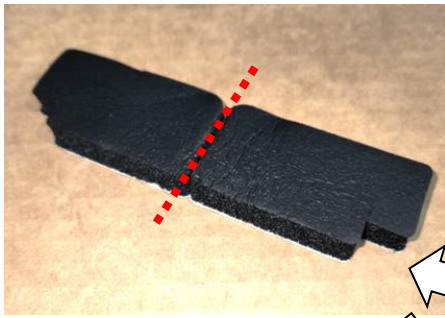

5.9) Separate the foam tape pads (665083). Position them in the rear corners of the canopy on the canopy's base rail (Right hand rear corner shown) **so the notch is under the stud protruding from the inner rear corner of the canopy. Ensure the foam pads are placed to align over the top the side tub seal (667PE006R) and align it to its edge and to the rear to touch the back of the door frame seals and door frame at the rear inner corner.**

Repeat on the opposite side of the tub.

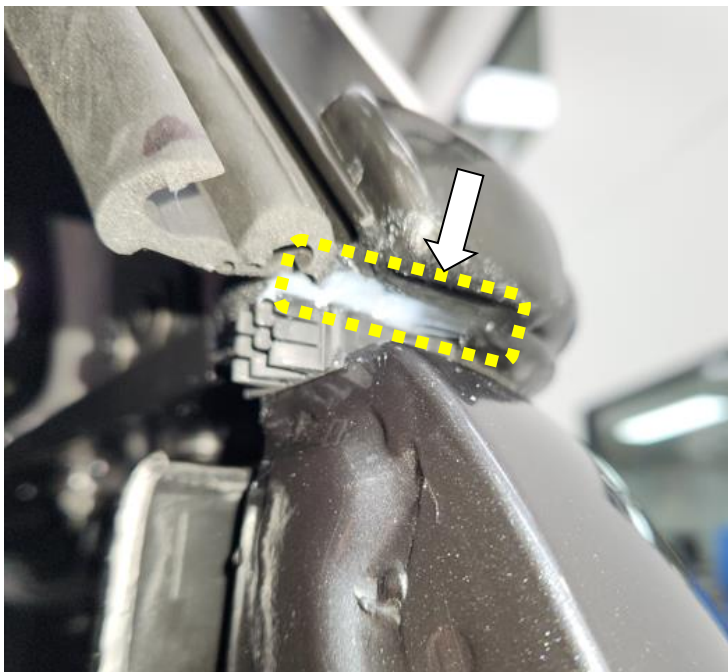

5.10) With the tailgate down and door open, apply neutral cure silicon up into the rear corner tailgate sealing areas, between the door frame and its lower end cap, canopy base rail and the sealing face of the tailgate sealing foam pad and side rubber tub seals.

Clean up excess and smooth the silicon down and ensure on the inside of the canopy's rear corner the area is sealed.

SECTION 6: WIRING THE CANOPY

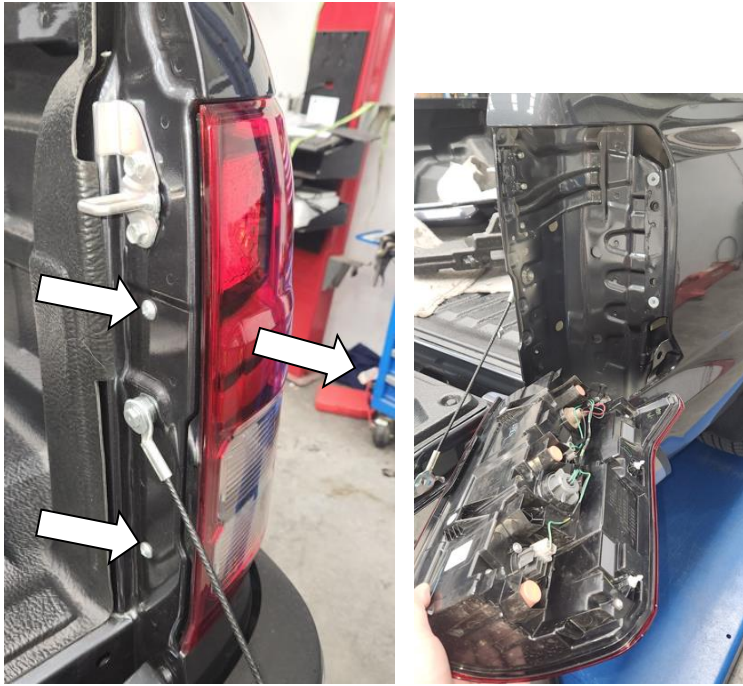

6.0) Remove the rear tail light assembly on the right hand side. Do this by first undoing the 2 screws in the tailgate opening. Then pull the light to rear.

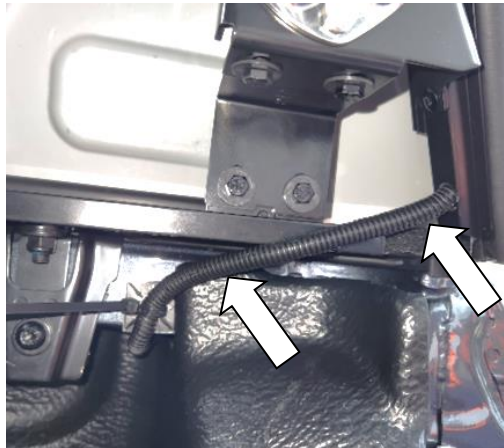

6.1) Cover the wiring loom that is coming out of the lower right-hand corner of the door with split convoluted tube (6821135). Route the loom from the door up under the rear right-hand corner of the tub into the right hand tail light cavity.

Apply a cable tie base (6821293) to the wall of the tub and zip tie the loom to the cable tie base using (180302).

Ensure the door loom reaches down to the middle height of the tail light recess in the tub.



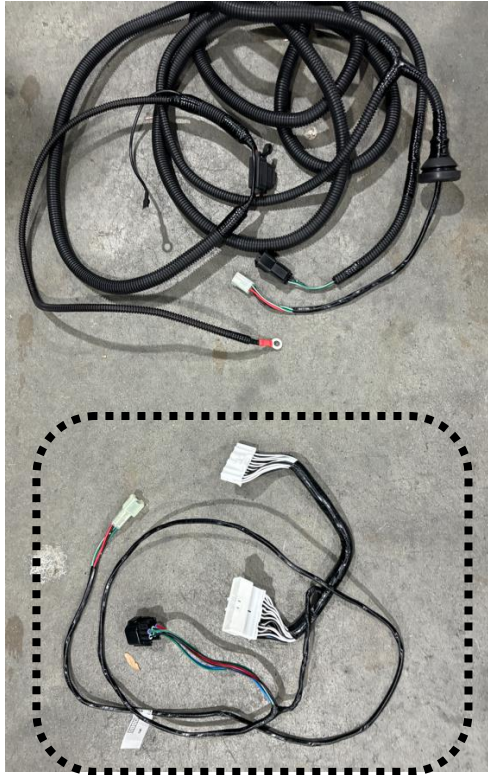

6.2) Unpack (669PJ025) vehicle patch loom from the fitting kit. Take the shorter loom.

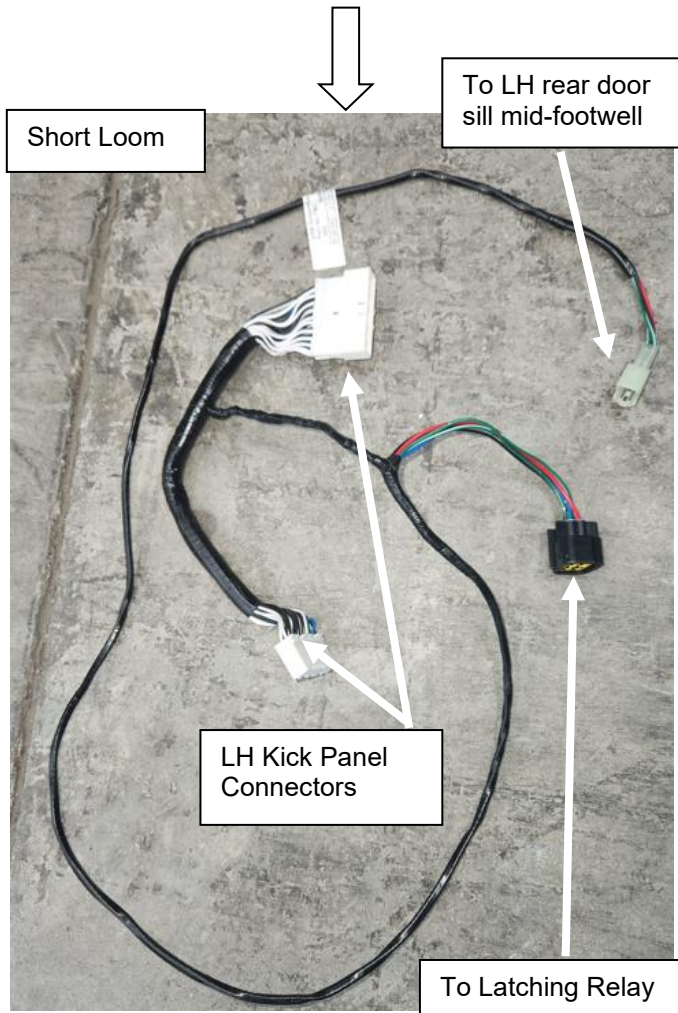



6.3) Open the front left hand door on the vehicle, and locate the lower kick panel cover. Remove the door sill scuff plate and the kick panel cover. The kick panel cover has a screw at the top front corner that must be undone to allow removal.



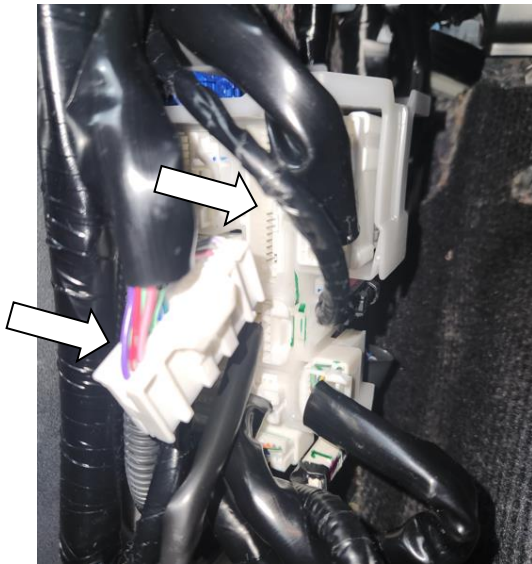

6.4) Locate the 40 pin large flat connector on the vehicle in the **uppermost MIDDLE** kick panel area, disconnect it and patch in the connectors from the shorter harness (669PJ025) and connect this between the 2 connectors on the vehicle. **Note if the canopy wiring does not operate correctly please check you have plugged into the correct location.**



6.5) Use (668PB015) anti-rattle foam strips and apply in the two positions shown wrapped around (668PJ015) latch relay.

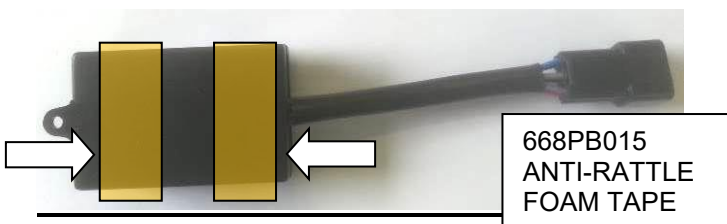

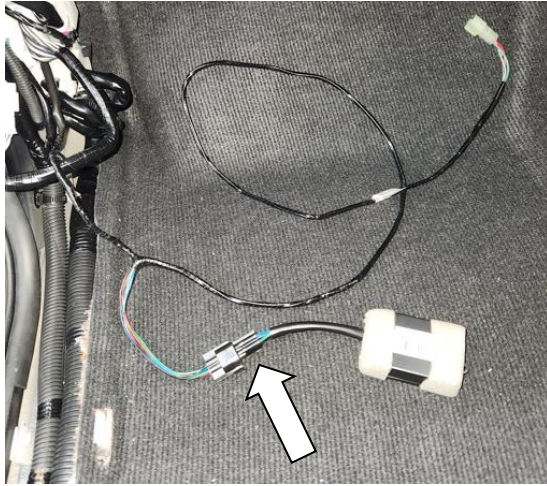

6.6) Connect the latch relay to the 6 pin connector on the canopy patch harness at the lower kick panel.



6.7) Position this on top of the vehicle's connector housing block and cable tie it through the loop on the relay box to the vehicle's wiring loom to secure it.



6.8) Reinstall the lower kick panel cover while running the loom rewards along the door sill edge near the edge of the floor carpet.



6.9) Remove the rear left hand door lower scuff plate. Pull away the lower "B" pillar trim next to the front seat at the base by removing the 2 piece cover.



6.10) Run the loom to the mid position of the rear door foot well area, next to the floor carpet edge.



6.11) Under the car and while on a vehicle hoist, find the rubber floor grommet next to the left hand chassis rail and remove it in the floor pan in the rear left hand seat area. Using the main larger loom from the hardware kit (669PJ025), feed the 4 pin connector with rubber grommet end up into the hole and seat the grommet into the hole. The 4 pin male connector, is then to be run under the floor carpet across to be connected to the smaller canopy patch harness at the 4 pin female connector near the edge of the carpet at the rear door sill.

Reinstall the "B" pillar trim and all the lower door scuff plates.



6.12) Under the vehicle, run the canopy patch harness with the 4 pin connector rearward along the left hand chassis rail following the vehicle's wiring path rearward/

Cable tie the loom to the vehicle's loom above the chassis rail every 200mm and avoid tying to brake lines, moving parts, sharp parts and away from hot exhaust systems.

Per the image shown, cable tie off the canopy patch harness near the left hand rear corner of the chassis rail to the vehicle's loom.

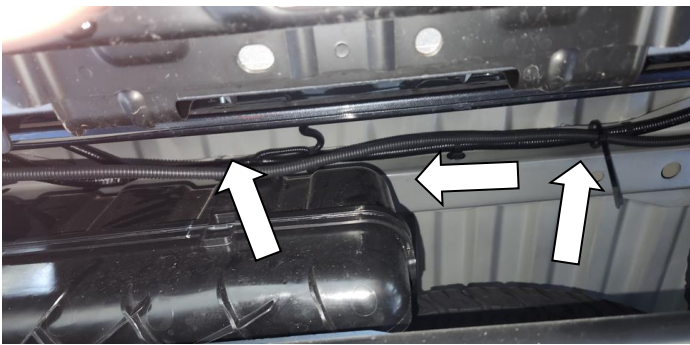

6.13) Cross the loom across the car following the vehicle's rear tub floor cross member following the vehicle's wiring loom, to the right hand side

Cable tie the loom to the vehicle's loom every 200mm and avoid tying to brake lines, moving parts, sharp parts and away from hot exhaust systems.



6.14) At the lower area under the right hand rear tail lamp, cable tie the canopy harness to the vehicle's harness and run it up into the tail lamp recess

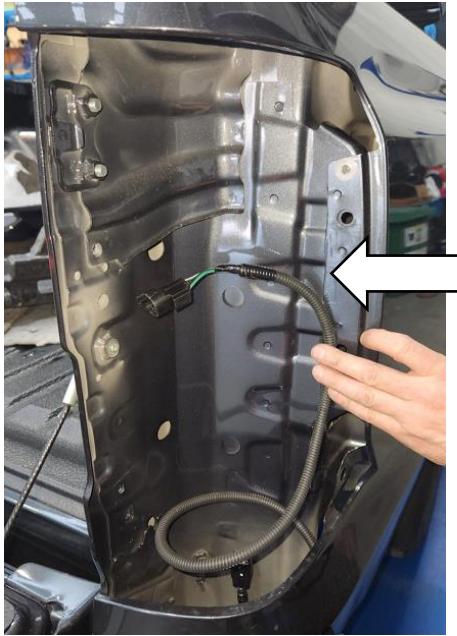

6.15) Run the 4 pin connector of the canopy patch harness up into the right hand tail light recess. Ensure there is enough length to reach the wiring coming from the canopy door.

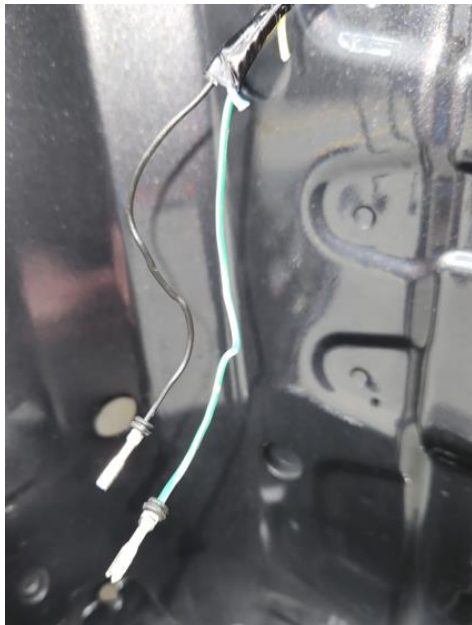

6.16) Take **the male connector** from the patch loom kit (669PJ025) and push the two seal grommets with the bosses onto each of the **2 wires coming from the canopy door loom onto the Black and Green/White wires (Ignore Blue and Yellow and cut them back)**. The grommets should have the shanked ends towards the cut end of the wires. Strip the wires to 12mm to bare them, fold them to double over and twist the ends and make each bare stripped wire 6mm in length. Crimp on the female terminals to the wires and at the ends around the grommet shanks

IMPORTANT - insert the wire terminals into the male connector to clip in. **ENSURE wires are positioned in the connector to match the colours in the corresponding female connector for the canopy patch loom.**



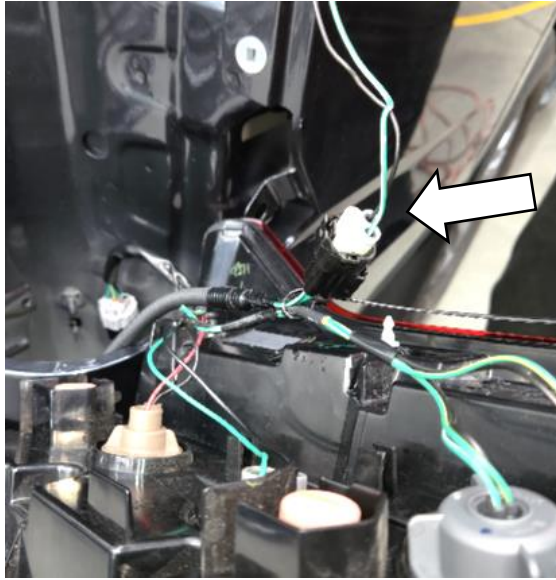

6.17) With the connection made between the canopy patch harness (666011) and the door loom at the connectors, cable tie this to the wiring at the mid position of the back of the tail lamp to ensure the connection is secured to the vehicle.

Refit the right-hand tail lamp.



6.18) Back under the vehicle on a hoist, under the left hand floor pan at the canopy harness branch, run the end of the (669PJ025) wiring loom with the eye terminals forward along the chassis rail.

Cable tie the loom to the loom on the chassis rail every 200mm and avoid tying to brake lines, moving parts, sharp parts and away from hot exhaust systems.

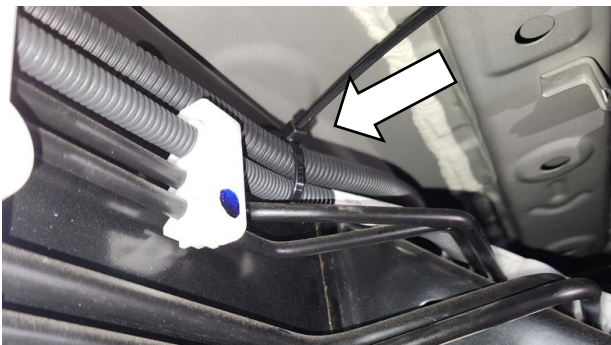

6.19) At the front left hand wheel well, cable tie the loom to the mounting bracket for the trim clip retainer. Then feed the loom up into the engine bay.

Cable tie the loom to the loom on the chassis rail every 200mm and avoid tying to brake lines, moving parts, sharp parts and away from hot exhaust systems.

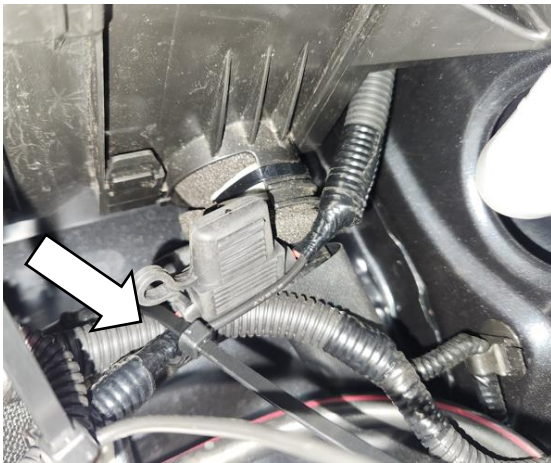
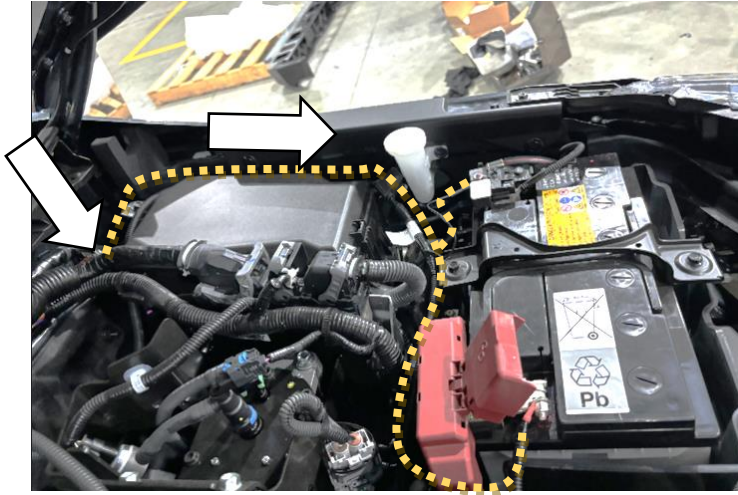

6.20) Open the bonnet and run the loom up against the firewall and around the back left-hand corner of the engine bay. Run the loom along under the area of the fuse box next to left hand fender towards the battery.

Cable tie the loom to the loom in the left hand rear corner of the engine bay **and avoid tying to brake lines, moving parts, sharp parts and away from hot exhaust systems.**

Route the harness around the back of the fuse box next to the left hand fender

Locate the positive battery terminal. Connect the eyelet on the red wire from the canopy loom to the terminal. Connect the eye terminal on the black wire to the battery negative terminal.

Cable tie the loom neatly in place around the engine bay and cable tie the fuse holder on the canopy loom down the vehicle's wiring behind the battery.

SECTION 7: OPERATIONAL CHECKS

Canopy and wiring fitment is now complete. Operational checks need to be undertaken as follows.



7.0) Check the interior light works when turned on and off.



7.1) **Press unlock TWICE on the vehicle key- first.**

7.2) Press the rear door rubber touch pad to open the rear door.

7.3) Press lock on the vehicle key

7.4) Press the rear door rubber touch pad. When locked, the door should not open.



7.5) Remove the keys from the window struts and rear door struts. **2 window keys and 1 door key** should be added to the customer's key ring. **Check the keys work manually in all locks.**

7.6) Place all remaining keys in the customer's glove box on a cable tie

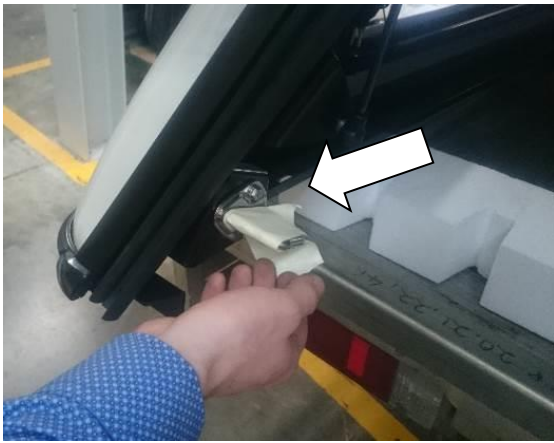

7.7) Place masking tape around the stainless-steel striker loop and slam the door shut 3 times.

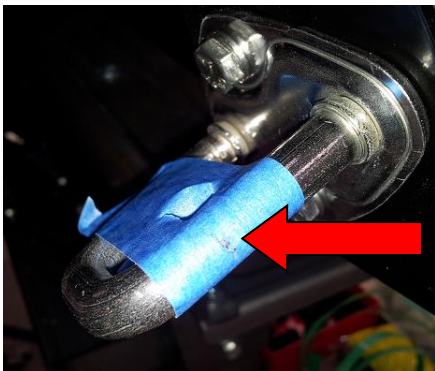

- 7.8) **Check there is only wear on face that is rearwards from the vehicle.**
- 7.9) If there is wear on top or underneath on the striker loop, loosen the bolts on the striker loops and adjust the position of the loop up or down
- 7.10) Tighten and retest with tape again until the desired latch wear point is obtained. Once satisfied, tighten the striker loop bolts to **9Nm, using a torque wrench**



7.11) With the door open, engage both latches, then **SLOWLY** twist the yellow release handle and listen to hear if both latches open at **EXACTLY** the same time.



7.12) If the latches don't release at the same time, remove the 6 screws holding the centre cover, remove the centre cover to get access to the latch rods.



- 7.13) On the side which released last, remove the rod clip and pull the pull rod out. Rotate 1 turn to shorten it.
- 7.14) Reinstall the rods into the clips, **CLIP THE ROD END SHUT.**
- 7.15) Retest the latches by operating the interior handle to check they work simultaneously.
- 7.16) When satisfied, replace the covers, **CHECK ALL 6 SCRIVETS ARE REINSTALLED.**



- 7.17) **Shut the door as gently as possible for a latch to engage.** Check that both latches engage at **EXACTLY** the same time.



- 7.18) If the latches don't engage at exactly the same time, loosen the 2 stainless steel M6 screws and tap the latch striker forward 1-2mm.
- 7.19) Retighten the M6 bolts to **9Nm using a torque wrench**, retest the door during closing to check.



SECTION 8: OWNERS MANUAL SUPPLEMENT (Fill in and give to customer).

ARB – XCLS18 Mitsubishi Triton 24+ or XCLS19 Nissan Navara 26+ DC Classic Plus Canopy

WINDOW KEY CODE (Write it in boxes opposite)	<input type="text"/>	<input type="text"/>	<input type="text"/>	<input type="text"/>	<input type="text"/>
DOOR KEY CODE (Write it in boxes opposite)	<input type="text"/>	<input type="text"/>	<input type="text"/>	<input type="text"/>	<input type="text"/>

Warranty

- Refer to ARB Products “Warranty Against Defects” booklet contained within the hardware kit, to be delivered to the customer upon purchase.
- ARB provides a 3 year warranty with this product from date of purchase via the original purchaser.
- One year warranty is provided on gas struts.
- This warranty does not cover modifications / alterations, improper installation, use of non-genuine ARB accessories, abuse / misuse, accident, lack of maintenance, normal wear and tear and exposure to chemicals or solvents harmful to plastics.
- Loss of contents within the tub and canopy due to use, breakage during theft, leaving the canopy unlocked, lack of maintenance or miss-use of the product is the responsibility of the vehicle operator.
- Normal wear and tear from the vehicle’s operation with the canopy can occur and paint rub result on the canopy or the tub over time. It is recommended that the customer observes wear on tailgate protection tape and periodically replaces it.

Safety Warnings

- The canopy will only unlock on the remote key fob when the unlock button is pressed.
- Do not drive with windows or doors open other than the sliding windows. All doors and lift up windows should remain closed and latched.
- Do not sit, rest or stand on the canopy roof, or rest heavy objects on the roof without these being loaded on ARB genuine roof bars or racks systems.
- Do not fit any roof bar or roof rack system other than ARB genuine accessories designed for this canopy.
- Do not use the vehicle’s tub with a canopy fitted as a passenger compartment.
- Do not transport or store volatile materials such as solvents, chemicals or liquids, as fumes may cause damage inside the canopy, or cause fire, due to reduced ventilation.
- Do not fill fuel containers inside the canopy as static electricity can build up causing a fire.
- Do not allow solvents, chemicals or oils to contact the canopy as damage can occur. Clean interior canopy surfaces with water and mild detergent.
- Do not depress the rear door push button switch for a period of time other than to function their operation. Neglecting this may cause overload. Overload switches on locking systems should reset after 30 seconds.

Maintenance Requirements

- At routine vehicle service schedules, screw torques as described in this fitting instruction should be checked. (Please ask the company that fitted your canopy for a copy of the fitting instructions).
- At routine vehicle service schedules, or as conditions dictate, lubricate the handle lock with Teflon spray e.g. SuperLube multipurpose Aerosol or 3-in-1 Professional Lock Lubricant or Isoflex Topas L32 grease. Latches and hinges may be serviced with Isoflex Topas L32 grease. Molybond 122 can be used on hinges. Do NOT use any other greases, oils or aerosols as failure may result voiding warranty.
- Ensure functional checks of the rear door, lift up windows, and brake light are carried out at vehicle service schedules.
- To clean, only use quality car care mild detergents, waxes and polishes. Do not use abrasive compounds on painted surfaces unless conducting repairs. If paint repairs are undertaken only bake at 60oC. Use only paint systems that are suitable for ABS plastic.
- Ensure gas struts are only ever connected with the cylinder end to the glass and the rod end to the canopy’s window frames. Failure to do so will cause premature failure of gas struts.
- Clean gas strut rods with a damp cloth only when regularly cleaning the vehicle. Seal failure of the strut can occur if cleaned with solvents or greased or left uncleaned.

Water Intrusion

- Under rain and thunderstorms even during driving conditions, the canopy should only leak through unsealed tailgate areas at the sides of the tailgate.
- Under the presence of high pressure washing or automated laser car washes, water may leak into the vehicle’s tub over the top of the canopy’s rear tailgate sealing brackets and between the lower rear seal on the door and the door sealing stop assembly mounted on the tailgate.
- High pressure water washing at the top of the sliding glass panel of side sliding windows under the fixed pane will cause water to enter inside. Some water may also enter through the lower drain holes in side sliding windows frames.
- The canopy is designed to be weather proof in weather conditions.



SECTION 9: ARB FITMENT CHECKLIST (TO BE FILLED IN - RETAIN THIS RECORD).

To be completed by the installer and records kept at the dealer.

ARB – XCLS18 Mitsubishi Triton 24+ or XCLS19 Nissan Navara 26+ DC Classic Plus Canopy

Dealer Name and code:		Date:	
Vehicle registration:		Vehicle Vin No:	
Number of Kms:		Order No:	
Vehicle type: Mazda or Isuzu?		Canopy window type (tick):	
Canopy serial number: (On top of door brake light)		Side window type:	
		A - Double slider	<input type="checkbox"/>
		B - Lift up LH / Slider RH	<input type="checkbox"/>
		C - Lift up LH/ Lift up RH	<input type="checkbox"/>
		D - Lift up RH / Slider LH	<input type="checkbox"/>
		E - No side windows	<input type="checkbox"/>
		CA- Aluminium lift up RH&LH	<input type="checkbox"/>
		Front window:	
		Front Lift up	<input type="checkbox"/>
		Front Slider	<input type="checkbox"/>
Canopy Key Serial No (See code printed on keys)	_____ (DOOR) _____ (WIN)	Canopy Colour:	

Vehicle damage / condition check (details): **(Tick)**

Canopy positioned on tub front to back and side to side evenly and there is adequate clearance to the vehicle's cabin.	
The rear door glass has even gaps down both sides of the frame and there is adequate clearance for the door to close	
The lower edge of the rear door glass sits 8mm or more above the top of the tailgate and is even left to right.	
There is at minimum a 35mm gap between the front pillars of the canopy and the rear cabin pillars on the vehicle	
All screw torques completed as detailed in the instructions – ! Important !	
Door lower sash seal contacts the tailgate evenly without heavy force to close and seal and the tailgate sealing bracket seal to the tailgate and the tailgate closes without excessive force	
Lift up windows function with both keys to turn to lock and unlock	
Rear door key and electric locks operate without issue	
Water test with hose has been completed around all windows and join to canopy bed and at the roof vent / roof racks/ roof bars (if fitted) with no leaks other than through unsealed tailgate sides.	
Interior light works when turned on and off at the switch	
Canopy keys added to customer's key ring.	
Serial number recorded on the owner's supplement pages and owner's manual supplement copy given to the customer and explained.	
Comments:	
Fitted by:	
Checked by:	