

CONTROLLED DRAWING

REVISIONS

REV.	DESCRIPTION	BY	DATE	ECN No.
A	NEW TEMPLATE	JS	12/04/17	--

**BEFORE CUTTING
USE A RULER TO
CHECK TEMPLATE
IS TO CORRECT
SCALE**

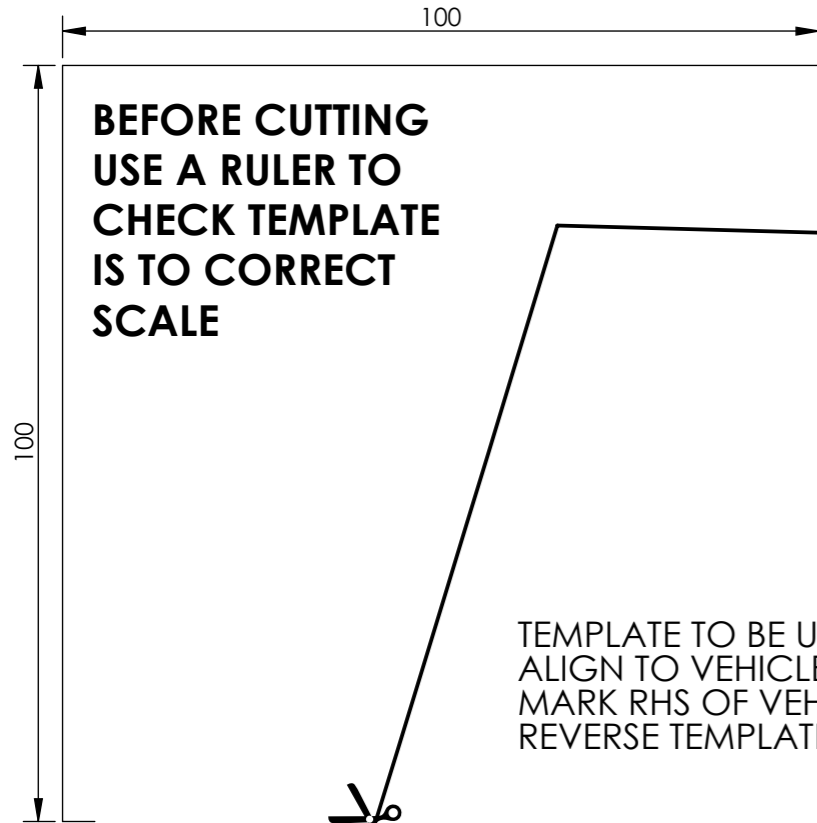

TEMPLATE TO BE USED FOR BOTH SIDES
ALIGN TO VEHICLE AS SHOWN IN FITTING INSTRUCTIONS.
MARK RHS OF VEHICLE,
REVERSE TEMPLATE TO MARK LHS

ALIGN WITH STYLE LINE OF TUB

ALIGN WITH EDGE OF WHEEL ARCH/ MUDFLAP

CUT WITH Ø70 HOLE SAW

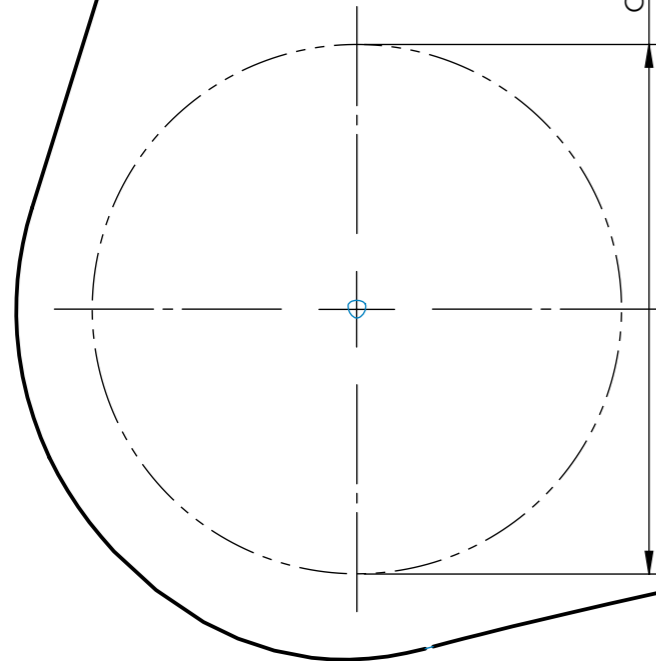

ALL BENDS 90° UNLESS SPECIFIED		REFER TO MATERIAL THICKNESS FOR BEND RADIUS, UNLESS OTHERWISE STATED		PROPRIETARY & CONFIDENTIAL <small>ALL RIGHTS RESERVED. THIS DRAWING MUST NOT BE COPIED OR USED FOR ANY PURPOSE WITHOUT THE EXPRESS AUTHORITY OF ARB CORPORATION LIMITED.</small>		ARB Corporation Ltd		TITLE: TEMPLATE-AMAROK RR QTR CUT				
MATERIAL THICKNESS	1.2 - 3 mm	4 - 6 mm	ANGULAR TOL.	LINEAR TOL.	DO NOT SCALE		GENERAL MATERIALS AND FINISH REQUIREMENTS REFER TO S01-069		MATERIAL: N/A	MASS (kg):		
INTERNAL BEND RADIUS	R1.0	R3.0	x° ± 1°	X ± 1.0	ALL DIMENSIONS IN MILLIMETERS		DETAILED J STUBBE 12/04/2017		FINISH: N/A			
FOLDING PARAMETERS				x.x° ± 0.5°	X.X ± 0.5	THIRD ANGLE PROJECTION		CHECKED A ZELOS 26/06/2017		PART NO.: 3789677	PAGE 1 OF 1	REV. A
- - - FOLD DOWN - - - FOLD UP REMOVE ALL BURRS & SHARP EDGES						SCALE 1:1	SIZE A3					