

# INSTALLATION INSTRUCTIONS



## **R2004 - TO SUIT TOYOTA KLUGER 11/03-ON**

### **PLEASE READ INSTRUCTIONS THROUGH BEFORE YOU BEGIN**

#### **WARNING:**

1. Do not, drill, cut weld or otherwise modify the towbar.
2. If you are using electric welding on a motor vehicle, always check that the vehicle is not equipped with electronic engine or instrument management equipment. Failure to do so could destroy any onboard computers. If in doubt, check with the vehicle's manufacturer.

Max. Towing Weight: 1500

1. Ensure all hardware items have been included.
2. Remove 2x plastic trim buttons from spare wheel tool compartment and remove tray.
3. Undo 4x 10mm nuts from back side of bumper in tool compartment cavity.
4. Undo 2x screws from top centre of bumper bar.
5. Undo 4x screws from either side bottom corner of bumper bar or 2x plastic trim buttons.
6. Remove mud guards via 8x Socket Head Cap (Allen key) screws and remove bumper bar.
7. Remove foam bolster and impact beam via 6x12mm nuts.
8. Fit towbar and tighten 4x M10 bolts to specified torque.
9. Fit and tighten 6x M8 nuts to specified torque.
10. Refit foam bolster and cut out to clear towbar.
11. Mark and cut bumper.
12. Refit bumper, mud guards and tool compartment.

**NOTE:** Hayman Reese recommends that you check your towball to ensure it complies to Australian Design Rules.

#### **RECOMMENDED ASSEMBLY TORQUE LISTING**

<b><u>Diameter</u></b>	<b><u>Grade 8.8 Bolt</u></b>
	<b>Nm</b>
M6	9.5
M8	21.7
M10	43.4
M12	77.3
M16	189.8

#### **FOR TOWING PURPOSES ONLY**

For towing capacity details please refer to vehicle owner's manual or to the manufacturer. Overloading can void your warranties.

**PLEASE NOTE:** You must remove the lug unless you are actually towing if it obscures your number plate. Failure to do so may result in a fine.

16-09-08.

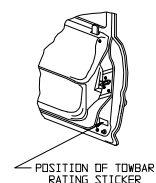

# INSTALLATION INSTRUCTIONS cont'

## R2004 - TO SUIT TOYOTA KLUGER 11/03-ON

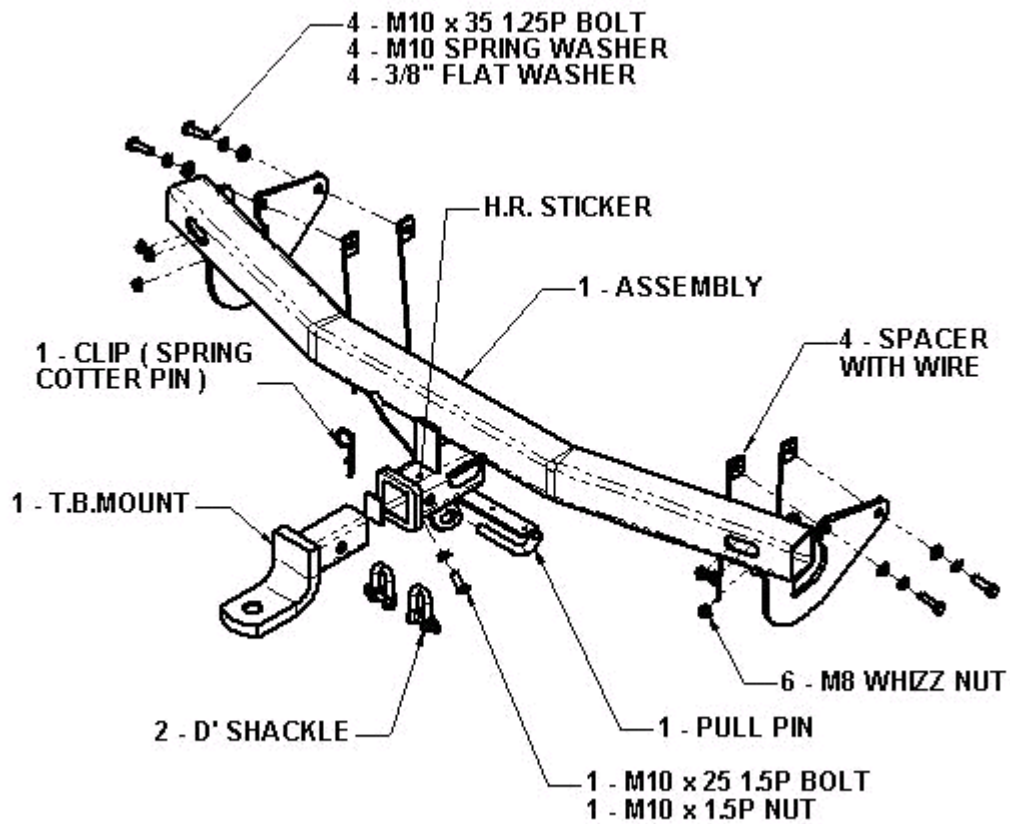

Cut out bumper as shown

