



TOWBAR INSTALLATION INSTRUCTIONS

PART NUMBER 03350RW

JEEP GRAND CHEROKEE WK MY20 CL4



PRODUCT DETAILS:

Part Number:	03350RW	Maximum Towing Braked:	3500	kg
ECU Number:	04826	Maximum Towing Unbraked:	750	kg
Tail Harness Length Required:	1800 mm	Maximum Static Ball Load:	350	kg
TBM/Lug Part Number:	21161			
Wiring Part Number:	101410-WL			

FITTING DETAILS:

Towbar Installation Time:	80 Mins.	Hayman Reese SmartCODE Solution Required:	NO
Wiring Installation Time:	60 Mins.	RPA Disable/Other:	NO
Total Installation Time:	140 Mins.		
Bumper Cut Required:	Yes	Note:	

- The RPA is disabled via a button on the dash panel.



TOWBAR INSTALLATION INSTRUCTIONS

PART NUMBER 03350RW

JEEP GRAND CHEROKEE WK MY20 CL4

ENSURE THAT INSTRUCTIONS ARE UNDERSTOOD PRIOR TO FITMENT.

i BEFORE YOU START:

Hayman Reese recommends that instructions are read completely prior to fitment. Check all hardware items have been included refer to assembly diagram. Please ensure this towbar is only fitted to vehicle models as per Hayman Reese application guide (www.haymanreese.com.au).

Bumper Cuts



Vehicle and bumper variations can and do occur during vehicle manufacture after initial towbar design. Fitment of towbar to vehicle and accuracy of bumper cut must be assessed prior to any bumper modifications made. Incorrect bumper cuts are not covered under Hayman Reese warranty.

NOTE: Bumper cuts need to be approached with care, refer to notes below.

- Bumper centreline – where the centreline of the bumper needs to be determined, the installer must assess centre point by measurement of bumper width or determining two symmetrical reference points to give centreline.
- Bumper edge – To assist with accurate bumper cut measurement, reference to the start of the bumper edge is now being commonly used.
 - Measure from bottom edge along bumper and around corner to the 70 mm point (Figure 1).
 - Do not measure from visible bumper front of corner, upwards (Figure 2).

CORRECT

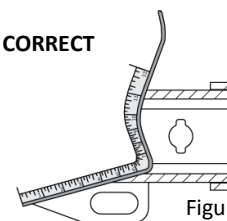

Figure 1

INCORRECT

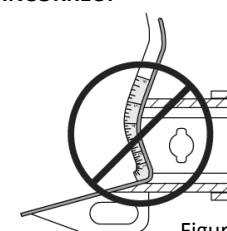

Figure 2

Drilling

- For any required drilling during installation, ensure that the area is clear of fuel, electrical & other components that may be damaged.
- All holes drilled into the body panels shall have all burrs & swarf removed then coated with a suitable rust preventative paint.

Bolts/Fasteners

- Ensure that all hardware is fastened to correct torque as specified in this fitting instruction.
- All fasteners supplied with this product are used to achieve a specified clamp loading. If replacement is required ensure that fasteners of the same grade and class are used.



NOTE: Achieving correct torque is critical to proper installation and responsibility of the installer. Towbar failures attributed to tension issues from over tightening or under tightening are not covered by Hayman Reese warranty.

Product Labels

- a. Towbar load rating sticker provided with this product shall be conspicuously located on inside rear end of the driver's door.
- b. Powertrain Control Module (PCM)/Body Control Module (BCM) upgrade warning label will be provided in towbar kit for vehicles as required. Affix warning label in door and owner's handbook.

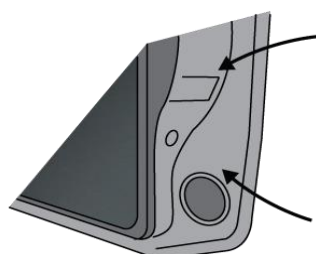

Place **Load Rating sticker** inside driver's door here

Place **Vehicle PCM/ BCM upgrade warning label** in door AND on front cover of owner's service handbook

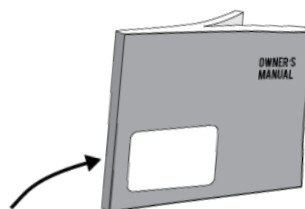

WARNING:

Do not, drill, cut, weld or otherwise modify the towbar.

FOR TOWING PURPOSES ONLY - This towbar is designed and tested by Hayman Reese to adhere to ADR 62/02 which provides only for the expected load demands of towing.



TOWBAR INSTALLATION INSTRUCTIONS

PART NUMBER 03350RW

JEEP GRAND CHEROKEE WK MY20 CL4

i TOWBAR ASSEMBLY DIAGRAM

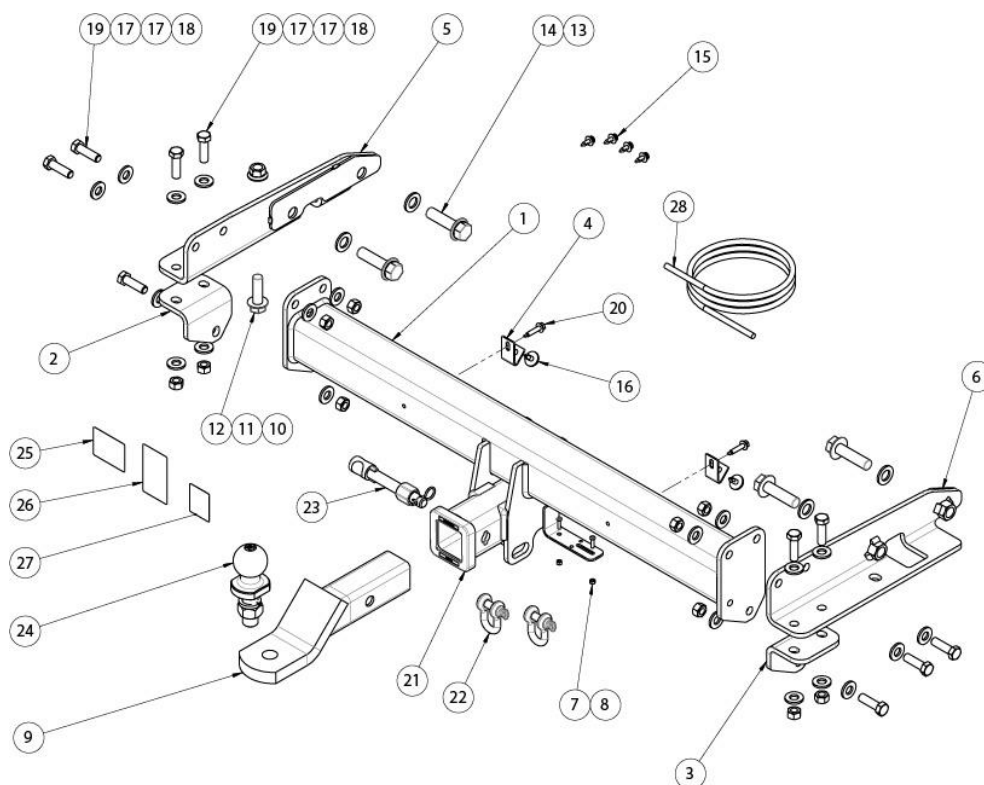

ITEM	DESCRIPTION	QTY
1	GRAND CHEROKEE WELDED ASSY.	1
2	SIDE SUPPORT LH	1
3	SIDE SUPPORT RH	1
4	BUMPER TAB	2
5	SIDE ARM ASSY LH	1
6	SIDE ARM ASSY RH	1
7	NUT NYLOC HEX HD M4x0.7P	2
8	SCREW PAN HD M4x16x0.7P	2
9	TRAILER BALL MOUNT	1
10	NUT HEX FLANGE LOCK M14x1.5P	2
11	WASHER PLAIN M14x28x2.5	2
12	BOLT HEX FLANGE M14x45x1.5P	2
13	WASHER PLAIN M16x30x3	4
14	BOLT HEX FLANGE M16x60x1.5P	4

ITEM	DESCRIPTION	QTY
15	SCRIVET CFZ-020-0034	4
16	SKRIVET - 010 - 0175	2
17	WASHER PLAIN 1/2"	20
18	NUT HEX HD M12x1.25P	10
19	BOLT HEX HD M12x40x1.25P	10
20	TEK SCREW 14-20 HEX HD 22mm	2
21	HITCH BOX COLLAR COVER	1
22	"D" SHACKLE 10mm	2
23	SMART PIN GOLD	1
24	TOWBALL 50mm	1
25	COMPLIANCE LABEL	1
26	LOAD RATING LABEL	1
27	HAYMAN REESE LOGO STICKER	1
28	WIRING LOOM	1



TOWBAR INSTALLATION INSTRUCTIONS

PART NUMBER 03350RW

JEEP GRAND CHEROKEE WK MY20 CL4

1. Open tailgate and remove 1 x torx screw from the LH side and RH side of bumper.
(LH side shown)

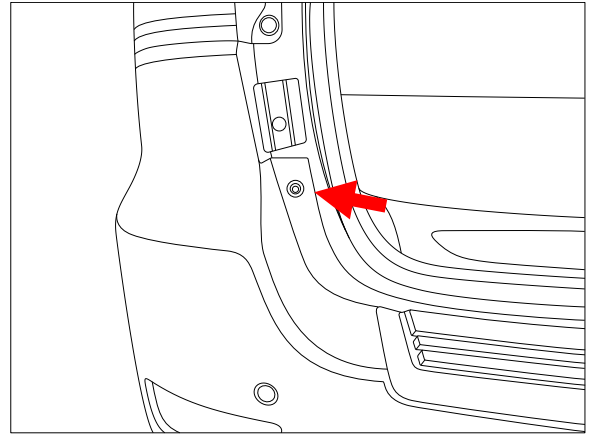

2. In wheel arch, remove 2 x Hex screws, 2 x scrivets and 2 x plastic rivets (use a 3-5mm drill to drill out the centre of the plastic rivets).

Repeat for the other side.

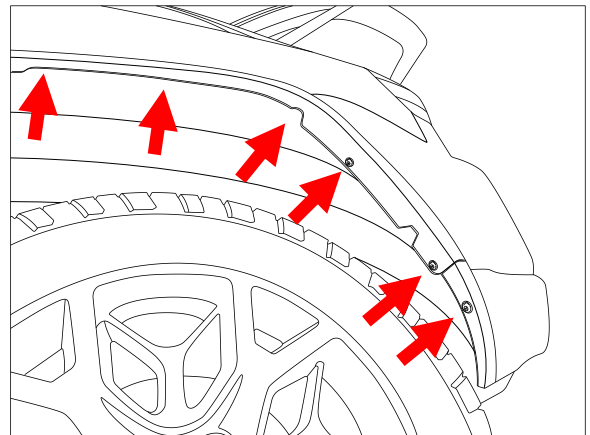

3. Remove the wheel skirting from the vehicle secured with 3 x clips on the bumper and 3 x plastic push in rivets from the body panel.

Repeat for other side.

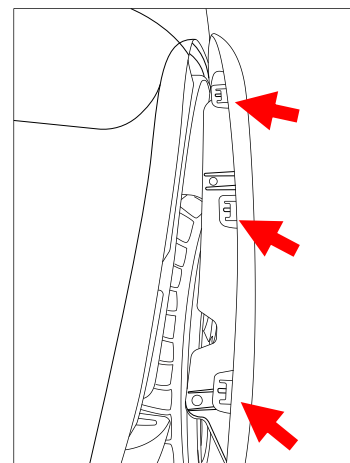



TOWBAR INSTALLATION INSTRUCTIONS

PART NUMBER 03350RW

JEEP GRAND CHEROKEE WK MY20 CL4

-
4. Remove 1 x Hex screw from bumper.

Repeat for other side

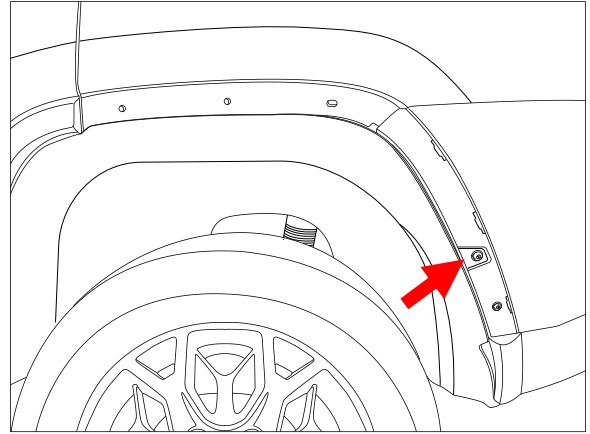

-
5. From under bumper, remove and discard the 2 x bolts securing the bumper tabs to the impact beam.

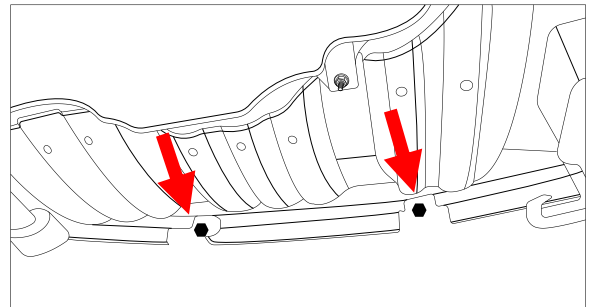

-
6. Peel bumper away from edges and remove from vehicle. Ensure to disconnect the wire harness plug located on the LH side.

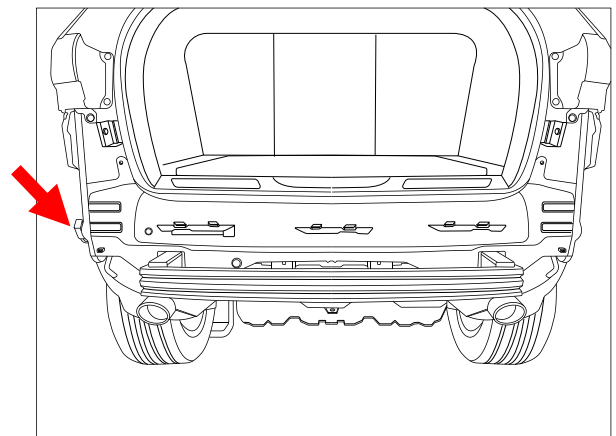

7. Disconnect the muffler from the exhaust pipe secured with 2 x nuts and swing the exhaust muffler out of the way (still on hanger bracket) to assist with towbar fitment. Alternatively remove the exhaust from the 2 x hanger brackets.

Repeat for other side.

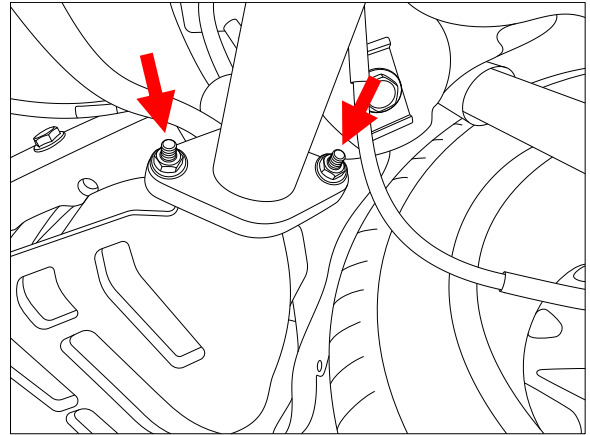

8. On LH side, loosen the 6 x bolts securing the recovery towhook and impact beam to the chassis and body. Remove and **discard only the bolts A, B, C**. The remaining bolts remain in position and are used during the side arm installation (Step 10).

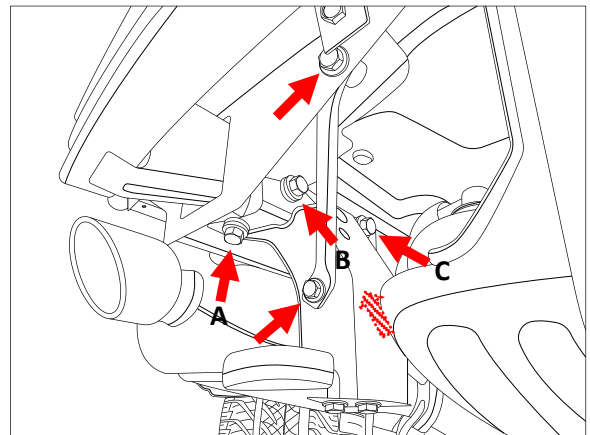

9. On RH side remove the 3 x bolts securing the impact beam to the chassis

Remove and discard impact beam.

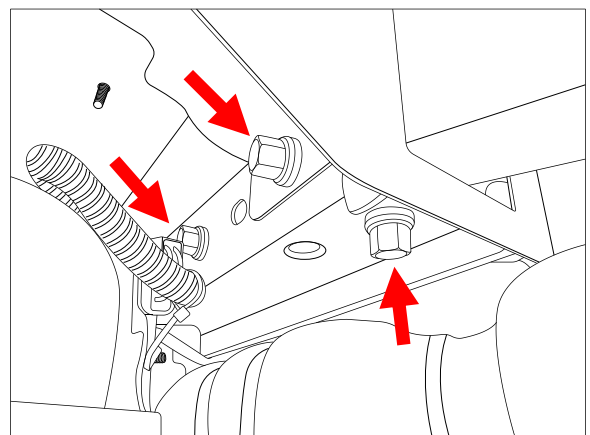



TOWBAR INSTALLATION INSTRUCTIONS

PART NUMBER 03350RW

JEEP GRAND CHEROKEE WK MY20 CL4

10. Insert RH side arm into the chassis rail and loosely secure the sides with 2 x M16 flange bolts complete with 1 x washer per bolt and from under the chassis 1 x M14 flange bolt complete with 1 x washer and 1 x flange nut.

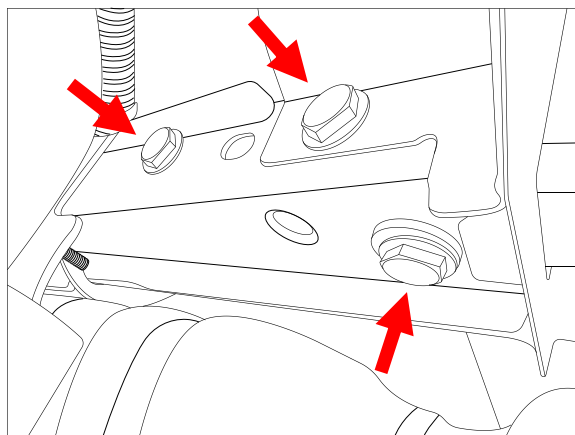

11. Insert LH side arm into the chassis rail, and with the recovery hook in position, loosely secure the sides with the supplied 2 x M16 flange bolts complete with 1 x washer per bolt and from under the chassis with 1 x M14 flange bolt complete with 1 x washer and 1 x flange nut. Ensure the recovery hook bolts loosened in step 8 remain in position.

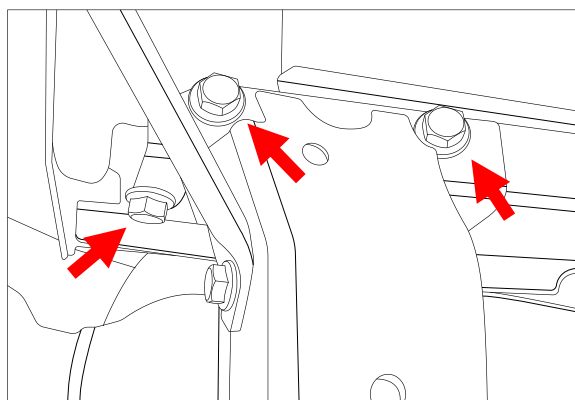

12. Loosely attach the 2 x bumper tab brackets to the rear of the crosstube using the supplied Tek screws. The tek screw goes through the slotted section to allow for final positioning.

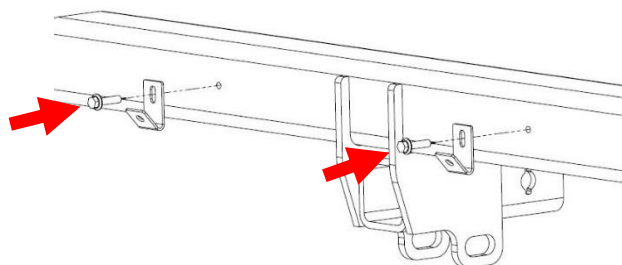



TOWBAR INSTALLATION INSTRUCTIONS

PART NUMBER 03350RW

JEEP GRAND CHEROKEE WK MY20 CL4

13. Raise the crosstube to the side arms and on each side, loosely secure the top holes with 2 x M12 bolts complete with 2 x washers and 1 x Nut per bolt

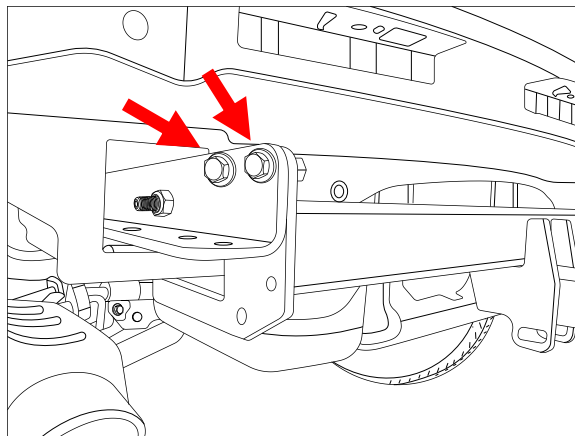

14. Position the angle bracket onto the side arm and crosstube assembly and loosely secure with 3 x M12 bolts complete with 2 x washers and 1 x nut per bolt.

Repeat for other side.

Tighten all fasteners to the following torques:

M12 Gr 8.8 : 89Nm

M14 Gr 10.9 : 125Nm

M16 Gr10.9 : 160Nm

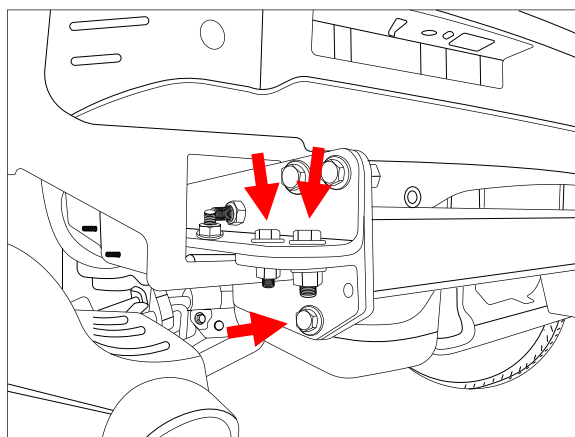

15. For bumper cut.

Determine the centre of the towbar. On the outside, measure, mark off and cut out a section 90mm wide and 130mm long, measured from the bottom edge of the bumper.

Ensure to not cut through any wiring or sensors.

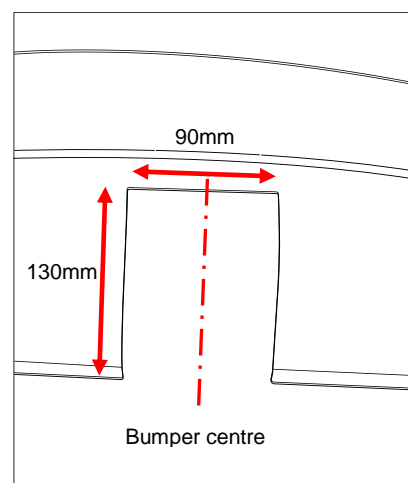



TOWBAR INSTALLATION INSTRUCTIONS

PART NUMBER 03350RW

JEEP GRAND CHEROKEE WK MY20 CL4

IMPORTANT

Due to possible vehicle variations, always confirm any noted vehicle colour wires with a multi-meter to ensure the correct function is identified before soldering or scotch locking. For vehicle wires denoted with two colours (example; RED/GREEN) the first colour will always be the main wire colour while the second colour is the thinner trace colour on the wire.

16. In the luggage compartment area, remove the following:
- floor carpet (1)
 - fold forward the rear passenger seats (2).

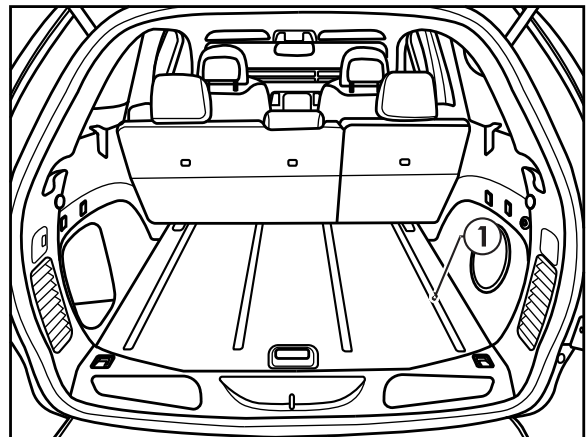

17. Remove the tool trays (1).
18. Remove any required fasteners to remove the spare wheel (2) and the spare wheel surround trim (3).
19. Remove the rear trim (4).
20. Remove any required fasteners to remove the RHS and LHS luggage compartment trims (5).

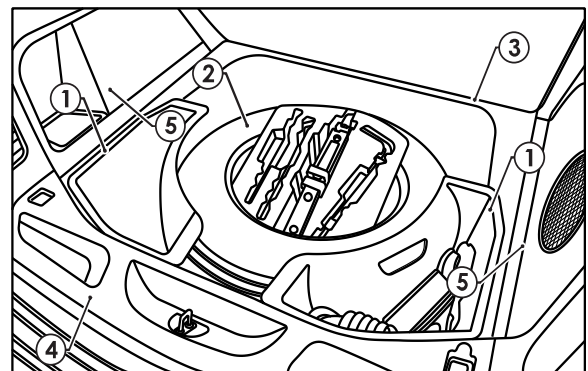



TOWBAR INSTALLATION INSTRUCTIONS

PART NUMBER 03350RW

JEEP GRAND CHEROKEE WK MY20 CL4

21. Disconnect the LHS break-out connectors (1) and patch the trailer patch (P/No:101410-WL) connectors (2) in between.
22. Secure the trailer patch ground ring terminal (3) to the vehicle grounding point (4).
23. Following the table below, connect the ezy-tap (5) to the corresponding vehicle wire (6), then connect the trailer patch terminal (7) to the ezy-tap (1).

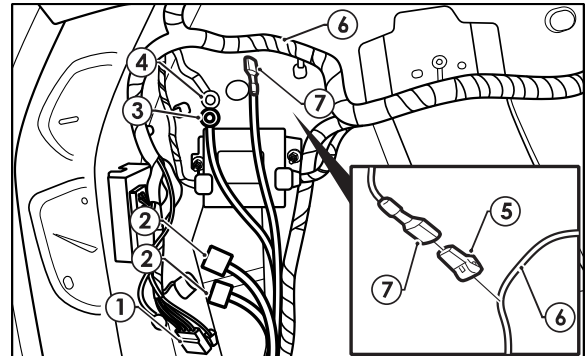

Function	Trailer Patch Wire	Vehicle Harness Wire
REVERSE	BLACK / WHITE	WHITE / GREEN

24. Connect the trailer patch (1) to the ECU (P/No:04826) (2).
25. Locate a suitable location on the LHS sheet metal area to mount the ECU (2). Clean the chosen area with an alcohol wipe (not supplied).
26. Remove the backing from the back of the ECU and mount the ECU (2) to the cleaned area. **Ensure the ECU connector is pointing downwards.**

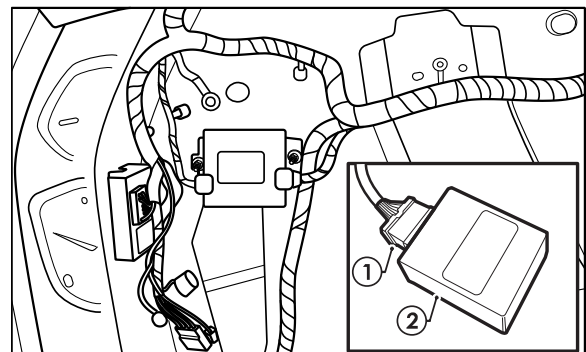

27. Remove the following required trims on the RHS of the vehicle to allow for harness routing:
 - remove RHS rear passenger scuff
 - remove the driver's scuff trim



TOWBAR INSTALLATION INSTRUCTIONS

PART NUMBER 03350RW

JEEP GRAND CHEROKEE WK MY20 CL4

28. From the LHS rear quarter, route the trailer patch power ring terminal branch (1) across the rear of the vehicle to the RHS rear quarter and then follow the vehicle RHS harness to the battery underneath the driver's seat.
29. Secure the trailer patch power ring terminal (1) to the vehicle positive (2) using the existing vehicle fastener. Be careful when removing the positive nut not to short your tool on the vehicle!

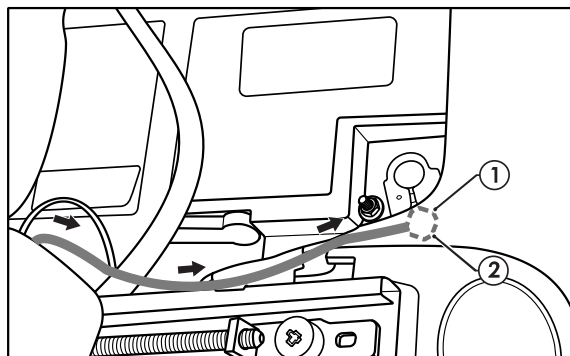

30. On the exterior LHS rear quarter of the vehicle, locate a suitable location on the vehicle sheet metal to drill a 30mm hole (1) into the luggage compartment area to allow for harness routing. **Ensure area being drilled into is free from any obstruction or vehicle parts.** Apply rust inhibitor after drilling.

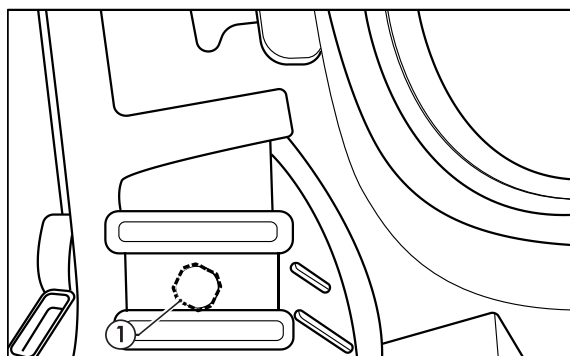

31. At the rear exterior of the vehicle, mount the tail harness socket (1) to the towbar mounting bracket using M4 fasteners (not supplied).
32. Route the tail harness (tail length: 1800mm) (2) across the LHS and up into the drilled out hole (3).

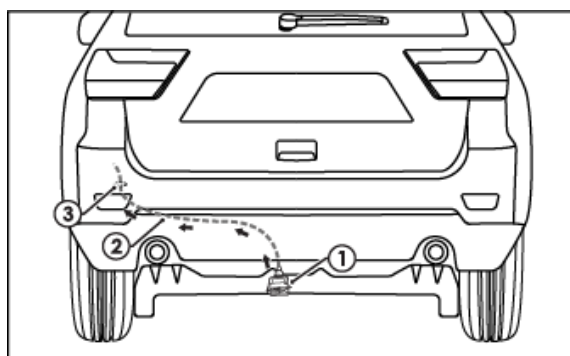



TOWBAR INSTALLATION INSTRUCTIONS

PART NUMBER 03350RW

JEEP GRAND CHEROKEE WK MY20 CL4

33. Route the trailer patch GREEN / BLACK wire branch (1) through the grommet and the bumper cavity, across to the RHS.
34. Adjust the trailer patch harness grommet (2) so that it is seated correctly and cable tie (not supplied) into place.

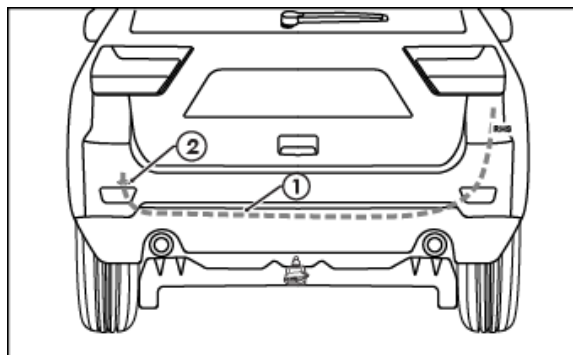

35. Route the trailer patch YELLOW / BLACK wire branch (1) through the grommet and the bumper cavity, up to the LHS.

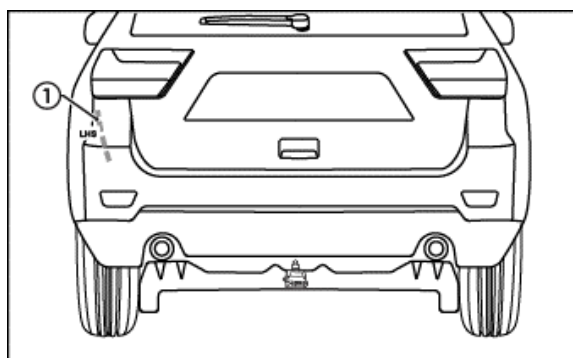

36. At the vehicle exterior, carefully cut open the vehicle harness at the indicated point just below the RHS tail light (1).
37. Following the table below, solder the trailer patch GREEN/BLACK R.IND wire to the corresponding vehicle WHITE/YELLOW tail light wire, then waterproof the connection after.

Function	Trailer Patch Wire	Vehicle Harness Wire
R.IND	GREEN / BLACK	WHITE / YELLOW

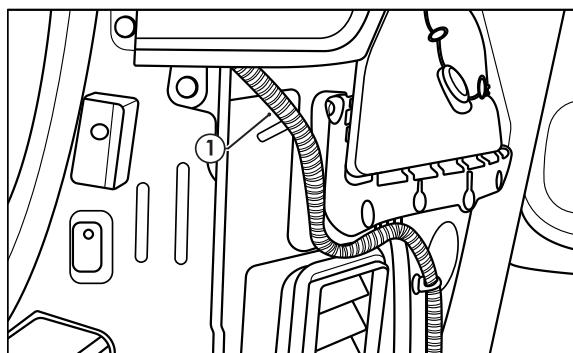



TOWBAR INSTALLATION INSTRUCTIONS

PART NUMBER 03350RW

JEEP GRAND CHEROKEE WK MY20 CL4

38. At the vehicle exterior, carefully cut open the vehicle harness at the indicated point just below the LHS tail light (1).
39. Following the table below, solder the trailer patch YELLOW/BLACK L.IND wire to the corresponding vehicle WHITE/GREEN tail light wire, then waterproof the connection after.

Function	Trailer Patch Wire	Vehicle Harness Wire
L.IND	YELLOW / BLACK	WHITE / GREEN

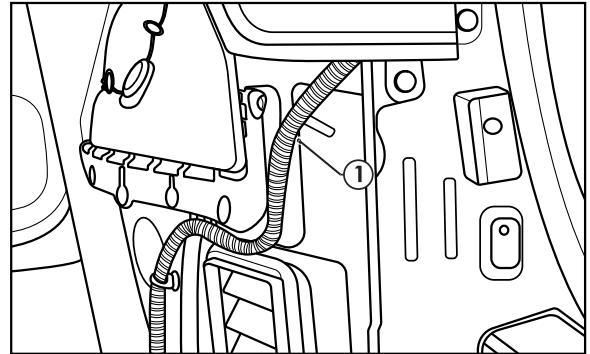

40. Inside the luggage compartment, connect the tail harness 8-way connector (1) to the trailer patch 8-way mating connector (2).

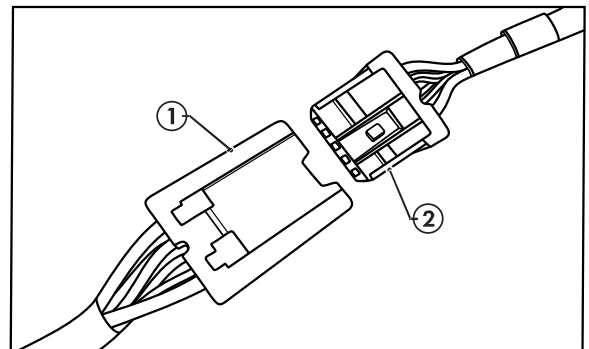

41. Secure all harnesses using cable ties (not supplied).
42. Refit bumper and other removed parts following steps 7-1.
43. Use the 4 x 6mm push scrivenets to replace the removed plastic rivets where used in the wheel arch (step2).
44. Refit all interior panels following steps 16-20.

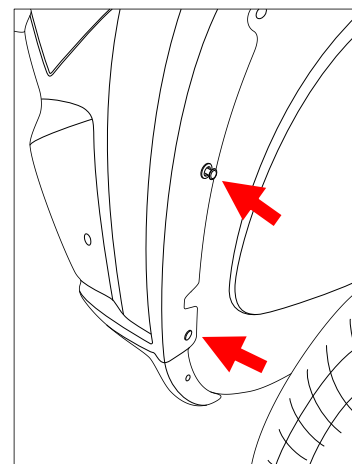



TOWBAR INSTALLATION INSTRUCTIONS

PART NUMBER 03350RW

JEEP GRAND CHEROKEE WK MY20 CL4

-
45. Use the supplied 8mm scrivenets to reattach the 2 x bumper tabs to the bumper brackets.
Position and secure the bumper tab brackets with the Tek screws (pre fitted step 12). Avoid overtightening that could cause the Tek screw thread to strip.

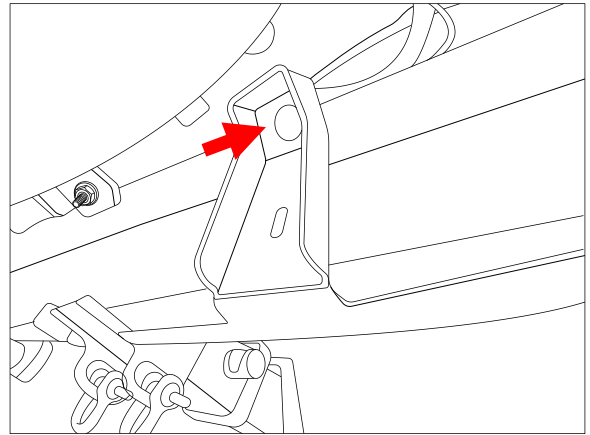

-
46. Test the Trailer Harness function using a Light Board or multi-meter.
47. Secure all harnesses using cable ties (not supplied).
48. Place instructions in glove box after fitment.
49. The RPA can be disabled via a button (1) on the dash panel.

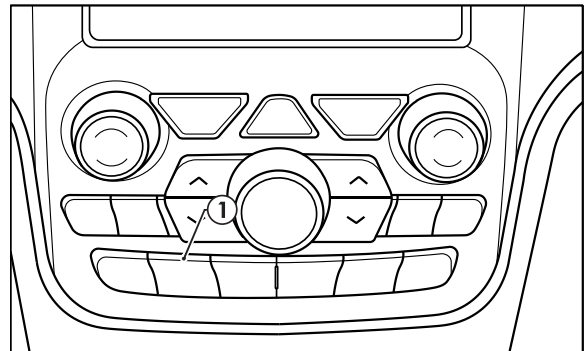



CUSTOMER INFORMATION

PLACE THESE INSTRUCTIONS IN THE
VEHICLE'S GLOVEBOX AFTER INSTALLATION

**THANK YOU FOR PURCHASING HAYMAN REESE.
WITH CORRECT MAINTENANCE AND CARE THIS PRODUCT WILL PROVIDE A
LIFETIME OF TROUBLE-FREE OPERATION.**

i TOWBAR MAINTENANCE AND CARE:

1. Hayman Reese recommend that the towbar LUG or TBM (tow ball Mount) Pull Pin and R-clip are removed and stored when not in use. Removal of LUG or TBM (tow ball mount) is advisable when not in use to assist with any of the following.
 - Ensure rear number plate is not obscured.
 - Allow maximum available departure angle and prevent any potential interference.
 - Prevent possible interference with vehicles reverse sensors or camera detecting a tow ball mount as an obstruction during reversing.
 - Removes towball mount as an obstruction for when moving around the rear of the vehicle.
2. Hayman Reese recommends routine inspection of your towbar to ensure trouble free towing.
 - Bolt security and tension should be regularly inspected and checked for correct tension. Replace any worn or defective parts with suitable grade & class fasteners. Inspection should be requested to coincide with vehicle major services.
3. It is the owner's responsibility to ensure towing and down ball weight capacities of the towing vehicle are not exceeded.
 - Towing and down ball weights allowable may differ according to model variations. Please refer to owner's manual or vehicle dealer to confirm exact rating for your vehicle model variant.
 - It is not uncommon for the vehicle tow rating to differ from the towbar rating. When this occurs, the lesser rating must be adhered to.
 - For vehicles fitted with enhanced vehicle functions that may be altered/changed when towing i.e Trailer sway mitigation, blind spot detection, adaptive cruise control etc. Please consult owner's manual to understand changes enabled when towing and after towing.

i WARRANTY INFORMATION:

Hayman Reese Towbars are covered by a Lifetime Warranty.

Our goods come with guarantees that cannot be excluded under the Australian Consumer Law. You are entitled to a replacement or refund for a major failure and for compensation for any other reasonably foreseeable loss or damage. You are also entitled to have the goods repaired or replaced if the goods fail to be of acceptable quality and the failure does not amount to a major failure.

For further details please visit www.haymanreese.com.au/warranty or contact customer service on 1800 812 017 or info@haymanreese.com.au.



CUSTOMER INFORMATION

PLACE THESE INSTRUCTIONS IN THE VEHICLE'S GLOVEBOX AFTER INSTALLATION

HAYMAN REESE SMART PIN

Your Hayman Reese towbar is equipped with Smart Pin technology to help reduce towbar tongue rattle in most driving conditions. Please ensure below instructions are understood and routine maintenance is carried out to ensure best towing experience.

i Regularly inspect for wear and check the tightness of the Smart Pin Nut. Follow instructions below to re-tighten the nut as necessary when movement and noise in the tow ball mount is noted.

- Before towing, ensure R-Clip is properly installed and Smart pin nut is installed and tensioned. Replacement parts are available from your Hayman Reese Distributor.

TOWBALL MOUNT REMOVAL/INSTALLATION

STEP 1

Insert Trailer Ball Mount (TBM) (a) into towbar hitchbox (b), aligning hole in TBM shank (c) with hole in hitchbox (d) (Fig. 1)

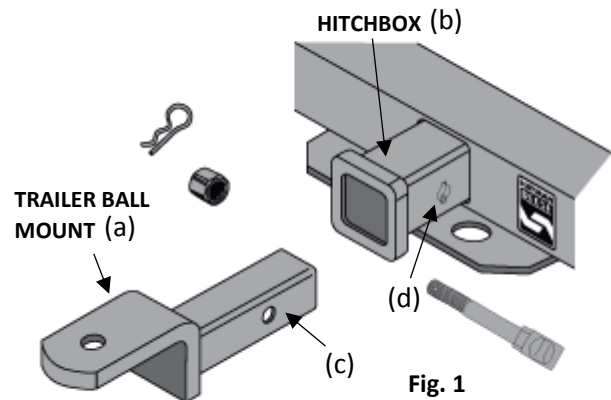

STEP 2

Insert Smart Pin (e) through hole in hitchbox and hole in TBM shank (g); ensure the locators are inserted into the notches in the hitchbox (Fig. 2)

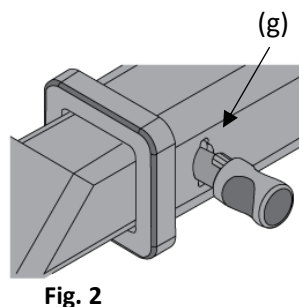

STEP 3

Screw Smart Pin Nut (f) onto Smart Pin (g); tighten Smart Pin Nut until finger tight, ensuring TBM is restrained from up and down movement.

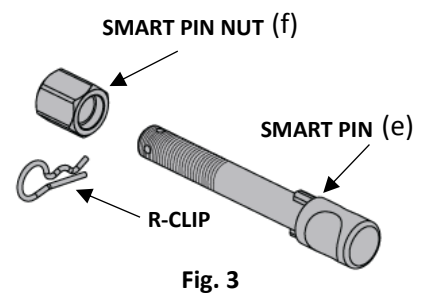

STEP 4

Tighten Smart Pin Nut by turning nut a further 1/8th of a turn in the clockwise direction using a 24mm spanner (Fig. 4).

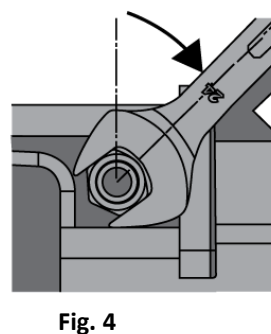

STEP 5

Install Smart Pin R-Clip through the hole that provides best clearance or easiest access. (Fig. 5)

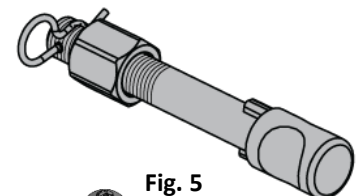

STEP 6

Install towball onto TBM and tighten to **350 Nm** using a calibrated torque wrench (Fig. 6).

