

WARNINGS & SAFETY INSTRUCTIONS

SAVE THESE INSTRUCTIONS — this manual contains important safety instructions. Do not operate the system unless you have read and understood this manual.

REDARC recommends that the products referenced in this manual be installed by a suitably qualified person.

Disclaimer: REDARC accepts no liability for any injury, loss or property damage which may occur from the improper or unsafe installation or use of its products.

SAFETY MESSAGE CONVENTIONS

Safety messages in this manual include a signal word to indicate the level of the hazard as follows:

▲ WARNING — Indicates a potentially hazardous situation which, if not avoided, could result in death or serious injury to the operator or to bystanders.

▲ CAUTION — Indicates a potentially hazardous situation which, if not avoided, may result in moderate or minor injury to the operator or to bystanders.

NOTICE — Indicates a situation that may cause equipment damage.

▲ WARNING

When using this product, basic precautions should always be followed, including the following:

1. **RISK OF EXPLOSIVE GASES** — Working in the vicinity of a lead-acid battery and Lithium-ion technologies is dangerous. Batteries may generate explosive gases during normal operation. Prevent flames and sparks, and provide adequate ventilation especially during charging.

To reduce risk of battery explosion, follow these instructions and those published by the battery manufacturer and manufacturer of any equipment you intend to use in vicinity of the battery.

2. **DO NOT** drop metal tools onto a vehicle battery. Doing so might cause the battery to spark or might short-circuit the battery or other electrical parts, which may cause an explosion.

3. **NEVER** smoke or allow a spark or flame in vicinity of battery or engine.

4. **RISK OF FIRE** — **DO NOT** install this product in the same compartment where flammable substances are stored, such as petrol/gasoline or Liquefied Petroleum Gas (LPG).

5. The Heated Lithium (H) charging profile should only be used with lithium batteries that feature a functioning heating element. If unsure, the Standard Lithium (L) charging profile must be used. Using the wrong charging profile may damage your lithium battery.

6. Check the manufacturer's data for your battery and ensure that the maximum voltage of the profile you select does not exceed the manufacturer's recommended maximum charging voltage. If the maximum voltage is too high for your battery type, select another charging profile.

7. These products should not be used for any medical purposes, life sustaining equipment, safety applications, or any application where equipment failure can cause injury, death, fires or any other hazard.

8. **DO NOT** put fingers or hands into the product.

9. No user serviceable parts inside. **DO NOT** attempt servicing this product. Have servicing performed by a qualified repair person using only identical replacement parts. This will ensure that the safety of the product is maintained.

10. **DO NOT** use the ICMS if damaged or modified. Damaged or modified products may exhibit unpredictable behaviour resulting in fire, explosion or risk of injury.

11. Incorrect handling or disassembly/reassembly may result in a risk of fire. Any attempt to disassemble/reassemble the ICMS, or make unapproved repairs or modifications will void the warranty and the user's authority to operate the ICMS.

12. **DO NOT** expose the ICMS to temperatures beyond the published limits.

13. **DO NOT** operate the ICMS beyond the published ratings. Doing so may result in damage to the ICMS, fire, explosion and burns/personal injury.

14. **PERSONAL PRECAUTIONS:** To assist with the safe operation and use of the ICMS when connected to the battery:

- a. Consider having someone close-by to come to your aid if you are working near a lead-acid battery.

- b. Remove personal metal items such as rings, bracelets, necklaces, and watches before working with a vehicle battery. A vehicle battery can produce a short-circuit current high enough to weld a ring or the like to metal, causing a severe burn.

- c. Have plenty of fresh water and soap nearby in case battery acid contacts skin, clothing, or eyes.

- d. Wear complete eye protection and clothing protection. Avoid touching eyes while working near battery. If battery acid contacts skin or clothing, wash immediately with soap and water. If acid enters eye, immediately flood eye with running cold water for at least 10 minutes and seek medical attention immediately.

- e. Use suitable Personal Protective Equipment (PPE) when operating power tools.



- f. If battery acid contacts your skin or clothing, remove the affected clothing and wash the affected area of your skin immediately with soap and water. If battery acid enters your eye, immediately flood the eye with running cold water for at least 10 minutes and seek medical assistance immediately.

- g. **HOT SURFACE:** High amperage loads connected to the Battery Monitor can cause the terminals and metal components to become extremely hot. To avoid burns, do not touch the hot parts without suitable personal protective equipment.

▲ CAUTION

15. Selecting the wrong cable or fuse size could result in harm to the installer or user and/or damage to the battery or other equipment installed in the system. The installer is responsible for ensuring that all installer-supplied cables and fuses are the correct size and type (i.e. has physical performance properties and ratings suitable for the install conditions).

16. The system should not be used by persons under the age of 18, or those with reduced physical, sensory or mental capabilities or lack of experience and knowledge unless they are supervised and under instruction.

17. Cabling must be installed in protected areas away from heat sources, sharp objects or over/through parts of the vehicle that move during operation or maintenance. Supplementary protection such as conduit may be required, especially when installing or routing in the engine bay.

18. **DO NOT** use this product to control safety critical devices or those that could cause harm if operated remotely (for example fume exhaust fans or lifters). Only operate devices with moving parts when you have a clear line of sight to the moving parts.

NOTICE

19. REDARC recommends only using genuine Anderson™ connectors for ICMS installations. Counterfeit or generic connectors may result in a poor quality connection. For Anderson SB50 connector wiring instructions, refer to the 'SB@ Connector Assembly Sheet' available on the Anderson Power Products website.

20. The installer is responsible for applying the correct torque to the Terminal Bolts on the Battery Monitor. Over-torquing bolts may damage the Terminals.

21. **DO NOT** bottom-out the bolt threads when fastening Terminal Bolts to the Battery Monitor Terminals, this may cause a poor electrical connection.

LIMITED WARRANTY

For full warranty terms and conditions, visit the Warranty page of the REDARC website: www.redarcelectronics.com/warranty

Australia, New Zealand, UK & Europe:

REDARC Electronics Pty Ltd

23 Brodie Road (North), Lonsdale SA 5160, Australia

North America:

REDARC Corporation, c/o Shalco, Inc.

308 Component Dr. Smithfield, NC 27577, USA

ADDITIONAL RESOURCES

The individual manuals for REDARC devices in your system are available to download online.



BCDC Core
Instruction Manual



Battery Monitor
Instruction Manual



RedVision
Configuration Guide

Tech Support

1300 REDARC (1300-733-272)

Australia

+61 8 8322 4848

New Zealand

+64 9 222 1024

UK & Europe

+44 (0)20 3930 8109

USA

+1 (704) 247-5150

Canada

+1 (604) 260-5512

Mexico

+52 (558) 526-2898

redarcelectronics.com

INST393-1 EN

REDARC

REDWORKS

SCOUT 25/40

12V 25 A / 40 A Integrated Power System

MODELS:

- ICMS-015-001 (25 A)
- ICMS-015-002 (40 A)



THE SCOUT^{25/40}

12V 25A/40A INTEGRATED POWER SYSTEM

The Scout 25/40 is a compact dual battery system with battery monitoring, ideal for weekend adventurers delivering reliable power without complexity. Equipped with genuine Anderson™ SB50 connectors, the Scout 25/40 is ideal for powering 12V fridges, small compressors, LED lights and charging devices like phones, tablets and portable speakers.

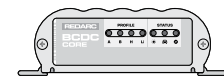

BCDC CORE BATTERY CHARGER

Designed to keep your vehicle's auxiliary battery system fully-charged and can source power from 12V or 24V vehicle alternators and 12V solar panels.



SMART BATTERY MONITOR

Provides critical system data including battery voltage, current, temperature and State of Charge (SoC) via the RedVision® User App.

INSTALL THE SCOUT 25/40



THE SCOUT 25/40 INSTRUCTION MANUAL

Scan the QR Code to view the Scout 25/40 Instruction Manual.

This contains essential installation guidance and operation details of the Scout 25/40 for both simple and advanced system configurations.

SYSTEM CONFIGURATION AND OPERATION



DOWNLOAD THE FREE CONFIGURATOR APP

Once the installation is complete, download the Configurator App to define the Scout's behaviours and operation, and your auxiliary battery's specifications.

DOWNLOAD THE FREE THE REDVISION® APP

The RedVision App gives you remote access to the Scout's functions and features including battery voltage, current, temperature and State of Charge (SoC) of the connected battery.

SPECIFICATIONS

Weight	3.6kg (7.9 lbs)
Dimensions	330 × 235 × 76 mm (13" × 9.25" × 3")
Operating Temperature Range	-15°C to 60°C (5°F to 140°F)

WHAT'S IN THE BOX?

- SCOUT 25/40 INTEGRATED POWER SYSTEM**
- Mounting Points (x4)
Refer to the supplied Mounting Template for mounting instructions.
- FRONT COVER**
- M5 × 12 mm Cover Screws (x4)
- BCDC CORE 25A/40A**
- Status LEDs
- PROFILE SELECTION WIRES**
Attached to BCDC Wiring Loom. Default profile set as Standard Lithium (LiFePO₄) for Scout 25/40 models.
- VEHICLE IGNITION INPUT WIRE**
Attached to BCDC Wiring Loom.
- SMART BATTERY MONITOR**
- GND Terminal
- Control Button
- Status LED
- B NEG Terminal
- B POS and RBUS Sockets
- M10 × 20 mm TERMINAL BOLT**
Long Bolt for the Battery Monitor.
- ANDERSON™ SB50 CONNECTORS**
- Solar Input
- Vehicle Input
- 50 A Output
- BATTERY SENSE LEAD**
- CABLE TIES × 2**
- DRAWSTRING BAG**
- MOUNTING TEMPLATE**
- RBUS (RJ45) CABLE**
For expanding your system.

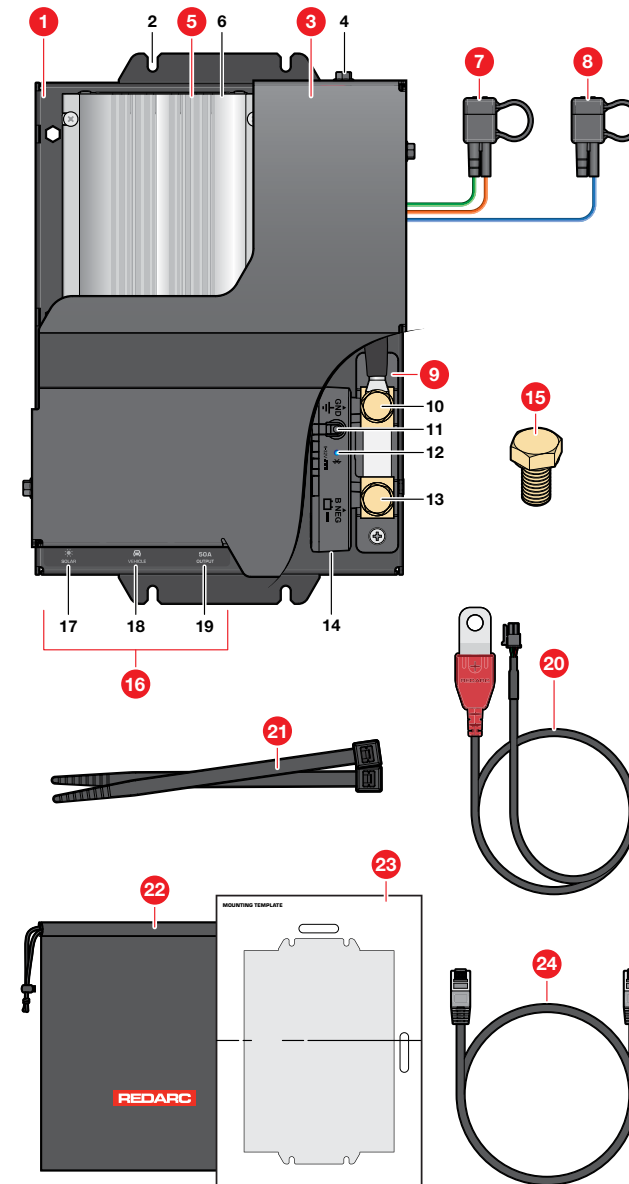

SYSTEM LAYOUT

There are a range of REDARC battery, solar and wiring accessories available for the Scout 25/40 to provide an easy and reliable system setup. To view the complete range, visit redarcelectronics.com

