



VOLKSWAGEN AMAROK 2H

2009 - 2022 (MY22)

TOWING MIRRORS INSTALLATION GUIDE

VERSION 2.2

Towing Mirrors

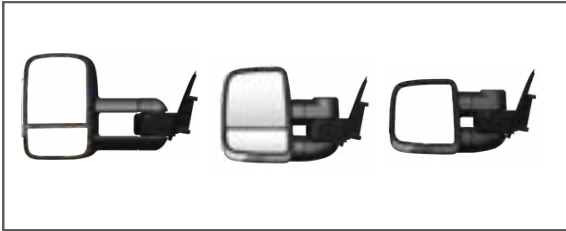

Power Boards



Rock Tamers



Tyre Spider



Easy Slides

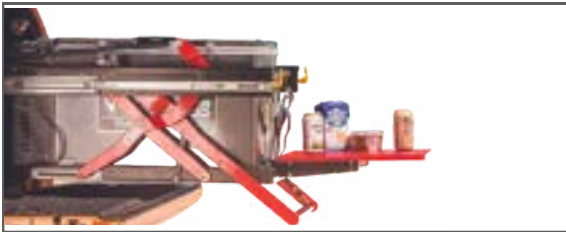

Power Slides



Expanda Slides



Fridge Cage



Pantry



Cutlery Set



Clip on Trays

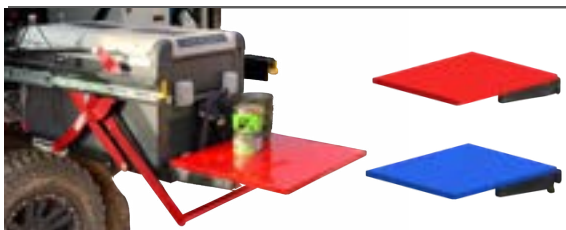

Cable Saver

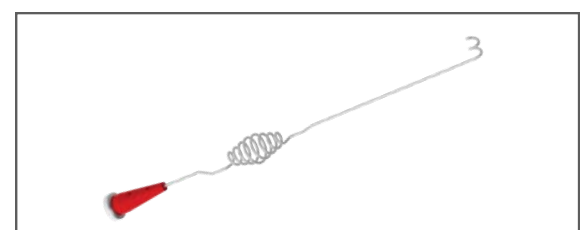

Thank you for choosing Clearview Accessories®

When it comes to road safety, having full visibility of your vehicle and your caravan, trailer or horse float is paramount. Clearview Towing Mirrors extend your field of vision when towing, changing lanes or reversing, to help see you to your destination safely. From Cape York's Telegraph Track to the Gibb River Road, Clearview Towing Mirrors are purpose-built tough for Australian conditions!

Clearview Accessories began in 2006, as a family run business owned by entrepreneur Mike Cowan and his son-in-law Jay Praag. In the years that followed, Mike and Jay turned their small family business with three full-time employees, into one of Australia's most respected 4WD and Touring Brands.



With a strong passion for the automotive industry, quality design and discipline in professional workmanship, our trust is built within our values of creating high quality ADR compliant designs.

From humble beginnings, Clearview Accessories has grown and today manufactures a range of unique, quality products for your next off-road adventure!

Contact us:

Clearview Accessories,
3 Frog Court, Craigieburn VIC 3064
Phone: (03) 8351 9933
Email: info@clearviewaccessories.com.au
Website: clearviewaccessories.com.au

Find us on social media

-  facebook.com/clearviewaccessories
-  instagram.com/clearviewaccessories
-  youtube.com/clearviewaccessories

Due to Clearview's Continuous Improvement Program, information may change without notice. Clearview takes no responsibility for the result of incorrect use of these installation instructions.

Our range	2
Introduction	3
Getting started	5
Before you start	6
Maintaining your mirrors	7
Mirror dimensions	8
Fitting instruction	10-14
FAQS	15
Troubleshooting	16-17
Warranty	18-19

Clearview mirrors are direct replacement mirrors that mount securely in the same position as your original mirrors.

What's in the box



- 1 x Left hand side mirror & base
- 1 x Right hand side mirror & base
- 1 x Installation instruction
- 1 x Pack of clips
- 1 x GPS and blue Plug

If anything is missing, or damaged, please do not install your new mirrors and contact us on 03 8351 9933 or via: info@clearviewaccessories.com.au

Tools required:

- 'S'-hook
- 1/4 drive ratchet with a 10mm socket or 10mm spanner
- Soft plastic pry-bar (Trim remover)
- Phillips head screwdriver
- Flat screwdriver



Whilst our mirrors can be installed by one person, the process is quicker and easier when an additional person is available to hold the mirror into position.



CAUTION



WARNING

- Read through the fitting instructions before installation of Clearview Accessories.
- Always install the accessory following the fitting instructions. Failure to do so may cause damage to the vehicle or the accessory and will void your warranty.
- Ensure all packaging materials are recycled and/or disposed of in accordance with local regulations.
- It is always recommended that this accessory is fitted by a qualified technician.
- Safely store and protect any removed vehicle components.
- Ensure all bare metal surfaces are protected using Automotive Bare Metal Primer and touch-up paint.
- Remove all metal swarf and dust from all vehicle surfaces if the surface is used for accessory installation.
- Your vehicle may be fitted with the Active Park Assist feature. You should only use this feature with your Towing Mirrors in the fully retracted, driving position.



POWER FOLD

WARNING

DO NOT UNFOLD MANUALLY

If your mirror is equipped with Power Fold. In some cases, the mirror head may be loose before installation as the mirror head needs to be electrically folded and unfolded for a minimum of cycles on its first use to synchronise.

Please refrain from folding the mirror MANUALLY as it can reduce the life span of the product.

- **NB:** This mirror is designed to be manually folded upon impact as a safety feature.

COURTESY/PUDDLE LIGHT

Please understand that every car and every model is different and that some vehicles have different wiring options than other vehicles. We do not know the exact wiring configuration of your vehicle.

If you require the use of the courtesy/puddle light function you will require the assistance of an Auto Electrician.

- Clearview Accessories does NOT provide this service unless it's a standard function on the vehicle.

NB: Where there is an electrical modification of the vehicle, a suitably licenced person should undertake the work.

- IF HARD WIRING: **ORANGE WIRE: NEGATIVE (-) | GREY WIRE: POSITIVE (+)**

Maintaining Powder Coated Surfaces

Whilst powder coating is a lot more durable, and longer lasting than paint, it can still be affected by dust, dirt, salt water and constant exposure to the weather. For this reason, no protective powder coating is completely maintenance-free.

With the right maintenance, you can increase the life of the finish of your powder coated surfaces:

- Harsh chemicals and solvents can damage powder coating. Once damaged, the surface is a lot more vulnerable to fading and failure.
- We recommend regularly inspecting your powder coat and wiping any dust off with a soft cloth. Clean, good quality micro-fiber cloths are recommended.
- We recommend regular washing with highly diluted mild soap and water. Use a soft towel to gently clean. Rinse and dry with another soft towel.
- If your powder coat is losing its shine, you can apply a thin layer of high-grade non-abrasive car wax after it's been cleaned. Wipe all the wax off once its dried and the powder coat should look like new again! Use a car wax brand that contains a UV blocker or UV inhibitors. Do not use compound-type waxes as they contain abrasives that can harm the powder coating.

It's important in coastal areas to regularly clean any powder coated surfaces as salt will stick to the coating, dulling its appearance. This can leave your powder coated surface looking chalky.

We don't recommend paint touch ups to cover imperfections as paint won't adhere to powder coated surfaces. A local professional can quote to repair the powder coating.

How do I maintain my Powerfold mirrors?

Under normal Powerfold operation, there shouldn't be any maintenance required. However, if it is regularly used off-road, then the mirrors may need to be maintained every 12 months. This maintenance involves pulling the mirror into the fully extended position and applying dry lubricant on the arms.

Maintaining your Chrome Mirrors

The chrome finish used on our mirror heads is a chrome plated plastic, which provides the appearance and feel of real chrome, in a more lightweight and cost-effective material.

Weather conditions, how often they are washed and how close to the ocean you live, all play a role in the longevity of the chrome finish.

- Automatic car washes that use bristle brushes or acidic preparations can damage your chrome
- Salt and de-icers will surface pit chrome and extra care will be required with more frequent washes to remove residue.
- We recommend washing them weekly with mild soap and water, steering clear of ammonia-based or acid solutions.
- Clean, good quality micro-fiber cloths are recommended to wipe down the chrome surface and prevent water stains from forming
- An occasional polish with a non-abrasive chrome polish will help bring your chrome back to its original shine!

If chrome isn't properly maintained, it can develop pitting from corrosion or lose its attractive shine. We recommend Autosol Metal Polish and Autosol Metal Life Saver

Clearview Original

Non-Extended Standard Driving Position

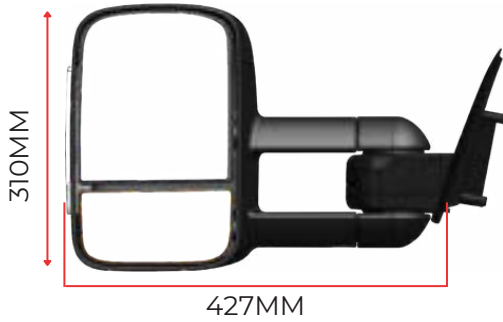

Fully Extended Towing Position

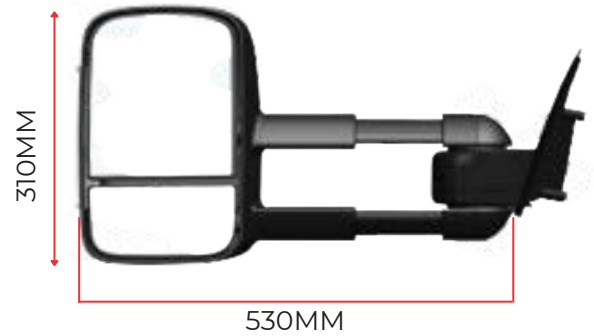

Clearview Next Gen

Non-Extended Standard Driving Position



Extended Towing Position

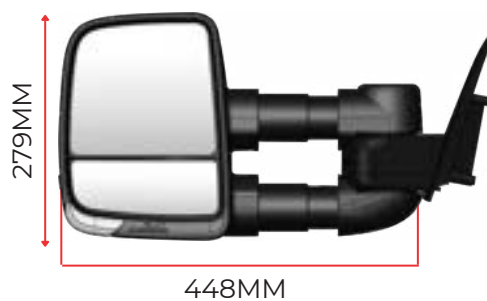

Fully Extended Towing Position

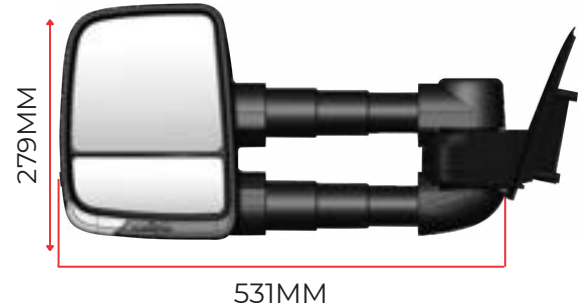

Clearview Compact

Non-Extended Standard Driving Position



Extended Towing Position



Fully Extended Towing Position

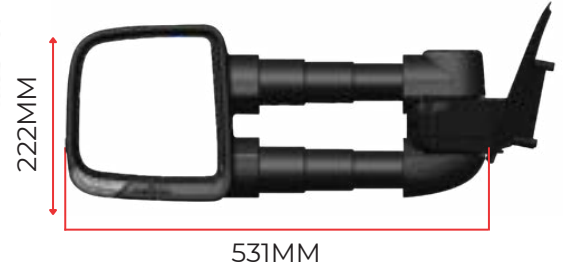



Your adventure awaits...
Let's Begin!

SCAN TO VIEW
OUR INSTALLATION
INSTRUCTION

Volkswagen Amarok
2009 - Current



Step 1

Prepare vehicle:

Place transmission into park position with handbrake on.

Turn ignition on and lower front door glass/windows.

Turn ignition off.

Ensure that your two front windows are down.

Locate your panel removing tool and remove the door latch panel, starting from the middle.



Step 2

Remove door trim:

Remove the 2 screws that sit flush against the door latch.



Step 3

Remove door trim:



Now, begin to remove the door trim and quarter panel. Use a wedging technique between the interior and exterior to remove the trim. We have included replacement clips in your Clearview box in case some of your original clips break during this process.

Step 4

Remove door trim:



Once the door trim has been removed, ensure that the trim does not touch the ground by using a hook to hang it off your door. Unplug the cables from its connector followed by disconnecting the radio antenna, and the dark blue GPS plug.

Step 5

Remove the OEM Mirror:



Locate your vehicle's standard mirror's 3x nuts and remove them. Ensure that you have a firm grip of the mirror while removing the nuts.



HANDY TIP: Keep your original OEM mirrors as back up should something happen to one of your Clearview Mirrors, necessitating the need to return it to us for repairs.

Step 6

Installing the Clearview Towing Mirrors:

Locate your new Clearview Towing Mirrors and remove the 3x nuts. Align the mirrors to the quarter panel, feeding any cables from the mirror through at the same time, and begin to screw the nuts back into the Clearview Towing Mirrors. Ensure that you are not over tightening.

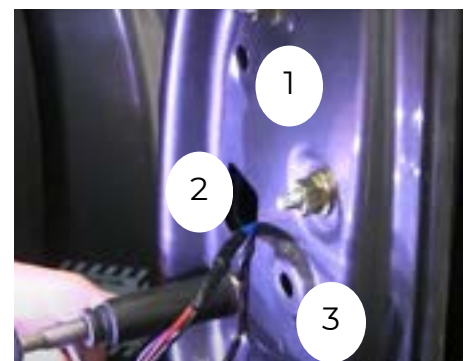

Step 7

Installing the Clearview Towing Mirrors:

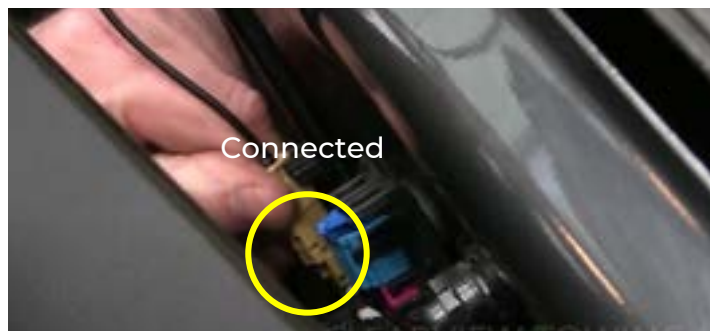

Once the mirror is secure, plug the cables from your mirror back into the connector. Followed by your radio antenna.

Step 8

Please proceed with the next step if you have purchased your Towing Mirror with the GPS feature, if not skip this step.



Locate the provided Clearview GPS which can be found in the bottom of the packaging, then remove the blue plug cover, and the GPS.

Apply the blue plug cover over the end cable of the Clearview GPS. Ensure the cover is fully secured, you can use a pair of pliers, to ensure it clips into place.

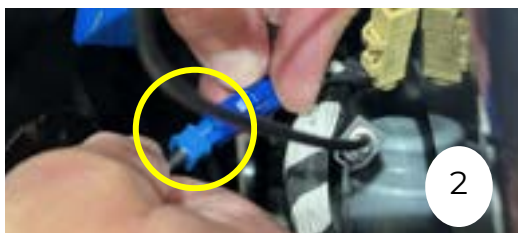

- With the Clearview GPS Cable, connect your Clearview Blue Wiring, to the blue wiring connector. Ensuring it's all the way home. (As per image 2.)
- Once the GPS Wiring is connected, remove the adhesive cover, to release the sticky side. (As per image 3.)
- Now that you have removed the cover, you can secure it to your door frame. Locate a cavity within the frame, which offers a flat surface. Ensure the Area is clean, and then mount the GPS Monitor to the door panel.
- Ensure that the GPS Monitor is secure.

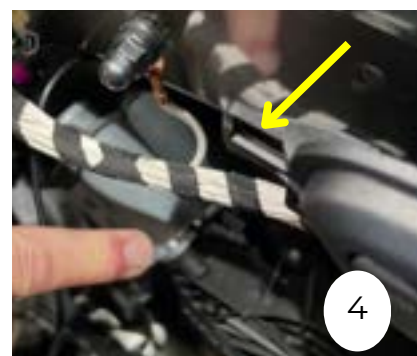

Step 9

Test the Mirrors:

It is now time to begin testing that your Clearview Mirrors are operating correctly. Test all your mirror functionality to ensure they run the correct way; Indicate left, Indicate right, electrically adjust your mirror view etc. If your mirror functions correctly, it is now time to re-affix your door panel into position. If your mirror is not functioning properly, see our troubleshooting on page 16-17 or follow the instructions again just in case a step has been missed.



Step 10

Re-assemble the door trim:

Remove any clips that may be broken from the door trim removal, and replace them with the new ones supplied.



Step 11

Re-assemble the door trim:



Once all broken clips have been replaced, you may now align the door trim back on. Ensure you have no wires or cables trapped.

Step 12

Re-assemble the door trim:



Finish off by aligning your quarter panel and putting all screws back into position.

Congratulations! You have now fully installed your new Clearview Towing Mirrors and are ready for your next adventure!

Can I install Clearview mirrors myself?

Yes! Depending on the complexity of the installation, Clearview mirrors are extremely easy to install and mount to the vehicle's original OEM mirror mounts. Depending on the vehicle's current mirror options, Clearview mirrors include plug and play wiring looms. Instructional videos are also available on our [website](http://clearviewaccessories.com.au) (clearviewaccessories.com.au) in the "HOW TO" section. Clearview recommends that any installation requiring hard wiring be done by a licensed auto electrician.

What is the fitting time?

Depending on the complexity of the installation, a dealer should be able to install the mirrors in approximately 15 minutes per side of the vehicle. Installation requiring special fitting and/or hard wiring will require longer fitting times (eg: Camera and electric wiring kits). Note: The 70 Series mirrors with electrics are more complex and will take more time than a 'normal' vehicle fitting. Please contact Clearview mirrors if you have any questions about fitting or wiring.

Are the telescopic arms electric?

No. The telescopic arms are extended manually. Clearview Mirrors will only fold against the vehicle electronically provided we make that model in Power Fold.

Can I retrofit the original mirror base to the Next Gen or Compact mirrors?

No. The cost of converting the mirrors to suit the new models is not worth it. We recommend either selling your Original mirrors privately or through the "Pre-Loved" section (Within the "Shop" menu category) of our website and purchasing the new Next Gen or Compact mirrors brand new.

Can I add an indicator later if I didn't order the mirrors with an indicator?

Yes, you can. But it comes at a greater expense than if you were to order the mirrors with indicators. Installation to the mirror head will require longer time and more parts to dismantle.

Are spare parts available?

Yes. We have a list of spare parts for all our mirrors on our website. Our dealers also have a list of all our spare parts.. If you cannot find the parts that you require, please contact us or any of our dealers to assist you with your inquiry

How do I maintain my mirrors?

SCAN THE QR CODE
AND VIEW OUR VIDEO
DEMONSTRATING
how to lubricate
the mirror arms.



We recommend using WD-40 Dry
Lubricate.

How do I maintain my Powerfold mirrors?

Under normal Powerfold operation, there shouldn't be any maintenance required. However, if it is regularly used off-road, then the mirrors may need to be maintained every 12 months. This maintenance involves pulling the mirror into the fully extended position and applying dry lubricant on the arms.

I have just installed my new Powerfold mirrors and the mirror heads appear to be loose/floppy?

After the mirrors are installed, they need to be cycled a few times. This will allow all the internal mechanisms to set and find the proper positions. If the mirror head is still loose/floppy after they're cycled, please contact Clearview Technical Support.

I have installed my Powerfold Mirrors and have noticed that the Passenger's side mirror is closer to the vehicle compared to the Driver's side; Is this normal?

This is completely normal. In most vehicles, the mirror housings are angled differently between the driver and passenger side. This is because when you sit in the car, you are off centre, so generally the passenger side mirrors are closer to the vehicle body to allow you to have the same field of vision in the mirror.

One of my Powerfold Mirrors folds/opens quicker than the other one; Is this normal?

Generally, the passenger mirror will fold/open quicker, as it is closer to the vehicle body and therefore travels a shorter distance compared to the driver's side mirror. See previous question in regards to why the mirrors are angled differently.

My mirrors have been knocked out of Driving Position; how do I fix it?

Press the powerfold switch once. This should initiate the powerfolding motors and the mirrors should start folding inwards. Wait until the mirrors are fully folded in and have stopped moving, then press the powerfold switch again. This should now bring your mirrors back out to normal driving position. Check and see if the mirrors are locked into position firmly. If the mirror is not returning to the normal position, please contact Clearview Technical Support.

***Note:** The Powerfold mirrors can fold manually, however the manual fold mechanism is only designed as a safety feature. Through the lifespan of the product, manual folding will occur, such as people walking into them or accidentally bumping them. The internal mechanisms are designed to withstand this accidental manual folding during normal usage. It is not recommended for the mirrors to be manually folded constantly, as it will prematurely wear out the internal folding mechanisms and reduce the lifespan of the product.*

My mirror was knocked out of driving position. When I cycled them, there is a clicking sound and the mirror appears to have "jumped"; Are my mirrors damaged?

When the Powerfold mirror is being cycled to find its original driving position, it will "jump" back into position and make an audible click sound when mechanisms realign. Once the mirrors have found the original position and have been cycled, check for looseness and mirror movement. If they feel firm, then the mirrors have not been damaged. If they still feel loose, please contact Clearview Technical Support.

Why don't my mirrors fold all the way in/out when I press the switch?

The circuit breaker inside the mirror activates when the electrical current increases due to resistance. If the mirror stops before it reaches the folded in/out position, that means something is adding resistance while the mirrors are folding, hence activating the circuit breaker before it has reached the desired position. Please contact Clearview Technical Support.

Clearview Towing Mirrors are full replacement towing mirrors designed and manufactured to the highest quality standards to replace your vehicle's standard side mirrors. We stand behind our Next Gen and Compact Towing Mirrors with a 3-year Manufacturer's Warranty and 7-year Parts Warranty. We stand behind our Original Towing Mirrors with a 12-Month Manufacturer's Warranty and 3-year Parts Warranty. Clearview Accessories warranty applies to the original purchaser only.

Please ensure that your receipt is kept in a safe place. A receipt will be required to make a warranty claim on any Clearview product. If we determine that a Clearview Towing Mirror is defective in materials or workmanship during the Warranty, we will either repair or replace the product. Repair or replacement is solely at the discretion of Clearview Accessories.

Please ensure that you fit the Clearview products in accordance with the product information provided and all relevant vehicle safety and compliance laws; and use the Clearview product for the purpose for which it was originally designed. This warranty does not apply to failure or damage caused by incorrect or faulty fitment, accidental or intentional damage, alteration, acts of nature, vandalism, collision, road hazards or adverse conditions, misuse, abuse or neglect of the Clearview product, including improper repair or maintenance or failing to repair and maintain the product, failure of other products, operation of the product outside of its environmental or technical specifications, or repair or modification carried out by anyone other than Clearview Accessories. No charges will be accepted for external labour or materials without the prior advice or clearance from Clearview claims team. Clearview Accessories warranty does not cover any scratches or chips.

Clearview Towing Mirrors are designed to be vehicle specific. When purchasing Clearview Towing Mirrors, carefully select your product according to ADR compliance laws and vehicle specifications. Clearview Towing Mirrors are not designed to be modified for convenient use on alternative vehicles. Alteration, modification, or manipulation of our products will void all warranty with Clearview Accessories.

All claims under this warranty should be lodged through our website warranty section <https://www.clearviewaccessories.com.au/about/warranty/> with the detail of the fault, proof of purchase, proof of identification and vehicle fitment details where relevant. If your claim is accepted for defects in material or workmanship Clearview will, at its discretion, offer to repair, replace parts, or return and refund.

Our goods come with guarantees that cannot be excluded under the Australian Consumer Law. You are entitled to a replacement or refund for a major failure and for compensation for any other reasonably foreseeable loss or damage. You are also entitled to have the goods repaired or replaced if the goods fail to be of acceptable quality and the failure does not amount to a major failure. In the event of a minor failure, the company reserves the right to choose to repair or replace the product.

Clearview Towing Mirrors, ABN: 59 140 145 393, 3 Frog Court, Craigieburn VIC 3064
Ph: (03) 8351 9933 Email: info@clearviewaccessories.com.au



CLEARVIEW
ACCESSORIES

3 Frog Court, Craigieburn
VIC 3064, Australia
(03) 8351 9933

info@clearviewaccessories.com.au

clearviewaccessories.com.au